

STR3

Hardware Manual



Contents

1	Introduction.....	4
1.1	Features	4
1.2	Block Diagram.....	4
1.3	Safety Instructions.....	5
2	Getting Started	6
2.1	Mounting the Hardware.....	6
2.2	Choosing a Power Supply.....	6
2.2.1	Supply Voltage	6
2.2.2	Supply Current.....	6
2.2.3	Multiple Drives Sharing One Power Supply	7
3	Connections.....	8
3.1	Connector Signals.....	8
3.1.1	Connect Main Power Supply	9
3.1.2	Connector Pin Diagram.....	10
3.1.3	STEP and DIR Inputs.....	10
3.1.4	EN Input	11
3.2	Switch Selecting.....	12
3.2.1	Running Current	12
3.2.2	Idle Current.....	13
3.2.3	MicroStep Setting.....	13
3.2.4	Self Test	14
3.2.5	Step Smoothing Filter	14
3.2.6	Control Mode.....	14
3.2.7	Step Noise Filter	14
4	Motor Selection.....	15
5	Troubleshooting	16
6	Reference Materials.....	17
6.1	Mechanical Outline	17
6.2	Technical Specifications	18
6.3	Torque Curves.....	19
6.4	Motor Heating	21
6.5	Mating Connectors.....	23

(This page intentionally left blank)

1 Introduction

Thank you for selecting the Applied Motion Products STR3 step motor drive. We hope our commitment to performance, quality and economy will make a successful motion control project. The STR3 Step motor drive is a cost-effective, high performance drive. The design is based on advanced digital current control technology, and features high torque, low noise and low vibration. Running current, microstep resolution, and other parameters are switch selectable so software configuration is not required.

1.1 Features

- Power Supply - Operates from a 12 to 48 volt DC power supply
- Inputs - 3 optically isolated digital inputs, 5 to 24 volts
- Speed Range - up to 3000 rpm
- Current Control - 3 piano switch setting running current, 3 Amps peak maximum
- Idle Current - Switch selectable for reduction to 50% or 90% of running current 1 second after the motor stops
- Self Test - Performs a 2 rev, 1 rps, CW/CCW move test, switch selectable: ON or OFF
- Control Mode - Step & Direction mode, CW/CCW mode
- Microstep Resolution - 4 piano Switch selectable, 16 settings: 200, 400, 800, 1600, 3200, 6400, 12800, 25600, 1000, 2000, 4000, 5000, 6000, 8000, 10000, 20000 steps/rev

1.2 Block Diagram

STR3
Block Diagram

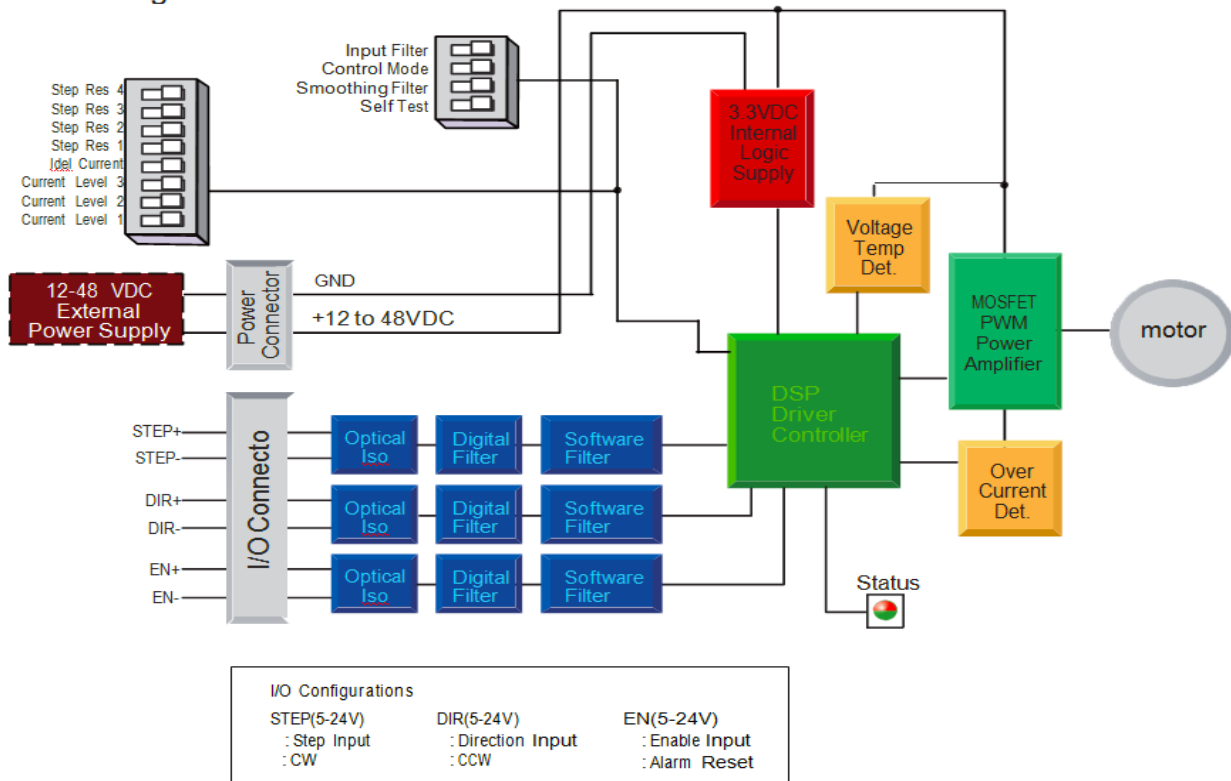

1.3 Safety Instructions

Only qualified personnel should transport, assemble, install, operate, or maintain this equipment. Properly qualified personnel are persons who are familiar with the transport, assembly, installation, operation, and maintenance of motors, and who meet the appropriate qualifications for their jobs.

To minimize the risk of potential safety problems, all applicable local and national codes regulating the installation and operation of equipment should be followed. These codes may vary from area to area and it is the responsibility of the operating personnel to determine which codes should be followed, and to verify that the equipment, installation, and operation are in compliance with the latest revision of these codes.

Equipment damage or serious injury to personnel can result from the failure to follow all applicable codes and standards. Applied Motion Products does not guarantee the products described in this publication are suitable for a particular application, nor do they assume any responsibility for product design, installation, or operation.

- Read all available documentation before assembly and operation. Incorrect handling of the products referenced in this manual can result in injury and damage to persons and machinery. All technical information concerning the installation requirements must be strictly adhered to.
- It is vital to ensure that all system components are connected to earth ground. Electrical safety is impossible without a low-resistance earth connection.
- This product contains electrostatically sensitive components that can be damaged by incorrect handling.
- Follow qualified anti-static procedures before touching the product.
- During operation keep all covers and cabinet doors shut to avoid any hazards that could possibly cause severe damage to the product or personal health.
- During operation the product may have components that are live or have hot surfaces.
- Never plug in or unplug the step motor drive while the system is live. The possibility of electric arcing can cause damage.

Be alert to the potential for personal injury. Follow all recommended precautions and safe operating practices. Safety notices in this manual provide important information. Read and be familiar with these instructions before attempting installation, operation, or maintenance.

The purpose of this section is to alert users to the possible safety hazards associated with this equipment and the precautions necessary to reduce the risk of personal injury and damage to equipment. Failure to observe these precautions could result in serious bodily injury, damage to the equipment, or operational difficulty.

2 Getting Started

To use the STR3 step motor drive, the following items are needed:

- A 12 - 48 volt DC power supply, see the section below entitled “Choosing a Power Supply” for help in choosing the right one
- Step & Direction signals
- A small flat blade screwdriver for configuring the switches (included)

2.1 Mounting the Hardware

As with any step motor, the STR3 must be mounted so as to provide maximum heat sinking and airflow. Keep enough space around the Step motor drive to allow for airflow.



- Never use the drive where there is no airflow or where other devices cause the surrounding air to be more than 40°C (104°F).
- Never put the drive where it can get wet.
- Never use the drive where metal or other electrically conductive particles can infiltrate the drive.
- Always provide airflow around the drive.

2.2 Choosing a Power Supply

When choosing a power supply, there are many things to consider. If you are manufacturing equipment that will be sold to others, you probably want a supply with all the safety agency approvals. If size and weight are an issue get a switching supply. Also, you must decide what size of power supply (in terms of voltage and current) is needed for your application.

Applied Motion offers three power supplies that are excellent matches for the STR3 drive: PS50A24 (24V, 2.1A), PS150A24 (24V, 6.3A) and PS320A48 (48V, 6.7A).

2.2.1 Supply Voltage

Your motor can provide more torque at higher speeds if a higher power supply voltage is used. Please consult the speed-torque curves later in this manual for guidance.

If you choose an unregulated power supply, make sure the no load voltage of the supply does not exceed the drive's maximum input voltage specification.

2.2.2 Supply Current

The maximum supply current you could ever need is two times the motor current. However, you will generally need a lot less than that, depending on the motor type, voltage, speed and load conditions. That's because the STR uses a switching amplifier, converting a high voltage and low current into lower voltage and higher current. The more the power supply voltage exceeds the motor voltage, the less current you'll need from the power supply. A motor running from a 48 volt supply can be expected to draw only half the supply current that it would with a 24 volt supply.

We recommend the following selection procedure:

1. If you plan to use only a few drives, get a power supply with at least twice “per phase” current rating of the step motor. Example: for a motor that’s rated for 2 A/phase use a 4A power supply.
2. If you are designing for mass production and must minimize cost, get one power supply with more than twice the rated current of the motor. Install the motor in the application and monitor the current coming out of the power supply and into the drive at various motor loads. This will tell you how much current you really need so you can design in a lower cost power supply.

The table below list the maximum current required for each motor at several common power supply voltages. Please consider this information when choosing a power supply.

Motor	Connection	Current Setting (A)	Max Power Supply Current (A)		
			12VDC	24VDC	48VDC
HT08-020	4 leads	0.40	0.95A	0.95A	N/A
HT08-021	4 leads	0.40	0.95A	0.95A	N/A
HT11-012	4 leads	1.20	0.6A	0.6A	N/A
HT11-013	4 leads	1.20	0.95A	0.95A	N/A
HT17-268	parallel	1.60	1.0A	1.0A	1.0A
HT17-271	parallel	2.00	1.3A	1.3A	1.3A
HT17-275	parallel	2.00	1.32A	1.32A	1.32A
HT23-595	series	2.40	1.36A	1.36A	1.36A
HT23-598	series	2.40	1.56A	1.56A	1.56A
HT23-601	series	2.40	1.4A	1.4A	1.4A
HT23-394	parallel	3.0	N/A	2.0A	3A
HT24-100	4 leads	3.0	N/A	1.2A	1.75A

2.2.3 Multiple Drives Sharing One Power Supply

You can use one supply to power multiple drives. The worst case condition occurs when all the drives are running simultaneously. In this case, just add up the power supply currents for each to determine the total power supply current requirement.

3 Connections

3.1 Connector Signals

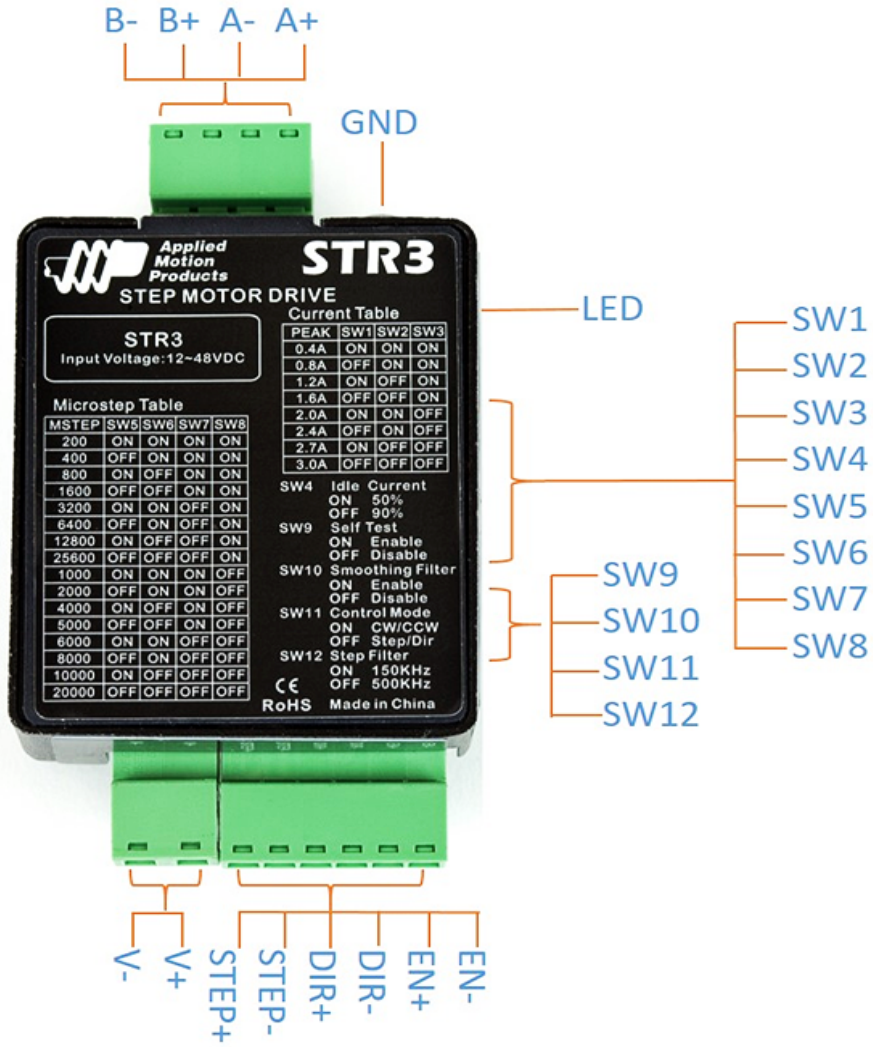

3.1.1 Connect Main Power Supply

If the power supply does not have a fuse on the output or some kind of short circuit current limiting device a fast acting fuse is required. A 3 Amp fast acting fuse should be installed in line with the “+” power supply lead.

Connect the power supply “+” terminal to the drive “V+” terminal.
Connect the power supply “-” terminal to the drive “V-” terminal.



Be careful not to reverse the “+” and “-” wires. Reversing the connection may open the internal fuse on the drive and void the warranty.

If a regulated power supply is being used, there may be a problem with regeneration. When a load decelerates rapidly from a high speed, some of the kinetic energy of the load is transferred back to the power supply, possibly tripping the over-voltage protection of a regulated power supply, causing it to shut down. This problem can be solved with the use of A Applied Motion Products RC880 Regeneration Clamp. It is recommended that an RC880 initially be installed in an application. If the “regen” LED on the RC880 never flashes, the clamp is not necessary.



3.1.2 Connector Pin Diagram

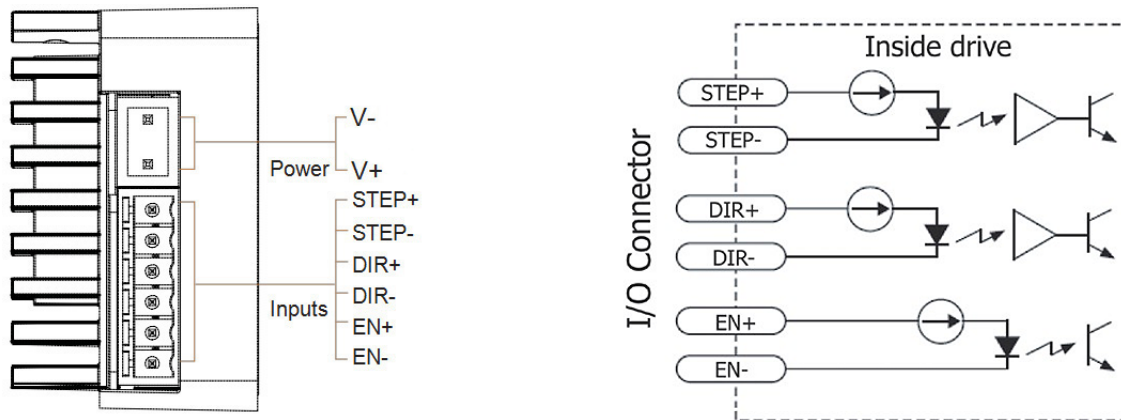

3.1.3 STEP and DIR Inputs

The STR3 step motor drive has two high speed optically isolated inputs called STEP and DIR. They accept 5 to 24 volt single-ended or differential signals, up to 500KHz. The maximum voltage that can be applied to the input is 28V.

The motor executes one step when the STEP input closes.

The direction of rotation is controlled by the DIR input state. A closed input (logic “0”) will result in clockwise rotation, and an open input (logic “1”) will result in counterclockwise rotation.

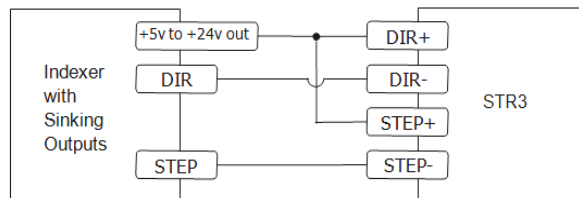

Connecting to Indexer with Sinking Outputs

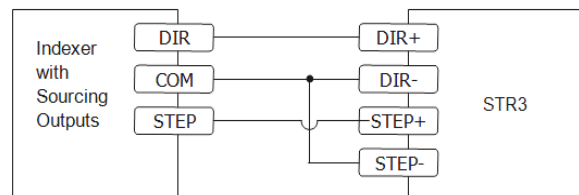

Connecting to Indexer with Sourcing Outputs

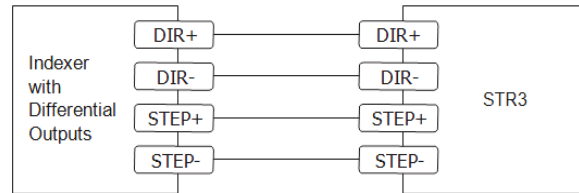

Connecting to Indexer with Differential Outputs
Many high-speed indexers have differential outputs

3.1.4 EN Input

The EN input enables or disables the drive Amplifier. It is an optically isolated input that accepts a 5 to 24 volt single-ended or differential signal. The maximum voltage that can be applied to the input is 28V.

When EN input is closed, the drive Amplifier is deactivated. All the MOSFETs will shut down, and the motor is free. When EN input is open, the drive is activated.

When the drive has encountered an error and the fault is removed from system, a falling signal into the EN input will reset the error status and activate the drive Amplifier again.

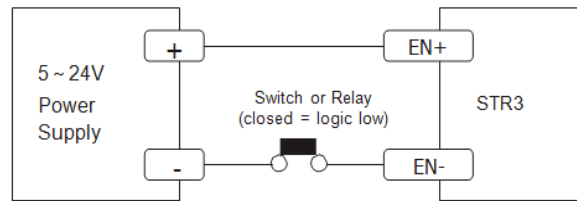

Connecting the Input to a Switch or Relay

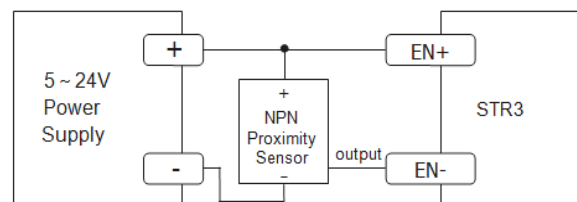

Connecting an NPN type Proximity Sensor to an input
(when prox sensor activates, input goes low)

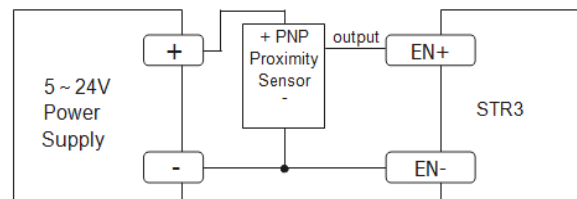

Connecting a PNP type Proximity Sensor to an input
(when prox sensor activates, input goes low)

3.2 Switch Selecting

The EN input enables or disables the drive Amplifier. It is an optically isolated input that accepts a 5 to 24 volt single-ended or differential signal. The maximum voltage that can be applied to the input is

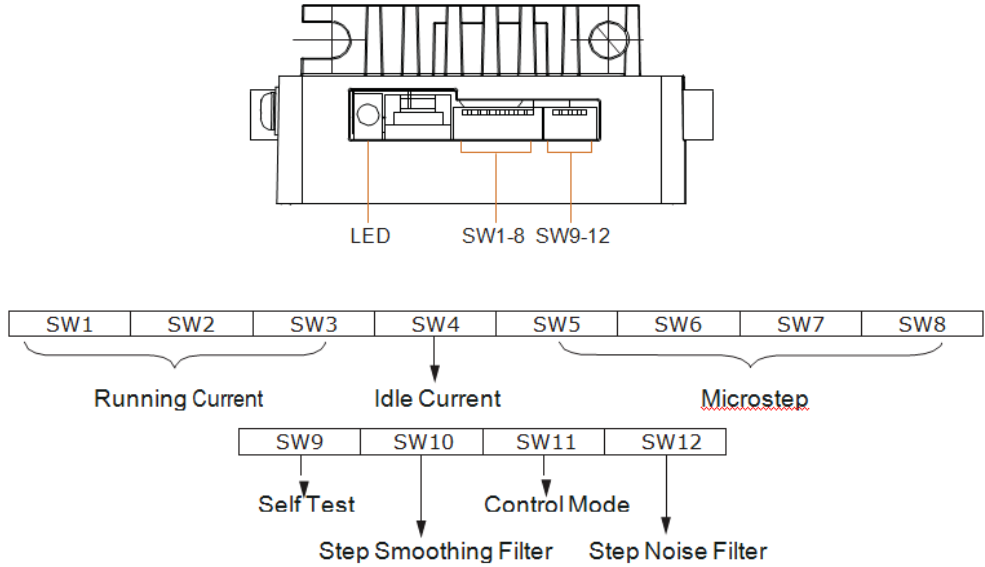

3.2.1 Running Current

The output current of the STR3 step motor drive is set by the SW1, SW2 and SW3 switches and can be changed as necessary. There are 8 settings available according to the ON/OFF combination of the switches.

Current (Amps) (peak of sine)	SW1	SW2	SW3
0.4	ON	ON	ON
0.8	OFF	ON	ON
1.2	ON	OFF	ON
1.6	OFF	OFF	ON
2.0	ON	ON	OFF
2.4	OFF	ON	OFF
2.7	ON	OFF	OFF
3.0	OFF	OFF	OFF

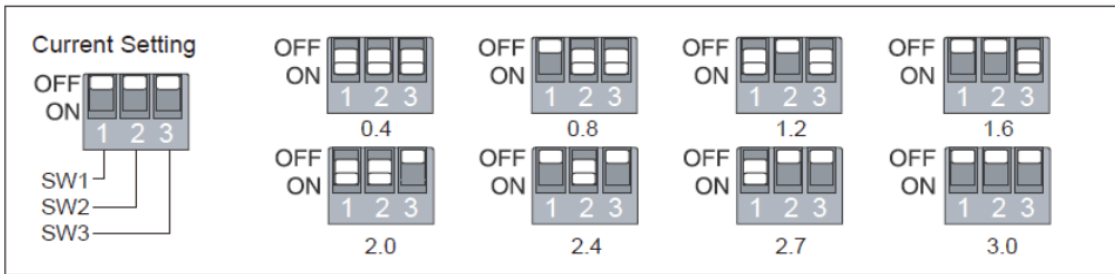

3.2.2 Idle Current

The running current of the STR3 is automatically reduced whenever the motor isn't moving. Setting the SW4 switch to ON maintains 50% of the running current. Setting this switch to OFF maintains 90% of the running current. This 90% setting is useful when a high holding torque is required. To minimize motor and drive heating it is highly recommended that the idle current reduction feature be set to 50% unless the application requires the higher setting.

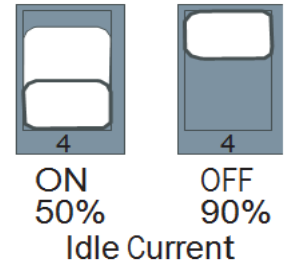

3.2.3 MicroStep Setting

STR3 setting switch SW5, SW6, SW7, SW8. There are 16 settings.

Steps/Rev	SW5	SW6	SW7	SW8
200	ON	ON	ON	ON
400	OFF	ON	ON	ON
800	ON	OFF	ON	ON
1600	OFF	OFF	ON	ON
3200	ON	ON	OFF	ON
6400	OFF	ON	OFF	ON
12800	ON	OFF	OFF	ON
25600	OFF	OFF	OFF	ON
1000	ON	ON	ON	OFF
2000	OFF	ON	ON	OFF
4000	ON	OFF	ON	OFF
5000	OFF	OFF	ON	OFF
6000	ON	ON	OFF	OFF
8000	OFF	ON	OFF	OFF
10000	ON	OFF	OFF	OFF
20000	OFF	OFF	OFF	OFF

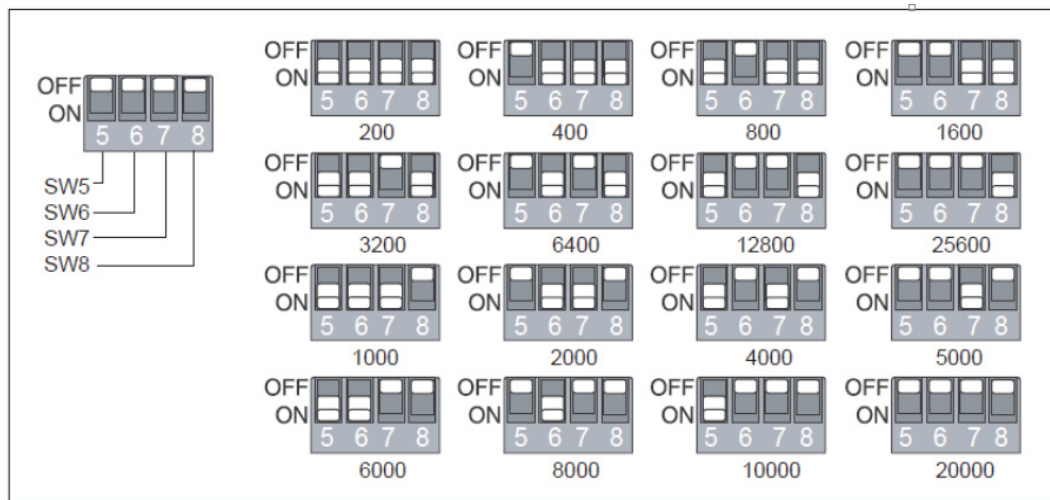

3.2.4 Self Test

A built-in self-test feature is available on the STR3 to check the physical operation of the motor. Setting switch SW9 to ON after the drive is powered up will cause the drive to perform a self test move of 2 revolutions both CW and CCW at 1rps. Setting switch SW9 to OFF disables this feature.

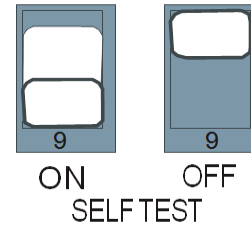

3.2.5 Step Smoothing Filter

Command signal smoothing can soften the effect of immediate changes in velocity and direction, making the motion of the motor less jerky. An added advantage is that it can reduce the wear on mechanical components. SW10 selects this function - ON enables it, OFF disables it.

This function can cause a small delay in following the control signal, and it should be used with that in mind

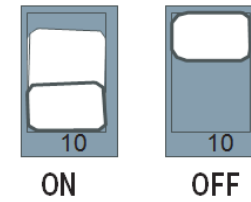

3.2.6 Control Mode

Switch SW11 sets control mode. Switch OFF sets the Step & Dir mode. Switch ON sets the CW/CCW mode

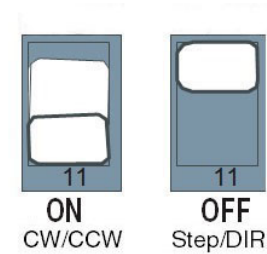

3.2.7 Step Noise Filter

Switch SW12 sets the digital signal filter. The STEP and DIR signal inputs have built-in digital filters and this setting will reduce external noise. If the system works on the low microstep, select the 150 KHz (ON) setting. If the system works on the high microstep, select the 500KHz (OFF) setting



4 Motor Selection

Motor wires setting:

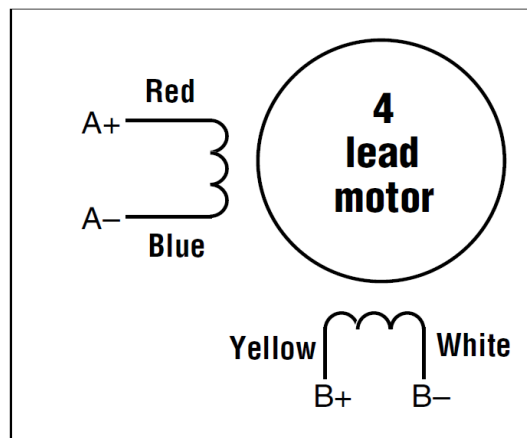
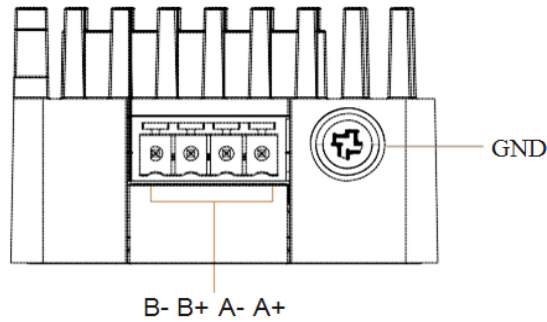

4 Leads

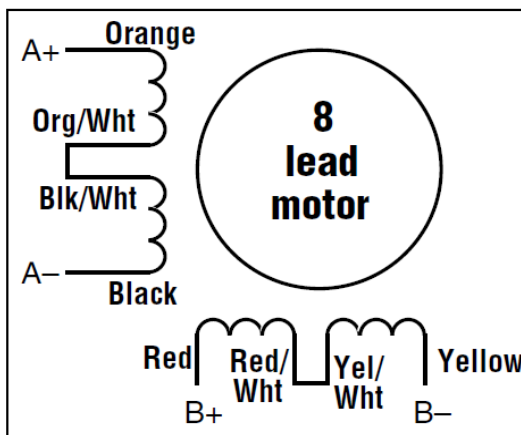

8 Leads Series Connected

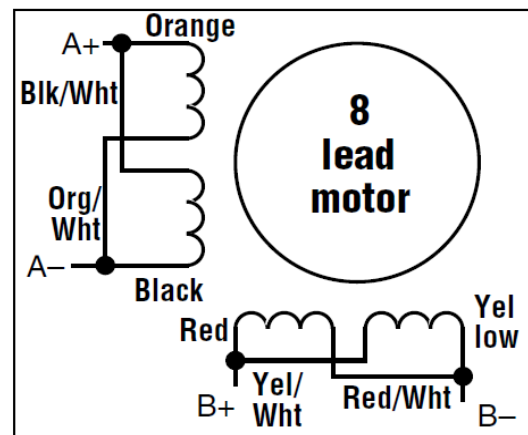









8 Leads Parallel Connected

5 Troubleshooting

LED ERROR CODES

The STR3 has one bicolor (red/green) LED to indicate status and errors. When the motor is enabled, the LED slowly flashes green. When the LED is solid green, the motor is disabled. If the LED flashes red, an error has occurred. Errors are indicated by a c

Code		Error
	Solid	Motor Disabled
	Flashing	Motor Enabled
	3 red, 1 green	Over Temperature
	3 red, 2 green	Bad Internal Voltage
	4 red, 1 green	Power Supply Over Voltage
	4 red, 2 green	Power Supply Under Voltage
	5 red, 1 green	Over Current/Short Circuit
	6 red, 1 green	Open Winding

6 Reference Materials

6.1 Mechanical Outline

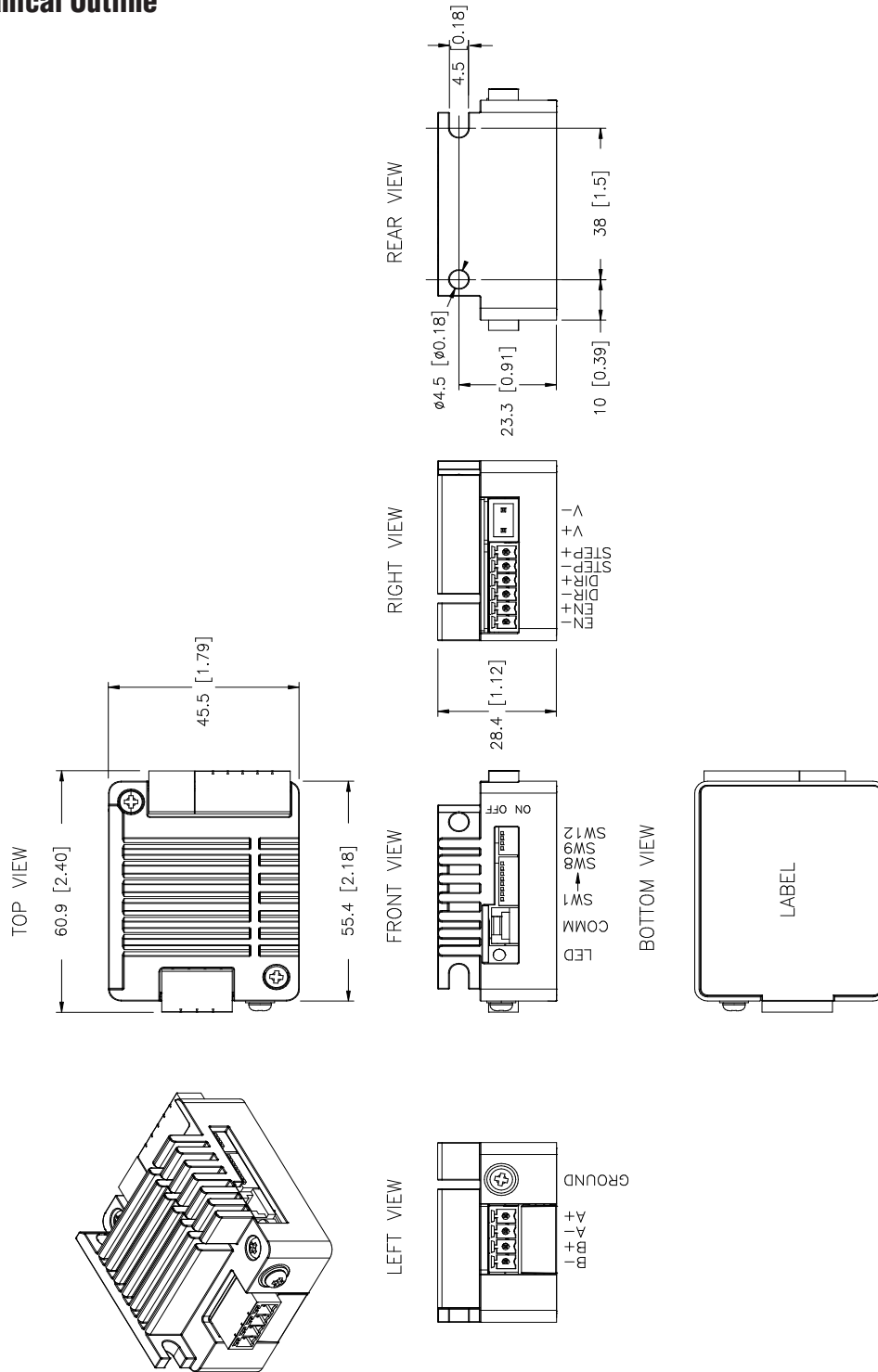

6.2 Technical Specifications

Power Amplifier	
Amplifier Type	Dual H-Bridge, 4 Quadrant
Current Control	4 state PWM at 16 KHz
Power Supply	External 12 - 48 volt power supply required
Input Voltage Range	10 - 53 volts min/max (nominal 12 - 48 volts), voltages outside this range will cause driver faults and/or may damage the drive
Protection	Over-voltage, over-current, under-voltage, over-temp, internal motor shorts (phase-to-phase, phase-to-ground)
Ambient Temperature	0 - 40 °C (32 - 104 °F) when mounted to a suitable heat sink
Humidity	90% non-condensing

Controller	
Current Control	Advanced digital current control provides excellent high speed torque
Speed Range	Speeds up to 3000 rpm
Auto Setup	Measures motor parameters to configure current control and anti-resonance gain settings
Step Input STEP+/-	Inputs: optically isolated, 5 - 24 volts, min. pulse width 250 us., max. pulse frequency 500KHz; motor executes one step when the STEP input closes
Direction Input DIR+/-	Inputs: optically isolated, 5 - 24 volts, min. pulse width 62.5 us., max. pulse frequency 500KHz; direction of rotation is controlled by the DIR input state
Enable Input EN+/-	Inputs: optically isolated, 5 - 24 volts, min. pulse width 500 us., max. pulse frequency 10 KHz; enables or disables the drive Amplifier
Running Current	Switch selectable, 8 settings: 3 Amps peak maximum
Idle Current Reduction	Automatically reduces the current 1 second after the motor stops; switch selectable, 2 settings: 50% or 90% of the running current
Microstep Resolution	Switch selectable, 16 settings: 200, 400, 800, 1600, 3200, 6400, 12800, 25600, 1000, 2000, 4000, 5000, 6000, 8000, 10000, 20000 steps/rev
Self Test	Checks internal and external power supply voltages, 2 rev move both CW and CCW at 1rps, switch selectable, ON or OFF
Modes Of Control	Step & Direction, CW/CCW control

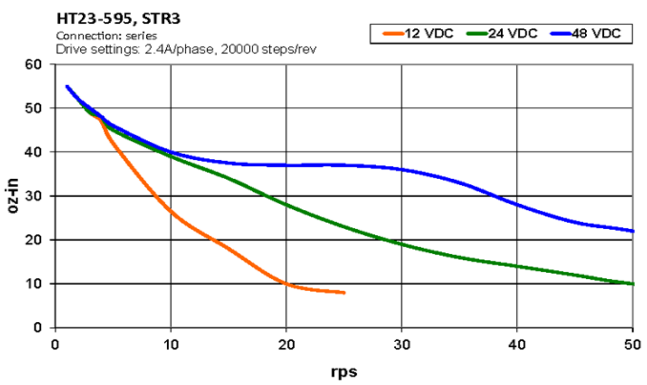
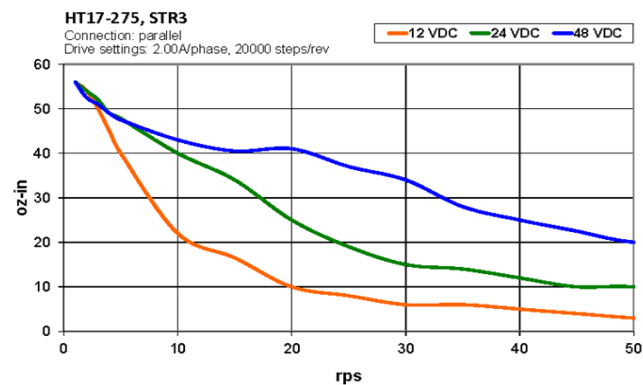
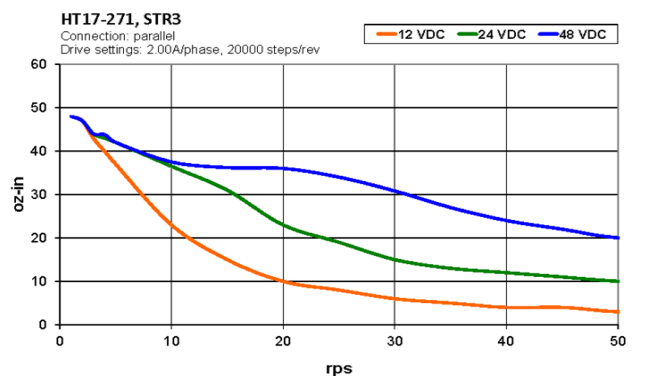
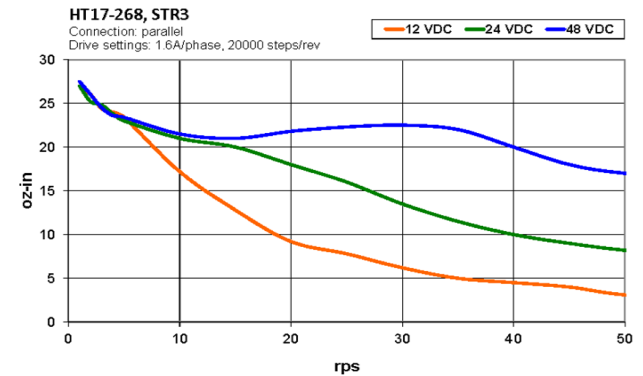
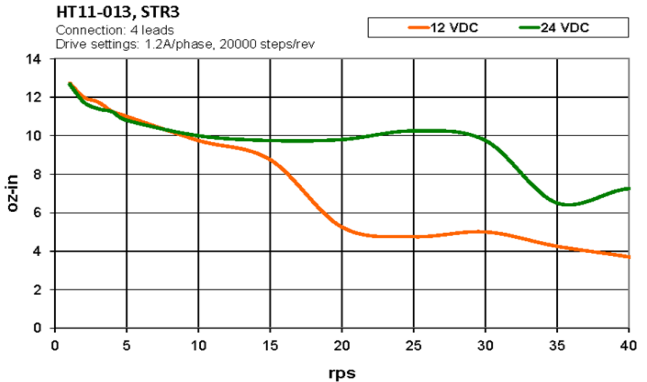
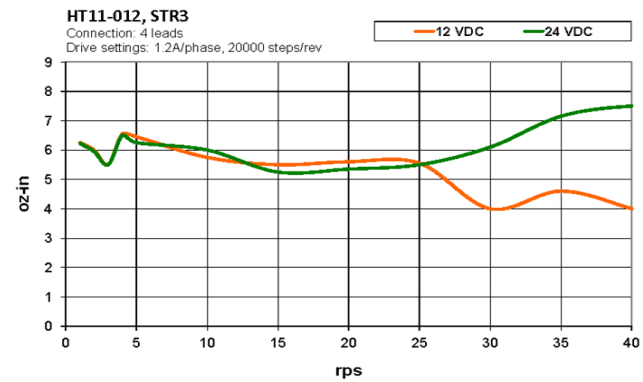
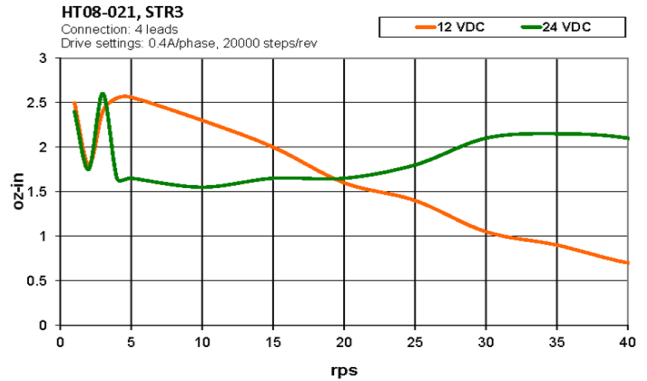
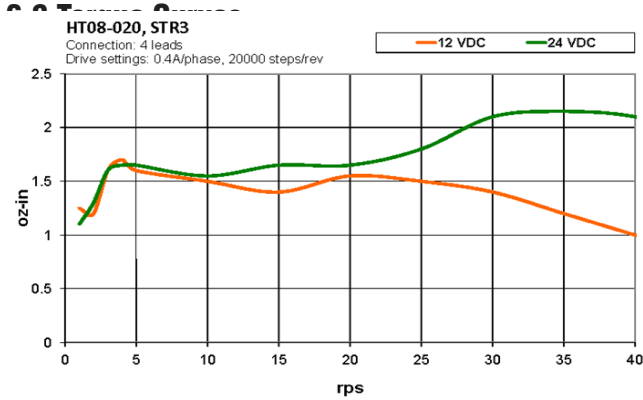

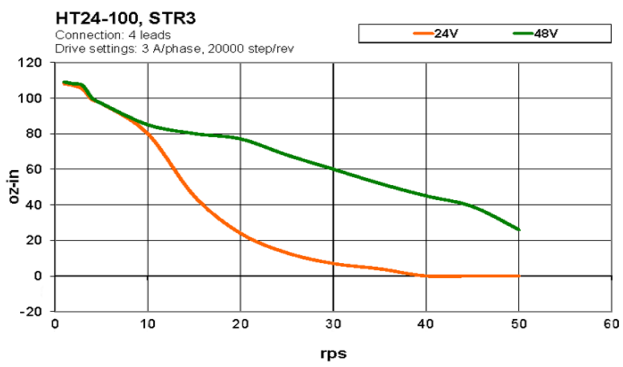
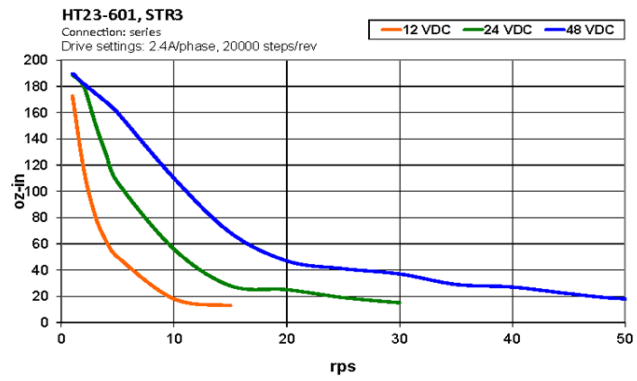
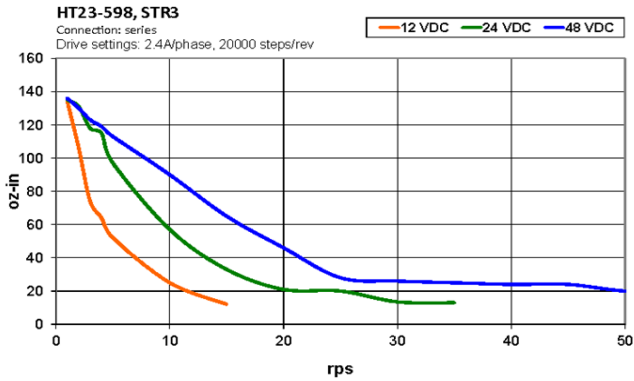

6.4 Motor Heating

Step motors convert electrical power from the driver into mechanical power to move a load. Because step motors are not perfectly efficient, some of the electrical power turns into heat on its way through the motor. This heating is not so much dependent on the load being driven but rather the motor speed and power supply voltage. There are certain combinations of speed and voltage at which a motor cannot be continuously operated without damage.

We have characterized the recommended motors in our lab and provided a table and several curves showing the maximum duty cycle versus speed for each motor at commonly used power supply voltages. Please refer to this information when planning your application.

Please also keep in mind that a step motor typically reaches maximum temperature after 30 to 45 minutes of operation. If you run the motor for one minute then let it sit idle for one minute that is a 50% duty cycle. Five minutes on and five minutes off is also 50% duty. However, one hour on and one hour off has the effect of 100% duty because during the first hour the motor will reach full (and possibly excessive) temperature.

The actual temperature of the motor depends on how much heat is conducted, convected or radiated out of it. Our measurements were made in a 40°C (104°F) environment with the motor mounted to an aluminum plate sized to provide a surface area consistent with the motor power dissipation. Your results may vary.

Motor	Connection	Current Setting (A)	Max Duty Cycle at 40°C Ambient		
			12VDC	24VDC	48VDC
HT08-020	4 leads	0.4	100%	100%	NR
HT08-021	4 leads	0.4	100%	100%	NR
HT11-012	4 leads	1.20	100%	100%	NR
HT11-013	4 leads	1.20	100%	100%	NR
HT17-268	parallel	1.6	100%	100%	see chart
HT17-271	parallel	2.0	100%	100%	see chart
HT17-275	parallel	2.0	100%	100%	see chart
HT23-595	series	2.40	100%	100%	100%
HT23-598	series	2.40	100%	100%	100%
HT23-601	series	2.40	100%	100%	100%
HT24-100	4 leads	3	100%	100%	100%

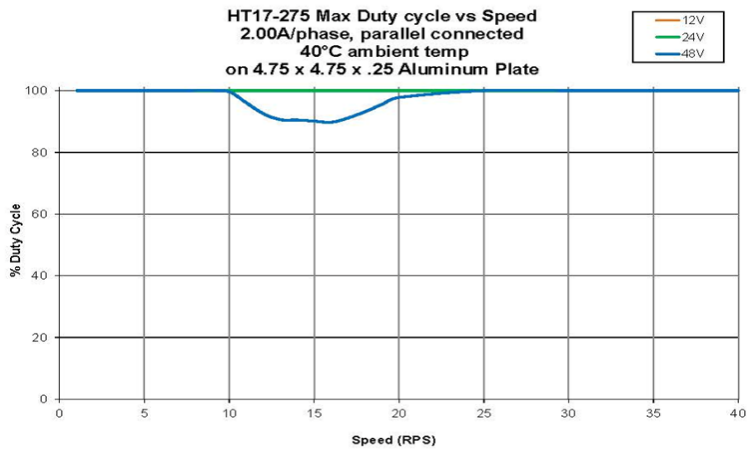
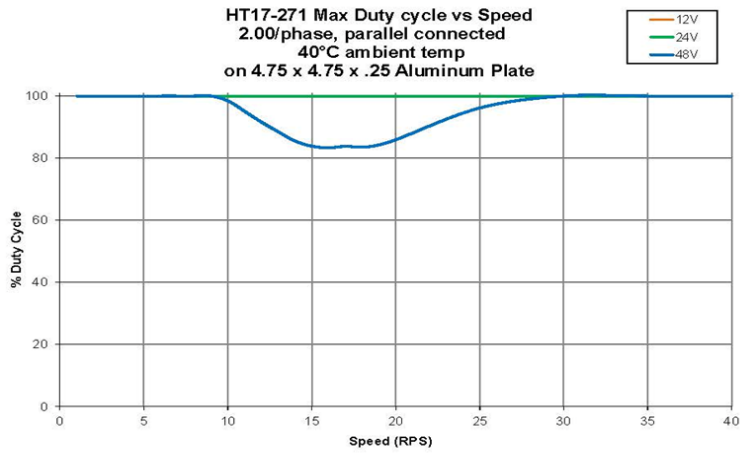
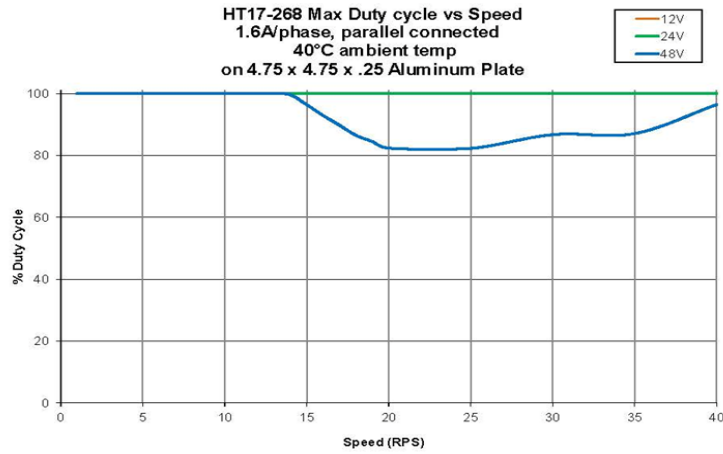

6.5 Mating Connectors

Connector	Manufactures	Model number
Power	DEGSON	15EDGK-5.08-02P-14-00AH
Motor	DEGSON	15EDGK-3.81-04P-14-00A(H)/
Input/Output	DEGSON	15EDGK-3.5-06P-14-00A(H)/



Applied Motion Products, Inc.
(800) 525-1609
www.applied-motion.com