

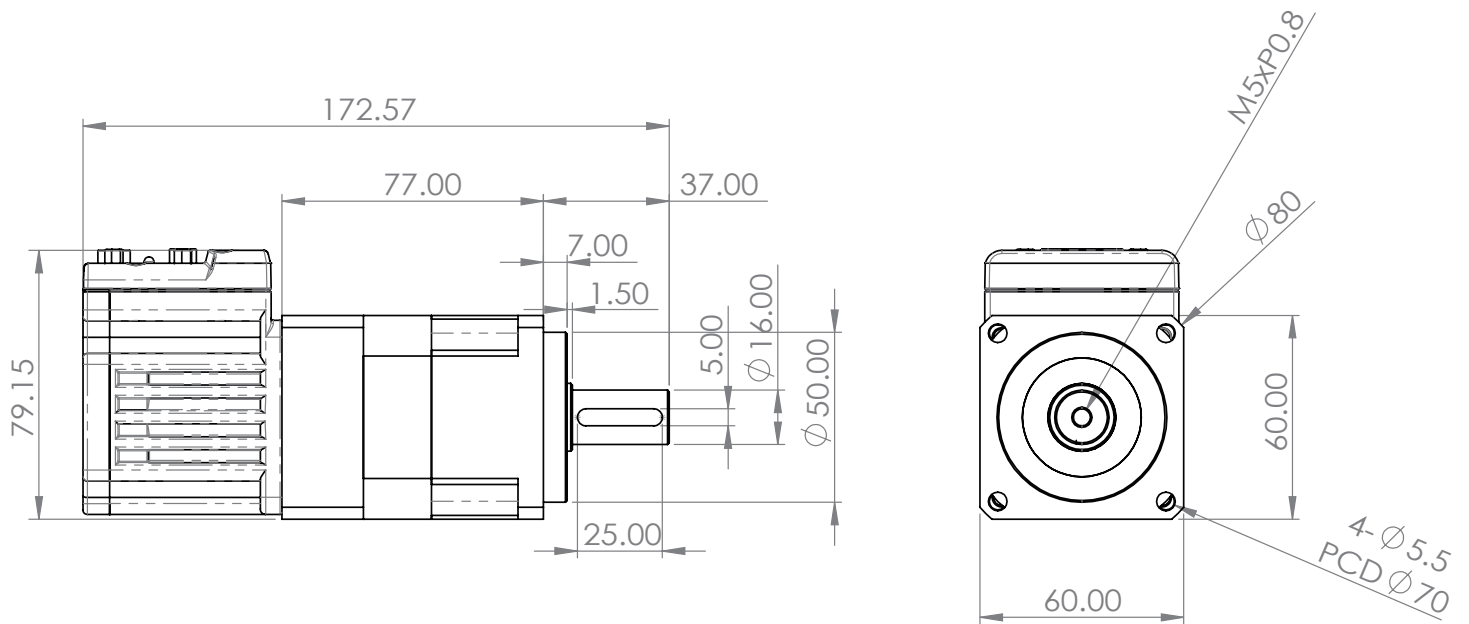

# 尺寸

## 單節 減速比 $i=3\sim 10$



## 雙節 減速比 $i=15\sim 100$

