



SGER
伺服減速機

特色

- ✓ 高剛性、高精度
- ✓ 增大扭矩、解析度及克服慣量的能力
- ✓ 選購90度可適應機台空間設計

規 格

馬達	伺服馬達	TSM17Q-2RG																			
編碼器解析度	Counts/Rev	20000																			
減速機形式	HER042	單節									雙節										
減速機比數	Ratio	3	4	5	6	7	8	9	10	15	20	25	30	35	40	50	60	70	80	90	100
保持轉矩	Nm	1.26	1.68	2.1	2.52	2.94	3.36	3.78	4.2	6.3	8.4	10.5	12.6	14.7	16.8	21	25.2	29.4	33.6	37.8	42
最大轉矩	Nm	1.59	2.12	2.65	3.18	3.71	4.24	4.77	5.3	7.95	10.6	13.3	15.9	18.6	21.2	26.5	31.8	37.1	42.4	47.7	53
額定轉速	rpm	1000	750	600	500	429	375	333	300	200	150	120	100	86	75	60	50	43	38	33	30
最大轉速	rpm	2000	1500	1200	1000	857	750	667	600	400	300	240	200	171	150	120	100	86	75	67	60
標準背隙	Backlash	≤ 7									≤ 9										
效率	%	≥ 97									≥ 94										
重量	Kg	0.5									0.8										
噪音值	dB(A)	≤ 56																			

產品型號

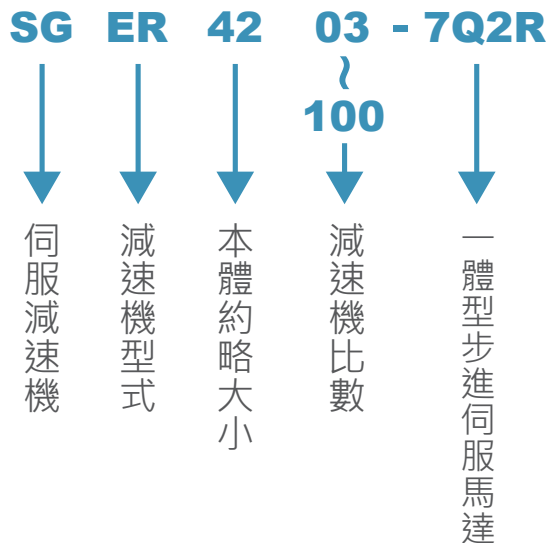

尺寸

單節 減速比 $i=3\sim 10$

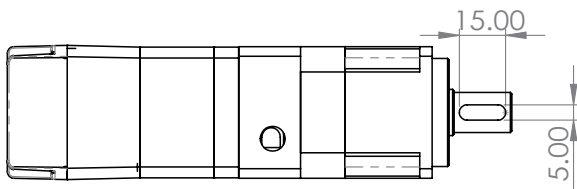
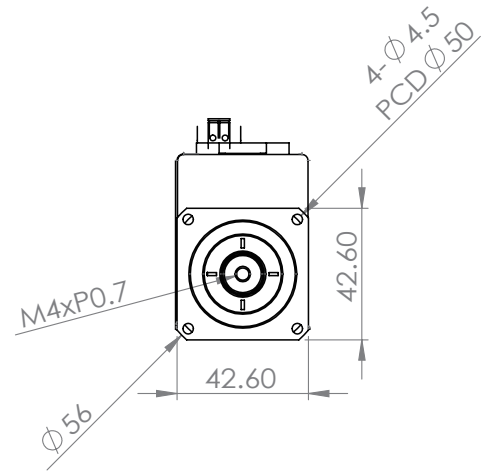
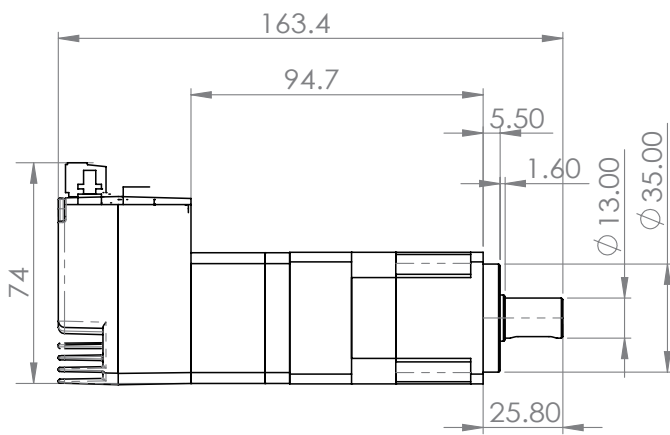

雙節 減速比 $i=15\sim 60$

