

SERVO DRIVES



The wide range of drive products allows rapid implementation of simple applications with two end positions, up to complex, high-precision multi-axis applications with synchronization to a main electronic shaft.

The servo drives cover a wide range in terms of performance. Controlling small actuators with low power as well as high-power servomotors with direct feed from the three-phase network can be realized.

LinMot Servo Drives

LinMot Servo Drives are highly integrated inverters with one or more power elements, for controlling the motors, and an intelligent control element with integrated position regulation. The control element performs all drive-related control and monitoring functions. It allows direct position set points, or travel along internally stored motion profiles from the overlaid control, using simple analog or digital signals. Additionally, using the technology functions or a customer-specific software application, complete sequences or functions can be implemented for customerspecific applications.

APPLICATION SOFTWARE

Using a software application, customer-specific applications can be programmed directly in the drive. This is mainly an advantage when very fast sequences need to be implemented, for which the communication speed or computing power of the overlaid control are not sufficient.

TECHNOLOGY FUNCTIONS

Technology functions are generally available functional blocks that provide a complete solution for standard applications. The technology function can take over complete sequence control of a process. With the technology function "winding textile yarns", only a few parameters are provided by the overlaid control, such as the number of windings. The complete winding process then takes place automatically.

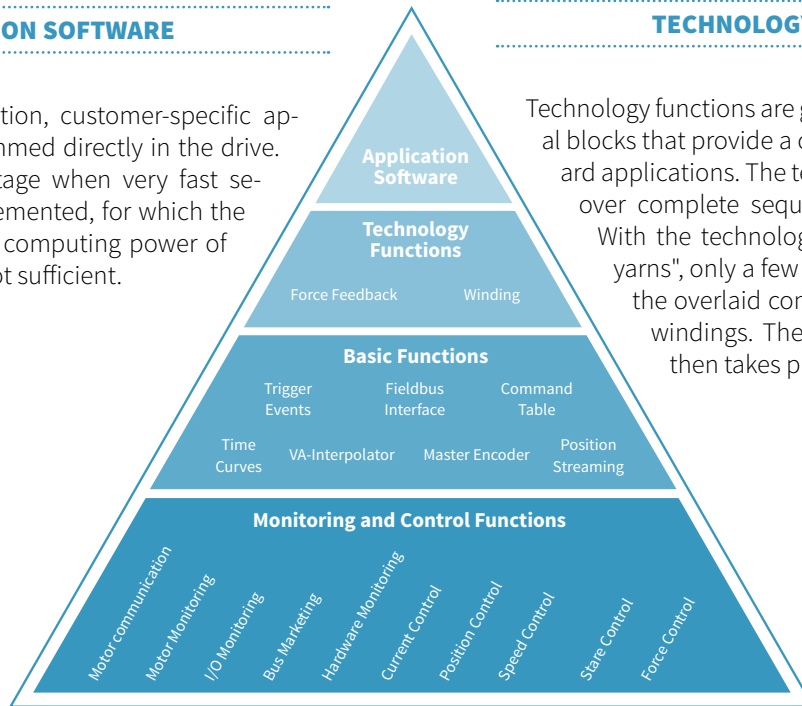

BASIC FUNCTIONS

The basic functions include communication with the overlaid control, generation of target values for speed and acceleration-limited point-to-point motions, travel along motion profiles, synchronization of drives to an electronic main or master shaft, and synchronization in multi-axis applications.

MONITORING AND CONTROL

The basic functions of the Servo Drive, such as position and current control; control and monitoring of the power element; and monitoring the motor temperature, power, and position are handled by the control, monitoring, and regulation element, which also controls the entire finite state machine of the drive.

SPS LIBRARIES AND PROGRAMMING EXAMPLES

LinMot Drives have all common fieldbus interfaces available for connection to a master controller. In order to realize simple control concept integration, extensive function blocks and programming examples are provided for the customer. These function blocks allow for direct and quick LinMot drive integration. The function blocks run standard functions as well as commands such as drive parameterization and configuration directly from the controller. The complete drive

configuration of the corresponding axis is thus stored on the controller. Maintenance or replacement can be easily realized via automatic drives detection and configuration over the communication bus. Thus manual and time-consuming configuration of the drives in case of failure is eliminated.

Characteristics

POINT-TO-POINT MOTIONS

Because of their high dynamic capabilities, long life, and ability to travel to several positions, LinMot linear motors are often used as a replacement for pneumatic cylinders.

Various end positions can be stored in the drive and are invoked via digital signals, just as with a pneumatic cylinder. Once the end position is reached, this is reported to the overlaid control via the In-position signal on a digital output. Speed and acceleration can be configured freely for each motion.

NC MOTION

Travel along paths from an overlaid NC drive can be implemented via the +/-10V interface, or in streaming mode (PVT, PV).

The predetermined points are calculated rapidly, so that even irregular and complex curves are realized dynamically.

HIGH-END APPLICATIONS

Complex applications with synchronization to a main or master shaft can be implemented without trouble using the integrated master encoder interface. All incoming signals from the main shaft are processed by the LinMot Drive and depend on the movement type of the linear motor.

Together with a high-resolution, external position sensor, even high-precision positioning tasks in μm range can be handled.

MULTI-AXIS OPERATION

In multi-axes or linked operation, the master encoder interface can control both individually and synchronous to a main or master shaft.

For complex designs, several axes can be synchronized in master-booster or master-gantry mode. This allows simple implementation of portal designs with two synchronized axes, which are controlled by the overlaid control as a single axis.

LINEAR AND ROTARY DRIVES

Using LinMot Servo Drives, rotary servomotors can be used as well as linear motors, or any 1/2/3-phase actuators.

Primarily in assembly automation and feeding applications, small, light brushless DC motors (EC motors) are often needed to rotate a gripper about the Z-axis. The flexibility of the Servo Drive allows such rotary motors to be integrated into the existing controls concept in the same simple manner as linear motors.

STANDARDIZED DEVICE PROFILES

To simplify the integration of different axes, the C Series Servo Drives are equipped with PROFIdrive, Sercos III, SoE (SercosOver-Ethercat) and CoE (CiA402). By using device profiles, the integration of „foreign“ Drives in the motion control is simplified. Further positive aspects are the automatic data exchange in real time and the increase of determinism in the system.

PLUG AND PLAY

LinMot motors with the plug and play functionality are automatically recognized by the A1100 / C1200 / C1100 / E1200 / E1400 servo drives and are immediately ready for use.

The servo drive reads these values when it boots up, and sets the parameters accordingly. This automatic device detection eliminates the selection of the required model parameters from an extensive library. Without having the configuration software to boot, first commands can be sent directly by the PLC control.

INTEGRATED SAFETY FUNCTION

In order to prevent unintended startup, the model C1200 / C1100 / E1200 / E1400 drives have an STO function to safely shut off the output stage. The drive cannot produce any more force when shut off using the "Safe Torque Off" function. A functional safety is currently under preparation and can already be solved today with external components.

CERTIFICATION

The current LinMot Drives are marked with CE and approved as components according to the UL regulation for variable-frequency controllers. Thus they meet the requirements for the US and Canadian market.

Configuration with LinMot Talk

LinMot Talk configuration software is a Windows- based interface that supports the user during start-up and configuration of the LinMot Servo Drives. The software has a powerful, modular, graphical interface that covers all the tasks surrounding the LinMot Servo Drive. Using LinMot Talk PC interface, the engineer can configure LinMot servo drives. The motors are also monitored during operation and the current motion sequences are analysed (monitoring). The integrated control panel gives the user direct access to the control and status words, as well as all commands that are invoked by the upper-level controller.

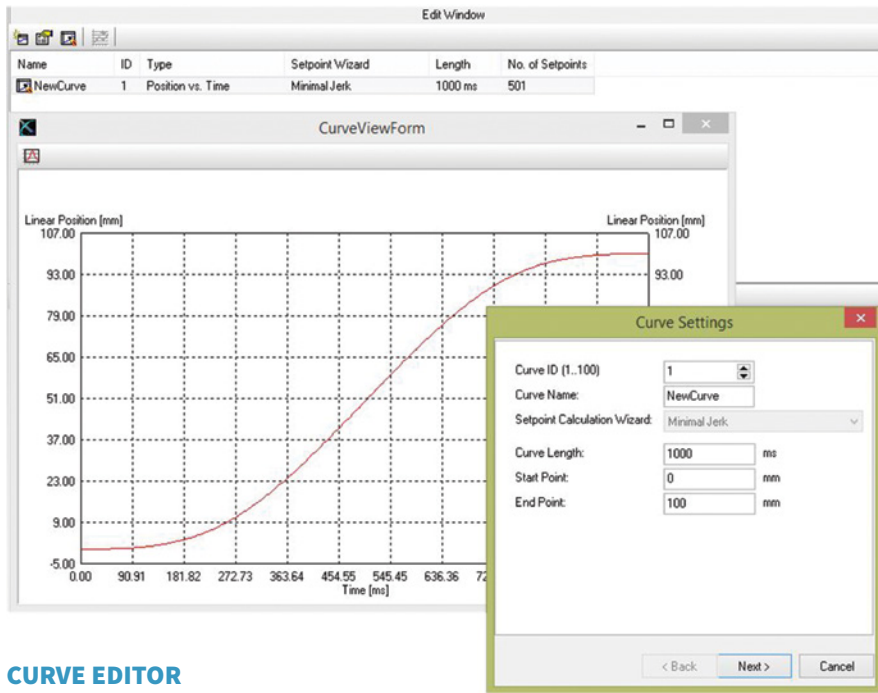

CURVE EDITOR

PARAMETERIZATION

Using the "Parameter Inspector," the drives are parameterized in a simple manner. The user has a wide range of adjustments available for operating modes, error management, warning messages, and regulating parameters. Entire parameter sets can be stored, loaded, and printed out.

CURVE EDITOR

The "Curve Editor" allows creation of travel curves. In addition, existing curves can be loaded, stored, edited, combined, and printed out. Further, complex motion sequences can be generated as desired in MS Excel, and loaded into the drive.

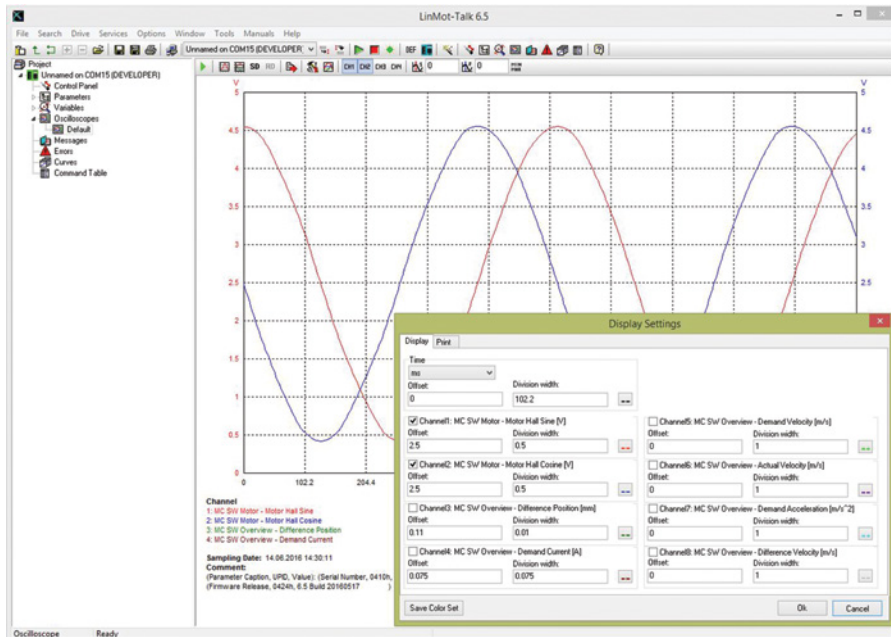

OSCILSCOPE

OPTIMIZATION

The integrated oscilloscope helps the user during start-up and optimization of the Parameterization Optimization Monitoring drive system. Internal variables, such as the target and actual position, can be shown in real time on the screen, and then printed out. The displayed data can be stored in CSV format for further processing in MS Excel, or stored for documentation purposes.

MONITORING

Using the "Error Inspector," the user can read out stored errors, as well as the currently active warnings and error messages in the LinMot Servo Drive. A list of the last error messages are stored in non-volatile memory on the Servo Drive, together with the operating hours counter.

Overview Servo Drives



A1100

Space-saving servo drive for instrument engineering



C1100

Compact drive for an ideal use in point-to-point applications.



C1200

Servo Drive for demanding tasks with axis, NC synchronization and an industrial ETHERNET interface.



E1200

High-End Servo Drive with configuration via ETHERNET.



C1400

Servo Drive with direct power supply for simple motions as well as complex axis synchronization. Designed to control the P10 motor family.



E1400

Servo Drive for P10 motors with direct main supply and 3x400 VAC technology. Equipped with an ETHERNET Config. interface.

Technical Specifications

	A1100	C1100	C1200
Motor Supply			
	24...72VDC	24...72VDC	24...72VDC
Motor Current			
	8A _{pk}	25A _{pk}	25A _{pk}
Control of			
LinMot Motors P0x/ PR01	•	•	•
LinMot Motors P10			
Rotary Motors		•	•
EC02 Motors		•	•
AC Servo Motors			
3rd Party Motors		•	•
Functionality			
	Point-to-Point	Point-to-Point	Point-to-Point
	Command Table	Closed Loop Force Control	Limited jerk motion commands
	Motion Profiles	Command Table	NC Motion
		Motion Profiles	Closed Loop Force Control
			Command Table
			Motion Profiles
Ethernet & Fieldbuses			
	CANOpen	PROFINET	PROFINET
		EtherCAT (LinMot Profile)	PROFINET Profidrive
		EtherCAT (CiA402)	EtherNet/IP
		EtherCAT (SoE)	Sercos III
		CANOpen	Powerlink
			LinUDP
			EtherCAT
			EtherCAT (CiA402)
			EtherCAT (SoE)
Interfaces			
Analog Inputs 0..10V / +-10V	1 / 0	1/1	1/1
Number of digital Inputs / Outputs	6 / 2	4/2	4/2
Brake Output	(-)	24V/0.5A	24V/0.5A
External Encoder			
		A/B/Z (RS422)	A/B/Z (RS422)
		SSI	SSI
		BISS	BISS
			EnDat
Timings			
Min. Bus Cycle Time	250 µs	250 µs	125 µs
PWM Frequency	16 kHz	16 kHz	16 kHz
Trigger Commands	≥ 250 µs	≥ 250 µs	≥ 125 µs
Position Drive	250 µs	250 µs	125 µs
Configuration			
RS 232	•	•	•
ETHERNET			•
ETHERNET –Maintenance			

11

E1200	C1400	E1400
24...72VDC	1x200...240VAC	3x400...480VAC
32A _{pk}	15A _{pk}	28A _{pk}
•	•	•
•	•	•
•	•	•
•	•	•
Point-to-Point	Point-to-Point	Point-to-Point
NC Motion	Limited jerk motion commands	Limited jerk motion commands
Master Encoder / CAM	NC Motion	NC Motion
Belt Synchronization	Master Encoder / CAM	Master Encoder / CAM
Master Booster (up to 4 slaves)	Belt Synchronization	Belt Synchronization
Master Gantry (up to 4 slaves)	Closed Loop Force Control	Master Booster (up to 4 slaves)
Winding Application	Command Table	Master Gantry (up to 4 slaves)
Closed Loop Force Control	Motion Profiles	Winding Application
Command Table		Closed Loop Force Control
Motion Profiles		Command Table
		Motion Profiles
PROFINET	PROFINET	PROFINET
PROFINET Profidrive	PROFINET Profidrive	PROFINET Profidrive
EtherNet/IP	EtherNet/IP	EtherNet/IP
Sercos III	Sercos III	Sercos III
Powerlink	Powerlink	Powerlink
LinUDP	LinUDP	LinUDP
Profibus DP	CANOpen	Profibus DP
CANOpen	EtherCAT	CANOpen
EtherCAT	EtherCAT (CiA402)	EtherCAT
EtherCAT (CiA402)	EtherCAT (SoE)	EtherCAT (CiA402)
EtherCAT (SoE)		EtherCAT (SoE)
LinRS		LinRS
2/1	1/1	2/1
8	4/2	8
24V/1.0A	24V/1.5A	24V/1.5A
A/B/Z (RS422)	A/B/Z (RS422)	A/B/Z (RS422)
Sin/Cos (1Vpp)	SSI	SSI
SSI (only position recovery)	BISS	BISS
	EnDat	EnDat
200 µs	250 µs	250 µs
20 kHz	8 kHz	8 kHz
≥ 100 µs	≥ 125 µs	≥ 125 µs
100 µs	125 µs	125 µs
•	•	•
•	•	•
•	•	•



LinMot®

LinMot®

LinMot®

S2 1 4 5 8
S1 1 2 3 4 5 6 7 8
CTS 206-8 T340
ID LOW ID HIGH

S2 1 4 5 8
S1 1 2 3 4 5 6 7 8
CTS 206-8 T340
ID LOW ID HIGH

S2 1 4 5 8
S1 1 2 3 4 5 6 7 8
CTS 206-8 T340
ID LOW ID HIGH

X33 STO RELAYS

X33 STO RELAYS

X33 STO RELAYS

WARN ERROR EN 24V OK

WARN ERROR EN 24V OK

WARN ERROR EN 24V OK

11 AnIn-
10 AnIn+
9 AnIn
8 In
7 In
6 In
5 In
4 Out
3 Out
24VDC
DGND

X4 LOGIC SUPPLY / CONTROL 1 11

11 AnIn-
10 AnIn+
9 AnIn
8 In
7 In
6 In
5 In
4 Out
3 Out
24VDC
DGND

C1100

C1100

X19 SYSTEM 1 8

SERIES E1200



- ✓ Absolute / relative positioning commands
- ✓ Limited jerk motion commands
- ✓ Time Curves
- ✓ Real Time (Streaming)
- ✓ Synchronous control (Drive profiles)
- ✓ Master Encoder Synchronization (In/Out)
- ✓ PLC or Stand-Alone Solutions
- ✓ Industrial Ethernet Configuration / Remote Access Ethernet
- ✓ Digital and Analog IO's
- ✓ Interface for optional incremental and absolute sensor
- ✓ Position Encoder Simulation (RS 422)
- ✓ Master / Slave Solutions
- ✓ ± 10 VDC Force Control
- ✓ Supports Plug and Play
- ✓ CE

Servo Drive E1200

Series E1200 Servo Drives are modular axis drives, with 32-bit position resolution and an integrated power stage, for linear and rotary motors.

The drives are suitable for simplest, standard, and high-end positioning tasks, across the entire force range of the LinMot product range.



CONNECTION TO MACHINE DRIVE

The Series E1200 Servo Drives can be actuated by machine controls from many manufacturers or brands, via digital inputs and outputs, RS232 or RS485 serial interface, CanBus CANopen and DeviceNet interfaces, Profibus DP, or industrial ETHERNET.

PROCESS AND SAFETY INTERFACES

Fast process interfaces for direct processing of sensor signals are available as freely programmable analog and digital inputs, a fast trigger input, and a capture input.

The safe pulse inhibitor on Servo Drive with fieldbus interfaces or industrial ETHERNET allows safe stop of the drives via control signals, per EN 954-1, without interrupting the power supply.

LOGIC AND POWER SUPPLY

The Servo Drives have two separate power supply inputs for the logic and power elements.

In an E-stop and safe stop of the drive, only the power element supply is cut off from the drive. The logic supply and the drive continue to run.

This has the advantage that the drive and linear motor do not need to be reinitialized when the machine is restarted, since all process data, including the current position of the linear motor, are still up to date.

System Integration

Flexible hardware enables control of many 1/2/3- phase motors. Thus, low-power rotary servomotors, such as brushless DC motors, can be integrated in the same controls concept.

Additionally, the drives can be equipped with optional peripherals, such as reference and end stop switches, high-precision external position sensors, or a mechanical holding brake.

Series E1200 Servo Drives have analog and digital inputs and outputs, serial interfaces, fieldbusses, and ETHERNET connections. The user is therefore not dependent on the selection of the overlaid drive. An appropriate interface is available, with associated protocols, for any PLC or IPC solution.

With flexibility and a compact form factor, LinMot Series E1200 Servo Drives provide a complete solution for a flexible drive concept in single and multiple axes applications, with linear motors and other actuators.

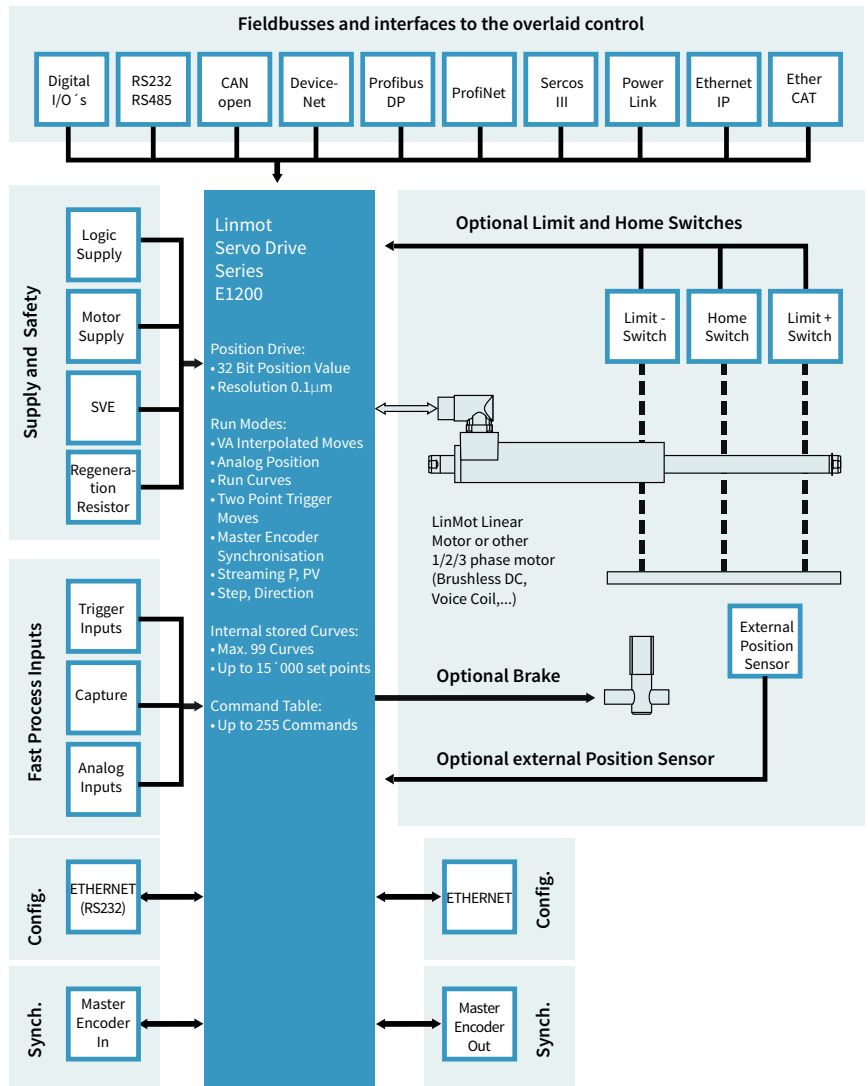

MASTER ENCODER

For synchronization to a mechanical master shaft, or a rotating main drive, the Axis (linear motors and rotary motors) can be coupled to an electronic main shaft via the Master Encoder Interface.

The encoder signal from the main shaft can be passed through by the Master Encoder Interface, so that any number of linear motors can be synchronized to the main shaft.

MOTOR INTERFACES

E1200 Servo Drives provide all necessary interfaces to operate linear or rotary motors with optional external peripherals, such as end position and reference switches, a mechanical brake, or a high-resolution external position sensor.

In special applications, two drives can be synchronized with each other using the synchronization interface in master booster mode.

CONFIGURATION

Parameterization and configuration of the Servo Drive is done via the Ethernet interface on the front side for simultaneous configuration of several drives.

LinMot Talk user-friendly PC software is available for configuration. In addition to online documentation, LinMot Talk provides extensive debugging tools, such as an oscilloscope and an error inspector, for simple and rapid start-up of the Axis.

Fieldbus and ETHERNET drives can also be configured directly by the overlaid control.

INTERPOLATED MOVES

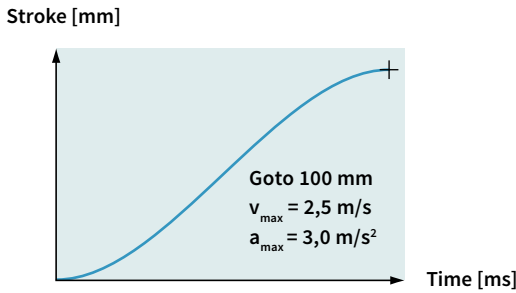

For direct position targets, using absolute or relative positioning, the desired position is reached using acceleration and velocity-limited motion profiles or jerk optimized profiles (jerk limited and Bestehorn). Positioning commands can be invoked via the serial interfaces, CANopen, DeviceNet, Profibus, Ethernet or a trigger input.

Stroke range:	±100 m
Position Resolution:	0.1 µm (32Bit)
Velocity Resolution:	1.0 µm/s (32Bit)
Acceleration Resol.:	10.0 µm/s ² (32Bit)

TIME CURVES

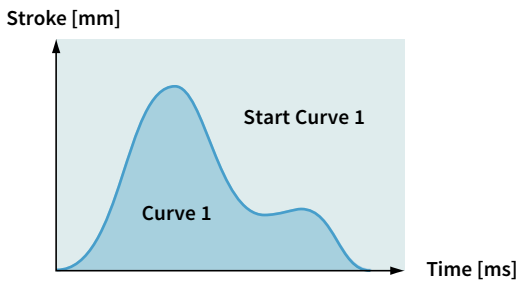

Up to 100 different time curves can be stored Series E1200 drives, with up to 16,000 individual waypoints. The motor can thus travel along time curves of any complexity, such as those generated by CAD programs and stored in the drive (Excel CSV format). The time curves can be invoked via the serial interface, fieldbusses, ETHERNET, or the trigger input.

Stroke range:	±100m
Position Resolution:	0.1 µm (32Bit)
Motion profiles:	Max. 100 Time Curves
Curve points:	Max. 16'000 points

PROFILED MOVES

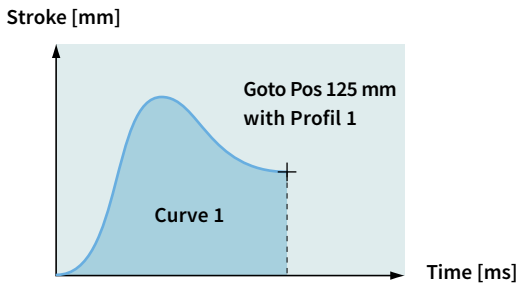

For travel to an absolute position, or shifting by a relative position, any desired motion rules can be stored besides the VA interpolator. They are stored in the drive as motion profiles (Excel CSV format). The positions can be approached, for example, with a sinusoidal motion to optimize power loss, or special reverse optimized motion profiles.

Stroke range:	±100m
Position Resolution:	0.1 µm (32Bit)
Motion profiles:	Max. 100 Time Curves
Curve points:	Max. 16'000 points

SETPOINT STREAMING

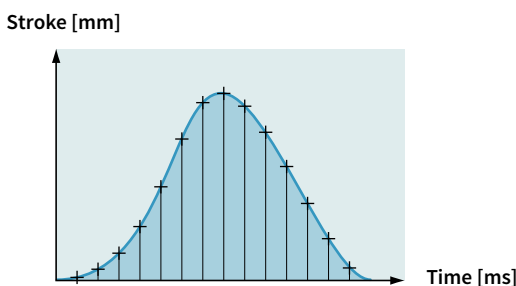

Overlaid NC drives with fieldbus or ETHERNET interfaces communicate with the Servo Drives via "Position Streaming". The position and velocity calculated in the overlaid control is transmitted to the Servo Drive cyclically. The P, PV, or PVT mode is available for this transmission.

Position Resolution:	32 Bit
Velocity Resolution:	32 Bit
Interpolator:	10 kHz
Cycle times:	0.4 - 5 ms

EASY STEPS

Input 1	Pos 125 mm
Input 2	Pos 250 mm
Input 3	Curve 1
Input 4	Pos -30 mm
Input 5	Pos +12,5 mm
Input 6	Curve 2
Input 7	Pos 2 mm
Input 8	Pos -12,5 mm

With the Easy Steps function, up to 8 positions or independent travel commands can be stored on the drive, and addressed via 8 digital inputs or fieldbus interfaces/ETHERNET.

Digital inputs: max. 8
Interface: X4
Scanning rate: 200 µsec

COMMAND TABLE

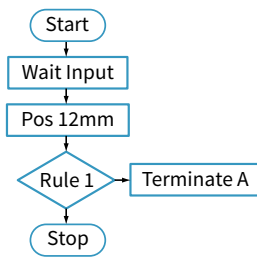

Entire motion sequences with up to 255 individual motion commands can be stored in the Command Table. This is primarily advantageous if complete motion sequences need to be executed very quickly, without dead time from the overlaid drive. In the Command Table, the programmer has access to all motion commands, internal parameters, and digital inputs and outputs.

Commands: max. 255
Cycle time: 100 µsec

MASTER ENCODER SYNCHRONIZATION (MT)

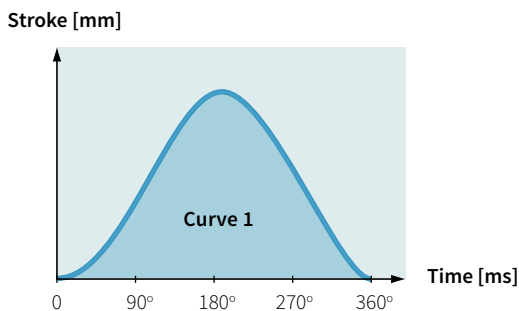

For synchronization to an external main or master shaft, the linear motor travels along the motion profiles stored in the drive, at the machine speed (machine angle 0...360°). Using this function, mechanical cam discs can be replaced with highly dynamic linear motors. The motion profiles can be freely defined, and the correct motion profile can be invoked during product changeover with no changeover time.

Motion profiles: Max. 100 curve profiles
Curve points: Max. 16'000 points
Encoder Counter: 32 Bit
Encoder Input: A/B/Z (RS422)
Max. counting frequency: Max. 4.5 MHz

BELT SYNCHRONIZATION

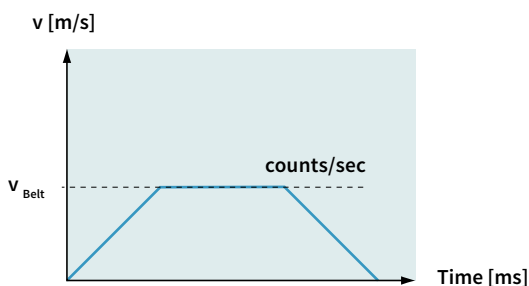

Synchronization to a belt speed can be done using the Master Encoder Interface or Step/Direction/ Zero interface. Applications such as the "flying saw", synchronous loading or unloading, synchronous filling or labeling of bottles or containers on a conveyor belt, and many other applications can be implemented in this way.

Encoder Counter: 32 Bit
Encoder Input: A/B/Z (RS422), max. 5 MHz
 STEP/DIR/ZERO
Max. counting frequency: Max. 4.5 MHz

ANALOG POSITION

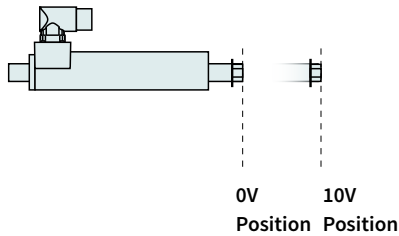

For an analog position target, the linear motor travels to a position proportional to the input voltage. The position is either scanned continuously, or only after a rising edge of the trigger signal. In order to prevent uncontrolled jumps in position, the motor travels to the positions with a programmable maximum acceleration and velocity (VA interpolator).

Inputs:	Analog Input X4 or X20
Voltage range:	0-10VDC or ±10V
Resolution:	12 Bit
Scanning rate:	>=100 µsec (adjustable)

EASY STEPS PARAMETER SCALE

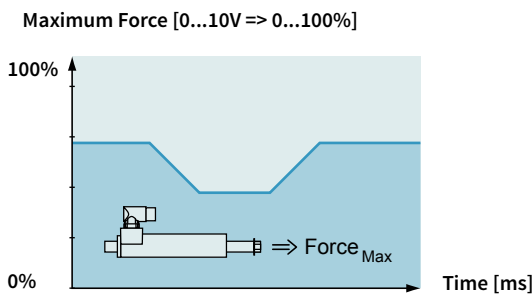

Easy Steps provide the ability to parameterize internal parameters using two analog inputs. If, for example, the maximum motor current is read at an analog input, then the maximum motor force can be provided as analog for freely programmable joining processes.

Inputs:	2 x Analog (X4.4, X4.7)
Voltage range:	0-10VDC
Resolution:	12 Bit
Scanning rate:	200 µsec

CLOSED LOOP FORCE CONTROL

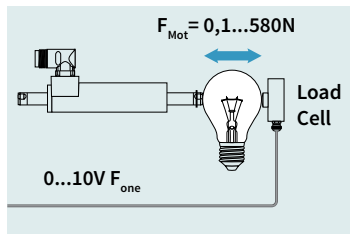

Using the force control technology function, precise joining processes can be implemented reliably and reproducibly with high-precision force control. For force control, the current motor force is measured with a load cell and controlled in the drive. Joining process or quality checks with high requirements for applied force can be implemented.

Analog Input:	0-10V or ±10V
Resolution:	12 Bit
Min. Force Resolution:	0.1N

WINDING APPLICATION

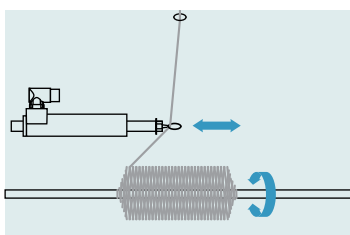

For winding textile yarns, glass fiber optics, or wires, a complete functional block is available that controls the entire sequence of a complete winding process.

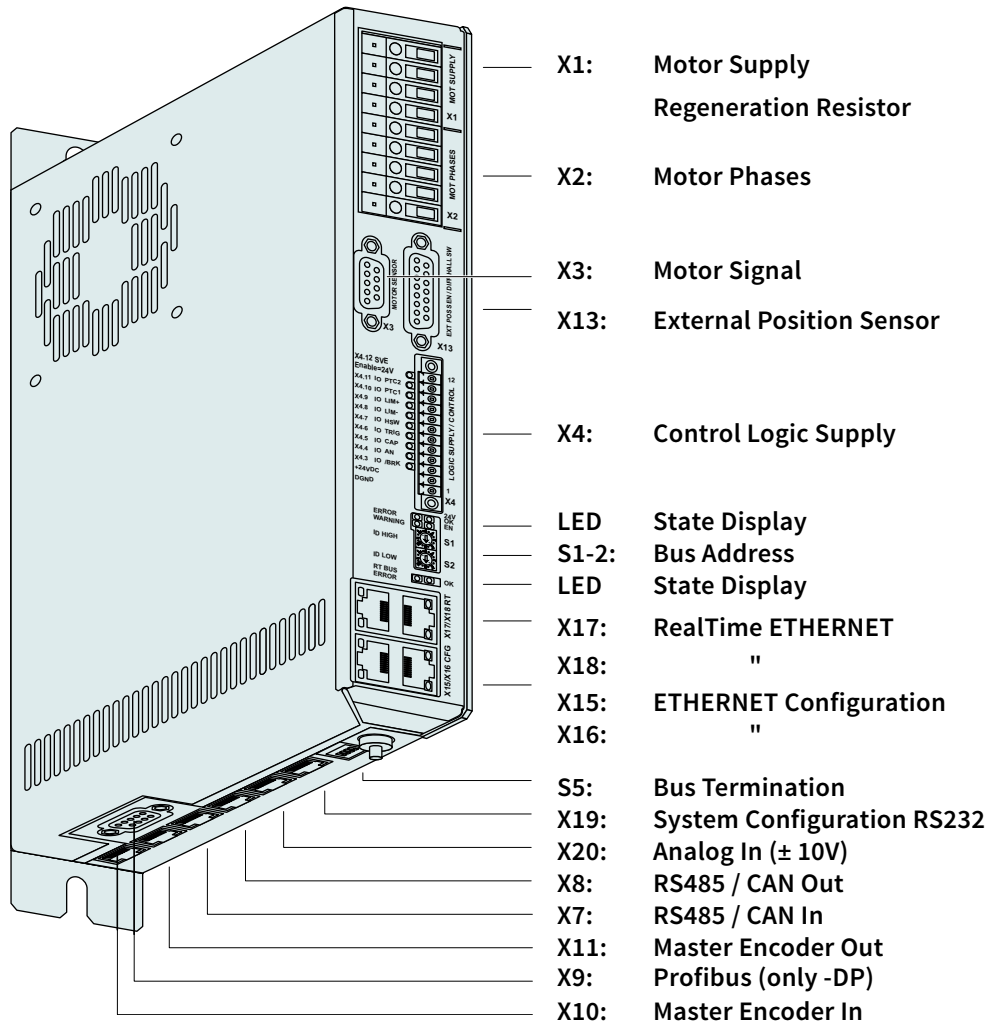

Interfaces	E1250-PL-UC	E1250-PN-UC	E1250-SC-UC	E1250-IP-UC	E1250-LU-UC	E1250-EC-UC	E1250-SE-UC	E1250-DS-UC	E1230-DP-UC	E1200-GP-UC
CANopen										•
LinRS										•
POWERLINK	•									
PROFINET		•								
sercos			•							
sercos over EtherCAT							•			
ETHERNET IP				•						
LinUDP					•					
EtherCAT						•				
ETHERCAT CIA402								•		
PROFIBUS-DP									•	

- E1250-PL-UC
- E1250-PN-UC
- E1250-PD-UC
- E1250-SC-UC
- E1250-IP-UC
- E1250-LU-UC
- E1250-EC-UC
- E1250-SE-UC
- E1250-DS-UC
- E1200-GP-UC

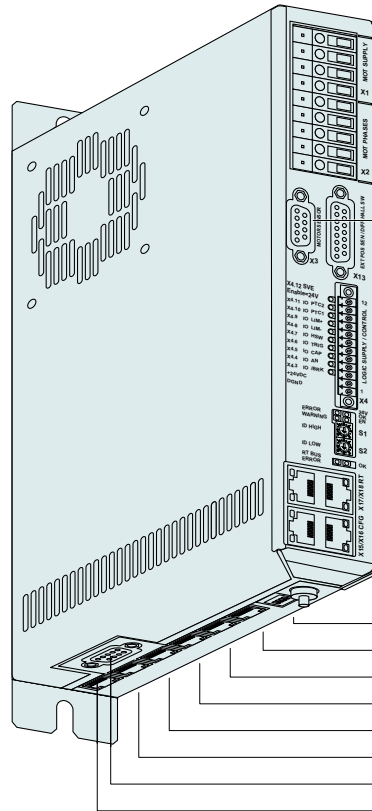

- X1: Motor Supply
Regeneration Resistor
- X2: Motor Phases
- X3: Motor Signal
- X13: External Position Sensor
- X4: Control Logic Supply
- LED State Display
- S1-2: Bus Address
- LED State Display
- X17: RealTime ETHERNET
- X18: "
- X15: ETHERNET Configuration
- X16: "
- S5: Bus Termination
- X19: System Configuration RS232
- X20: Analog In ($\pm 10V$)
- X8: RS485 / CAN Out
- X7: RS485 / CAN In
- X11: Master Encoder Out
- X9: Profibus (only -DP)
- X10: Master Encoder In

- » Absolute & Relative Positioning
- » Travel Along Time Curves
- » Positioning using Motion Profiles
- » Internally stored Motion Commands
- » Internally stored Motion Sequences
- » Master Encoder Synchronization
- » Synchronization to Belt Speed
- » Position Streaming
- » Analog Position Target
- » Analog Parameter Scaling
- » Winding Function Block
- » Force Control Technology Function
- » Customer-Specific Functions

INDUSTRIAL ETHERNET

Series E1200 drives allow integration of LinMot linear motors in controls concepts with industrial ETHERNET interfaces. The user can integrate Series E1200 drives regardless of the provider of the overlaid control.

LinMot drives are available with common industrial ETHERNET protocols. Since all ETHERNET drives have the same motion command interface, and the control and status word are identical, software blocks that have been implemented once can be transferred to other drives without a problem.

TECHNICAL DATA

Series E1200 Servo Drives support the following industrial ETHERNET protocols:

- » Profinet
- » ETHERNET IP
- » PowerLink
- » EtherCat
- » Sercos III

The appropriate drive is available for each protocol.

TECHNICAL DATA

Type: Realtime ETHERNET
Switch/Hub: Integrated 2-Port Hub/Switch
Transfer rate: 10/100MBit/sec

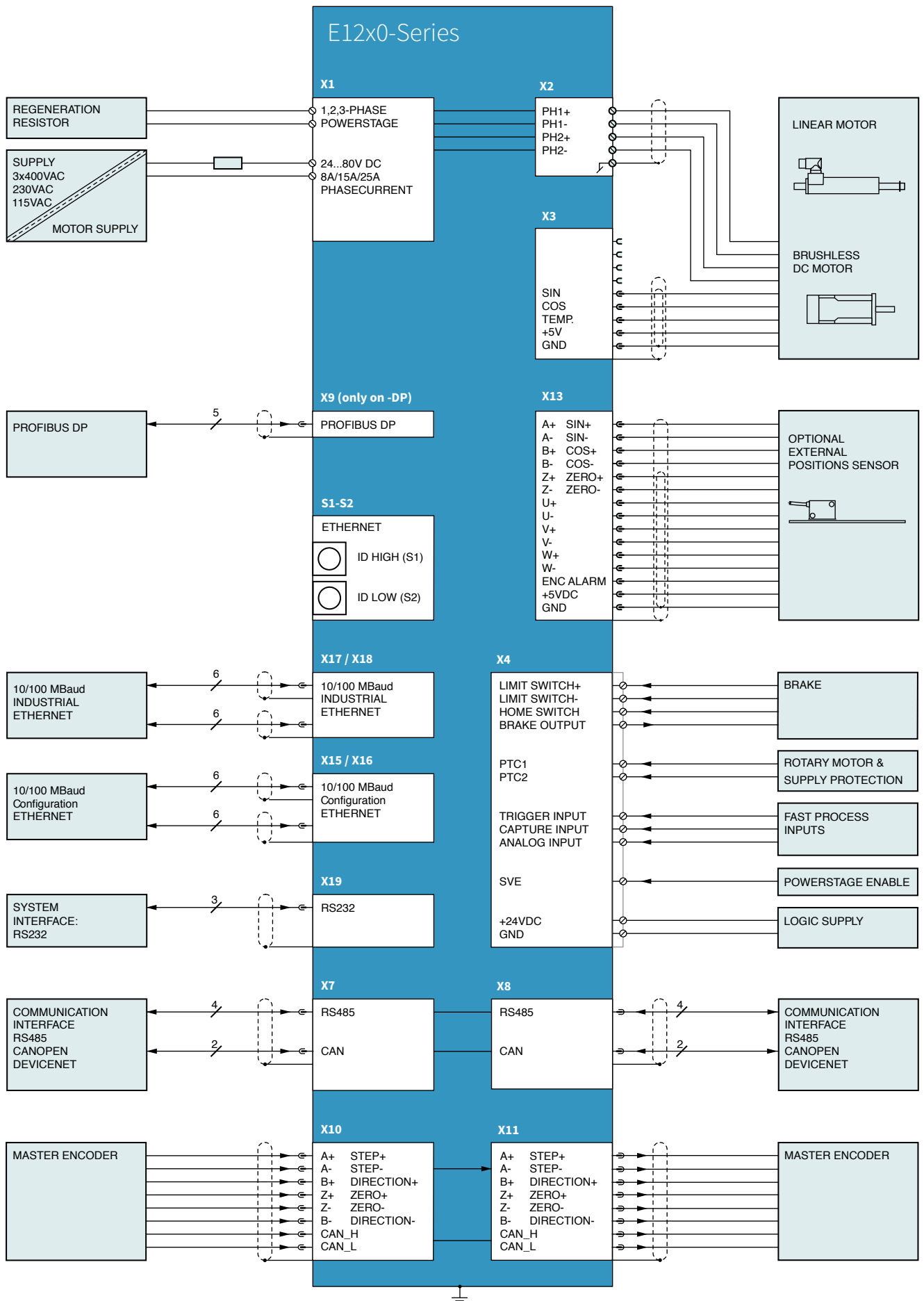

X1 MOTOR SUPPLY / REGENERATION RESISTOR

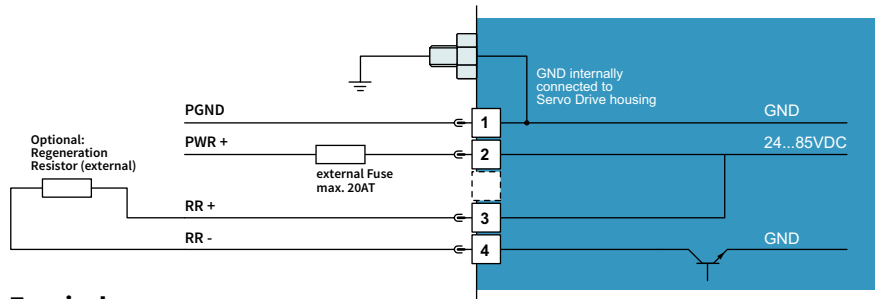
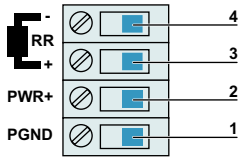

Screw Terminals:

External Regeneration Resistor (RR01-10/60, Art. Nr. 0150-3088)
 External Fuse: max. 20AT
 Supply nominal 72VDC (24...85VDC)
 (See chapter Power Supply Requirements for compatible power supplies.)
 Absolute max. Rating 72VDC +20%.

If motor supply voltage is exceeds 90VDC, the drive will go into error state.

- » Tightening torque: 0.5 - 0.6 Nm (4.4 – 5.3 lbin)
- » Screw thread: M2.5
- » Use 60/75°C copper conductors only
- » Conductor cross-section: use only 2.5 mm² / AWG 14
- » Stripping length: 13-15 mm
- » Max. length: 4 m

X2 MOTOR PHASES

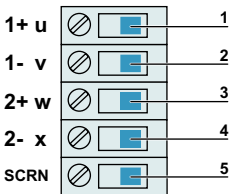

Nr	Designation	LinMot Linear Motor	Color	3-Phase-Motor
1	PH1+ /U	Motor Phase 1+	red	Motor Phase U
2	PH1- /V	Motor Phase 1-	pink	Motor Phase V
3	PH2+ /W	Motor Phase 2+	blue	Motor Phase W
4	PH2- /X	Motor Phase 2-	grey	Motor Phase X
5	SCR N	Shield		

Screw Terminals:

- » Tightening torque: 0.5 - 0.6 Nm (4.4 – 5.3 lbin)
- » Screw thread: M2.5
- » Use 60/75°C copper conductors only
- » Conductor cross-section: 0.5 – 2.5 mm² (depends on Motor current) / AWG 21 -14
- » Stripping length 13-15 mm

X3 MOTOR ENCODER

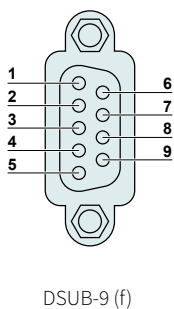

Nr	LinMot Linear Motor	3-Phase-Motor
1		
2		
3	+5VDC	+5VDC (Hall Supply)
4	Sensor Sine	Hall 1
5	Temperature In	Hall 3
6		
7		
8	AGND	AGND (Hall Supply)
9	Sensor Cosine	Hall 2
Case	Shield	



Use +5VDC (X3.3) and AGND (X3.8) only for motor internal hall sensor supply (max. 100mA).

Caution :

Do NOT connect AGND (X3.8) to ground or earth!

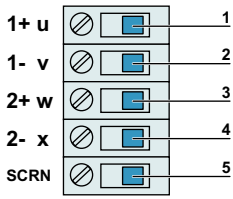

X2: Screw Terminals

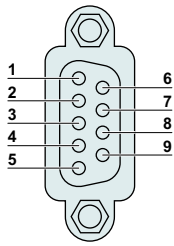

X3: DSUB-9 (f)

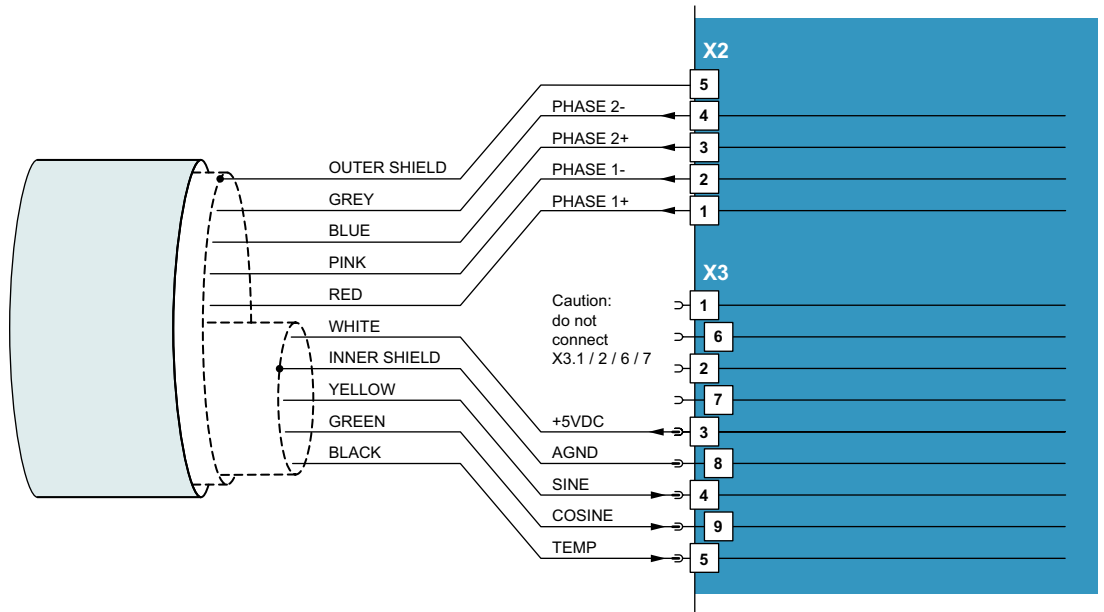

X4: 12PIN LOGIC CONTROL / SUPPLY

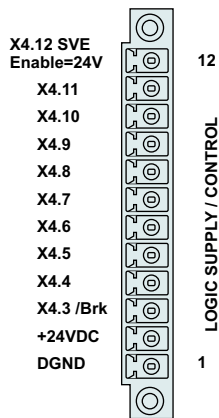

Phoenix MC1,5/12-STF-3,5 (delivered with drive)

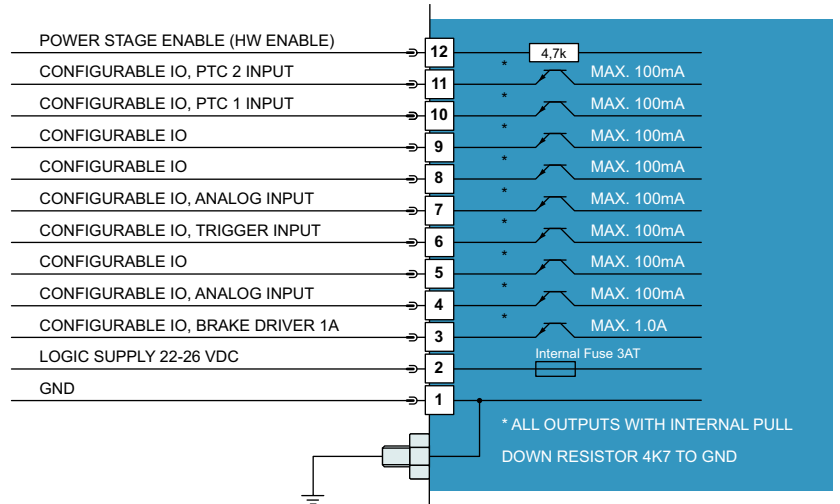

- Inputs (X4.3 .. X4.12):** 24V / 5mA (Low Level: -0.5 to 5VDC, High Level: 15 to 30VDC)
- Outputs (X4.4 .. X4.11):** 24V / max.100mA, Peak 370mA (will shut down if exceeded)
- Brake Output (X4.3):** 24V / max.1.0A

Input X4.12: SVE (PowerStage Enable) must be high for enabling the power stage). If it goes low for more than 0.5ms the PWM generation of the power stage is disabled by hardware.

Supply 24V / typ. 1.1A / max. 2.1A (if all outputs “on” with max. load and brake.)

- » Tightening torque: min 0.22Nm
- » Screw thread: M2
- » Use 60/75°C copper conductors only
- » Conductor cross-section: max. 1.5mm²
- » Internal Fuse (F2):3AT (slow blow, Schurter OMT125, 3404.0118.xx, UL File Number: E41599)



CAUTION: For continued protection against risk of fire, replace only with same type and rating of fuse.

X7 - X8 RS485/CAN

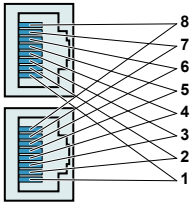

RJ-45

Nr		
1	RS485_Rx+	A
2	RS485_Rx-	B
3	RS485_Tx+	Y
4	GND	
5	GND	
6	RS485_Tx-	Z
7	CAN_H	
8	CAN_L	
Case	Shield	

- » Use twisted pair (1-2, 3-6, 4-5, 7-8) cable for wiring.
- » The built in CAN and RS485 terminations can be activated by S5.2 and S5.3.
- » X7 is internally connected to X8 (1:1 connection)

X9 PROFIBUS DP (ONLY AVAILABLE ON E1230-DP-UC)

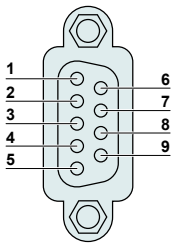

DSUB-9 (f)

Nr		
1	-	
2	-	
3	RxD/TxD-P	
4	CNTR-P	
5	GND	(isolated)
6	+5V	(isolated)
7	-	
8	RxD/TxD-N	
9	-	
Case	Shield	

Max. Baud rate: 12 Mbaud

X10-X11 MASTER ENCODER IN (X10) / MASTER ENCODER OUT (X11)

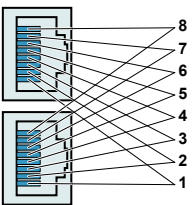

RJ-45

Nr	Incremental	Step/Direction	EIA/TIA 568A colors
1	A+	Step+	Green/White
2	A-	Step-	Green
3	B+	Direction+	Orange/White
4	Z+	Zero+	Blue
5	Z-	Zero-	Blue/White
6	B-	Direction-	Orange
7	CAN_H	CAN_H	Brown/White
8	CAN_L	CAN_L	Brown
Case	Shield	Shield	

Use twisted pair (1-2, 3-6, 4-5, 7-8) cable for wiring.

Master Encoder Inputs: Diff. RS422, max. counting frequency 25 Mcounts/s, quadrature evaluation, 40ns edge separation

Master Encoder Outputs: Amplified RS422 differential signals from Master Encoder IN (X10)

The CAN bus can be terminated with S5.4.

All devices, which are connected to X10/X11 must be referenced to the same ground.

X13 EXTERNAL POSITION SENSOR DIFFERENTIAL HALL SWITCHES / SSI

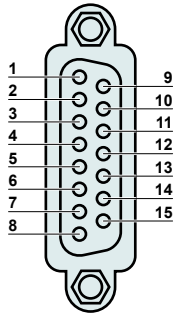

DSUB-15 (f)

Nr	ABZ with Hall Switches	Sin / Cos 1 Vpp	SSI (only position recovery)
1	+5V DC	+5V DC	+5VDC
2	9 A+	Sin+	
3	10 A-	Sin-	
4	11 B+	Cos+	
5	12 B-	Cos-	
6	13 Z+		Data+
7	14 Z-		Data-
8	12 Encoder Alarm	Encoder Alarm	
9	GND	GND	GND
10	13 U+		
11	14 U-		
12	15 V+		
13	16 V-		
14	17 W+		Clock+
15	18 W-		Clock-
Case	Shield	Shield	Shield

Position Encoder Inputs (RS422):

Encoder Simulation Outputs (RS422):

Differential Hall Switch Inputs (RS422):

Enc. Alarm In:

Sensor Supply:

Max. counting frequency: 25 Mcounts/s with quadrature decoding, 40ns edge separation
 Max Output Frequency: 2.5MHz, 5 M counts/s with quadrature decoding, 200ns edge separation
 Input Frequency: <1kHz
 5V / 1mA
 5VDC max 100mA

X15-X16 ETHERNET CONFIGURATION 10/100MBIT/S

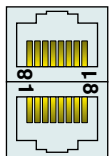

RJ-45

X15	Internal 2-Port 10BASE-T and 100BASE-TX Ethernet Switch with Auto MDIX. LEDs on the lower side of the device indicate "Link/Activity" per port, the upper ones are not used.
X16	

X17-X18 REALTIME ETHERNET 10/100 MBIT/S

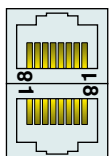

RJ-45

X17 RT ETH In	Specification depends on RT-Bus Type. Please refer to according documentation.
X18 RT ETH Out	

X19 RS232 CONFIGURATION

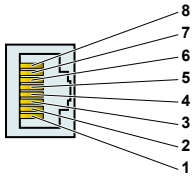

RJ-45

Nr	Description
1	Do not connect
2	Do not connect
3	RS232 RX
4	GND
5	GND
6	RS232 TX
7	Do not connect
8	Do not connect
case	Shield

Use isolated USB-RS232 converter (Art.-No. 0150-2473) for configuration over RS232.

X20 ANALOG IN (+-10V DIFFERENTIAL ANALOG INPUT)

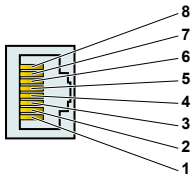

RJ-45

Nr	Description
1	Do not connect
2	Do not connect
3	Analog In-
4	GND
5	GND
6	Analog In+
7	Do not connect
8	Do not connect
case	Shield

S5 BUS TERMINATION / ANIN2 PULL DOWN



S5

Switch	E1200
S5	Switch 1: AnIn2 Pulldown (4k7 Pulldown on X4.4). Set to ON, if X4.4 is used as digital Output. Switch 2: Termination Resistor for RS485 on CMD (120R between pin 1 and 2 on X7/X8) on/off Switch 3: CAN Termination on CMD (120R between pin 7 and 8 on X7/X8) on/off Switch 4: CAN Termination on ME (120R between pin 7 and 8 on X10/X11) on/off Factory settings: all switches "off"

LEDS STATE DISPLAY



24VOK	Green	24V Logic Supply OK
EN	Yellow	Motor Enabled / Error Code Low Nibble
Warn	Yellow	Warning / Error Code High Nibble
Error	Red	Error

RT BUS LEDS



BUS OK	Green	OK
BUS Error	Red	Error

The use of these LEDs depends on the type of fieldbus which is used. Please see the corresponding manual for further information.

S1-2 ADDRESS SELECTORS / BUS TERMINATION

E12x0 V1



S1



S2

Switch	
S1	Bus ID High (0...F). Bit 5 is LSB, bit 8 MSB
S2	Bus ID Low(0...F). Bit 1 is LSB, bit 4 MSB

The use of these switches depends on the type of fieldbus which is used. Please see the corresponding manual for further information.

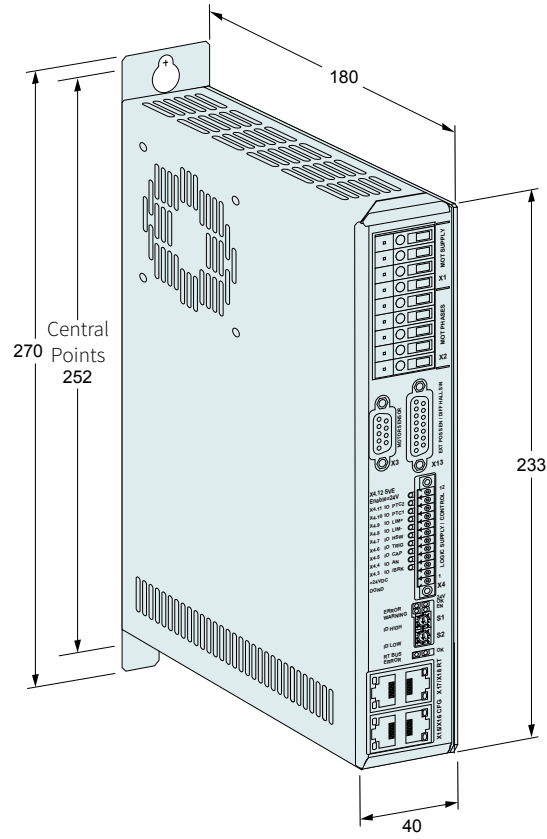

Dimensions in mm

Servo Drive Series		E1200
Width	mm (in)	40 (1.6)
Height	mm (in)	270 (10.6)
Height without fixings	mm (in)	233 (9.2)
Depth	mm (in)	180 (7.1)
Weight	kg (lb)	1.5 (3.3)
Case IP Code	IP	20
Mounting screws	mm (in)	2 x M5
Mounting distance	mm (in)	252 (9.92)
Storage temperature	°C	-25...40
Transport temperature	°C	-25...70
Operating temperature	°C	0...40 at rated date 40...50 with power derating
Relative humidity		95% (non-condensing)
Max. case temperature	°C	65
Max. power dissipation	W	30
Distance between Drives	mm (in)	20 (0.8) left/right 50 (2) top/bottom

Servo Drives		
Item	Description	Part Number
E1250-PL-UC	POWERLINK Servo Drive 72VDC/32A	0150-1760
E1250-PN-UC	PROFINET Servo Drive 72VDC/32A	0150-1762
E1250-PD-UC	ProfiDrive Servo Drive 72VDC/32A	0150-2620
E1250-EC-UC	EtherCAT Servo Drive 72VDC/32A	0150-1763
E1250-SE-UC	sercos over EtherCAT Servo Drive 72VDC/32A	0150-1898
E1250-DS-UC	EtherCAT CoE Servo Drive 72VDC/32A	0150-2410
E1250-SC-UC	sercos Servo Drive 72VDC/32A	0150-1764
E1250-IP-UC	ETHERNET IP Servo Drive 72VDC/32A	0150-1761
E1250-LU-UC	LinUDP Servo Drive 72VDC/32A	0150-2493
E1230-DP-UC	PROFIBUS-DP Servo Drive 72VDC/32A	0150-1766
E1200-GP-UC	GENERAL PURPOSE Servo Drive 72VDC/32A	0150-1771

Accessories		
Item	Description	Part Number
Connector for X4	Connector MC 1,5/12-STF-3,5, delivered with drive	0150-3300