

SRZ Screw Rail® Linear Actuators

- Coaxial Screw and Rail Guides
- Continuous Self-Adjusting Anti-Backlash

Traditionally, linear motion has required separate components to handle drive, support and guidance. The compact Screw Rail combines all functions in a single, coaxial component.

By eliminating the need for external rail-to-screw alignment, the Screw Rail simplifies the design, manufacture and assembly of motion systems. The coaxial design saves as much as 80% of the space used by a two-rail system and is generally less expensive than the equivalent components purchased separately. An added benefit is the ability to get three-dimensional motion from a single Screw Rail.



SRZ
Anti-Backlash
Screw Rail Linear Actuator

Identifying SRZ Screw Rail Part Numbers when Ordering

SR	Z	06	K	A	0100	XXX
Prefix SR = Screw Rail	Nut Style A = Anti-Backlash	Nominal Rail Diam. 03 = 3/8-in (10 mm) 04* = 1/2-in (13 mm) 06* = 3/4-in (19 mm) 08* = 1-in (25 mm)	Coating S = Uncoated K = Kerkote®	Drive / Mounting A = None	Nominal Thread Lead Code 0050 = .05 -in (1.27) SRZ03, SRZ04 0100 = .100-in (2.54) SRZ03, SRZ06, SRZ08 0200 = .200-in (5.08) SRZ06, SRZ08 0250 = .250-in (6.35) SRZ03, SRZ04 0375 = .375-in (9.53) SRZ03 0500 = .500-in (12.70) SRZ04, SRZ06, SRZ08 1000 = 1.00-in (25.4) SRZ04, SRZ06, SRZ08	Unique Identifier Suffix used to identify specific motors or a proprietary suffix assigned to a specific customer application. The identifier can apply to either a standard or custom part.

NOTE: Dashes must be included in Part Number (-) as shown above. For assistance call our Engineering Team at 603 213 6290. Right-hand and left-hand assemblies available.

Dimensional Drawings

Assembly Option

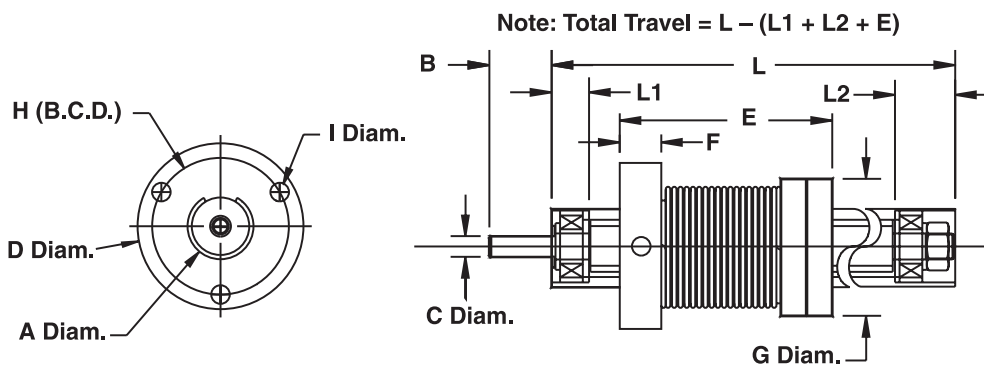

When mounted vertically, the Screw Rail can be used to simultaneously lift and rotate (Z-theta motion). With one motor driving the screw and a second rotating the rail, a compact, self-supporting pick and place mechanism can be created.

Part No.		A Diam.	B	C Diam.	D Diam.	E	F	G Diam.	H (B, C, D)	I	L1	L2
SRZ03	inch	.364/.367	.38	.1245/.1250	.98	1.1	.28	.73	.75	.094	.37	.38
	mm	9.24/9.32	9.56	3.16/3.18	24.9	27.94	7.2	18.5	19.1	*	9.4	9.66
SRZ04	inch	.489/.492	0.62	.1870/.1875	1.31	1.4	.38	.97	1.03	0.140	0.26	0.36
	mm	12.42/12.5	15.75	4.75/4.76	33.3	36	9.5	24.7	26.2	*	6.6	9.1
SRZ06	inch	.739/.742	0.75	.2490/.2495	1.81	2.0	.50	1.38	1.48	0.173	0.38	0.70
	mm	18.77/18.85	19.05	6.33/6.34	46.0	51	12.7	35.1	37.6	*	9.7	17.8
SRZ08	inch	.989/.992	0.75	.2490/.2495	2.30	2.5	.63	1.72	1.92	0.200	0.48	0.77
	mm	25.12/25.2	19.05	6.33/6.34	58.4	64	15.9	43.7	48.8	*	12.2	19.6

*Metric available as requested.

Part No.	Inch Lead**		Thread Lead Code	Nominal Rail Diam.		Nominal Screw Diam.		Max Drag Torque		Life @ 1/4 Design Load x 10 ⁶ (Non Anti-Backlash)		Torque-to-Move Lead		Design Load		Screw inertia per Unit Length		Equivalent Diam*	
	inch	mm		inch	mm	inch	mm	oz-in	NM	inch	cm	oz-in/lb	NM/Kg	lbs	NM	oz-in sec ² /in	KgM ² /M	inch	mm
SRZ03	.050	1.27	0050	3/8	10	3/16	5	2.0	0.014	50 to 80	130 to 200	0.5	0.007	10	50	.1 x 10 ⁻⁵	.4 x 10 ⁻⁶	.30	7.6
	.100	2.54	0100					2.5	0.018			1.0	0.016						
	.250	6.35	0250					3.0	0.020			1.25	0.019						
	.375	9.53	0375					3.5	0.025			2.0	0.030						
SRZ04	.050	1.27	0050	1/2	13	1/4	6	3.0	0.020	75 to 100	190 to 250	0.5	0.007	25	10	.3 x 10 ⁻⁵	1.3 x 10 ⁻⁶	.39	9.9
	.250	6.35	0250					4.0	0.030			1.5	0.023						
	.500	12.7	0500					5.0	0.040			2.5	0.039						
	1.00	25.40	1000					6.0	0.045			4.5	.070						
SRZ06	.100	2.54	0100	3/4	19	3/8	10	6.0	0.045	90 to 140	230 to 350	1.0	0.016	50	20	1.5 x 10 ⁻⁵	6.5 x 10 ⁻⁶	.60	15.2
	.200	5.08	0200					6.5	0.047			1.5	0.023						
	.500	12.7	0500					7.0	0.050			2.5	0.039						
	1.00	25.40	1000					7.5	0.053			4.5	0.070						
SRZ08	.100	2.54	0100	1	25	1/2	13	8.0	0.057	120 to 160	350 to 410	1.0	0.016	100	45	5.2 x 10 ⁻⁵	20.0 x 10 ⁻⁶	.81	20.5
	.200	5.08	0200					8.5	0.060			1.5	0.023						
	.500	12.7	0500					9.0	0.064			2.5	0.039						
	1.00	25.40	1000					9.5	0.067			4.5	0.070						

*Screw Rail stiffness may be modeled using Classical Beam Deflection Theory with equivalent stainless steel beam of diameter given.

**Other leads available as custom orders.