

LINEAR MOTORS P10-70x240U



- ✓ 3 x 400VAC Technology
- ✓ Peak forces up to 1650 N
- ✓ Extremely high dynamic
- ✓ Separate connector for sensor and power cable
- ✓ Can also be controlled by standard third-party servo drives

LINEAR MOTORS P10-70x240U

Technical Data	545
Motor Specifications	
P10-70x240U/10	550
P10-70x240U/110	551
P10-70x240U/210	552
P10-70x240U/310	553
P10-70x240U/410	554
P10-70x240U/510	555
P10-70x240U/610	556
P10-70x240U/810	557
P10-70x240U/1010	558
P10-70x240U/1210	559
P10-70x240U/1410	560
P10-70x240U/1610	561
Linear Guides	562
Accessories	564



MOTOR FAMILY P10-70x240U

Technical Data			
Stroke			
Max. Stroke (ES)	mm (in)		1610 (63.39)
Force			
Max. Force @ 1x230VAC	N (lbf)		1650 (371)
Max. Force @ 3x400VAC	N (lbf)		1650 (371)
Max. Cont. Force [Passive cooling/ Fan / Fluid]	N (lbf)		190 / 290 / 510 (43 / 66 / 120)
Max. Border Force relative	%		100
Force Constant 1	N/A _{pk} (lbf/A _{pk})		59 (13.3)
Force Constant 2	N/A _{rms} (lbf/A _{rms})		83.4 (18.8)
Velocity			
Max. Velocity @ 1x230VAC	m/s (in/s)		3 (119.9)
Max. Velocity @ 3x400VAC	m/s (in/s)		5.4 (209.9)
Position Detection			
Position Resolution	mm (in)		0.005 (0.0002)
Repeatability	mm (in)		±0.05 (±0.002)
Position Resolution with ES	mm (in)		0.001 (0.00004)
Repeatability with ES	mm (in)		±0.01 (±0.0004)
Linearity with ES	mm (in)		±0.01 (±0.0004)
Electrical Data			
Max. Current @ 1x230VAC	A _{pk} / A _{rms}		27.9 / 19.7
Max. Current @ 3x400VAC	A _{pk} / A _{rms}		27.9 / 19.7
Max. Cont. Current 1 [Passive cooling / Fan / Fluid]	A _{pk}		3.3 / 5 / 8.7
Max. Cont. Current 2 [Passive cooling / Fan / Fluid]	A _{rms}		2.3 / 3.5 / 6.1
Back EMF Constant	V _{pk} / (m/s) V _{pk} / (in/s)		68.1 (1.73)
Terminal Resistance 25 °C / 120 °C	Ohm		6.3 / 8.6
Terminal Inductivity	mH		12
Magnetic Period	mm (in)		40 (1.57)
Thermal Data			
Max. Winding Temperature (Sensor)	°C		90
Thermal Resistance [Passive cooling / Fan / Fluid]	°K/W		0.87 / 0.38 / 0.12
Thermal Time Constant [Passive cooling / Fan / Fluid]	s		2100 / 510 / 110
Mechanical Data			
Stator Diameter	mm (in)		70 (2.8)
Stator Length	mm (in)		340 (13)
Stator Mass	g (lb)		5550 (12.21)
Slider Diameter	mm (in)		28 (1.1)
Slider Length	mm (in)		390 - 1990 (15 - 78)
Slider Mass	g (lb)		1830 - 9350 (4.03 - 20.57)
IP Code			IP 65
Certification			
UL	File-No.		E354430

STATOR

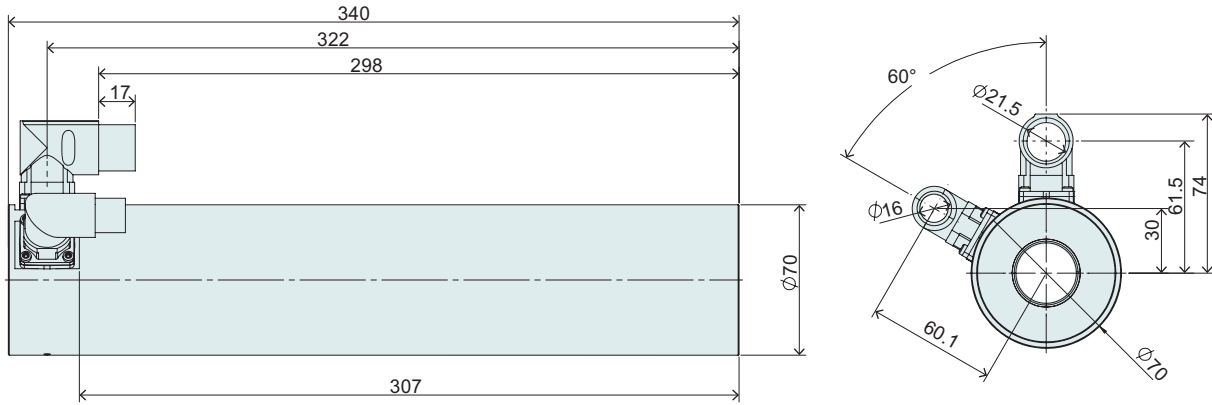

Item	Description	Item-No.
PS10-70x240U-BL-QJ	Stator 3x400VAC, LinMot Encoder	0150-1293
PS10-70x240U-BL-QJ-D01	Stator 3x400VAC, Sin/Cos Encoder 1Vpp, KTY	0150-2284
PS10-70x240U-BL-QJ-D02	Stator 3x400VAC, Sin/Cos Encoder 1Vpp, PTC	0150-2362
PS10-70x240U-BL-QJ-D03	Stator 3x400VAC, Sin/Cos 1Vpp, KTY on power connector	0150-2710

CONNECTOR PS10-70x240U-BL-QJ

Motor Connector Wiring	Connector Encoder J	Wire Color Motor Cable	
+5 VDC	Supply	1	red
GND	Supply	2	black
Sense +5V	Supply Sense	3	white
Sense GND	Supply Sense	4	brown
Mot. Link C+	Communication	5	pink
Mot. Link C-	Communication	6	grey
Sin+	Encoder	7	yellow
Sin-	Encoder	8	orange
Cos+	Encoder	9	green
Cos-	Encoder	10	blue
n. c.	n. c.	11	n. c.
n. c.	n. c.	12	n. c.
n. c.	n. c.	13	n. c.
n. c.	n. c.	14	n. c.
n. c.	n. c.	15	n. c.
n. c.	n. c.	16	n. c.
n. c.	n. c.	17	n. c.

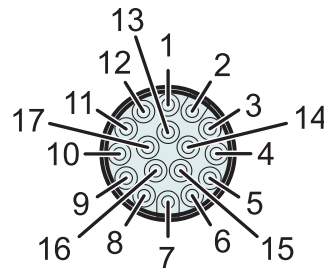

Connector Encoder J

View: Motor connector, plug side

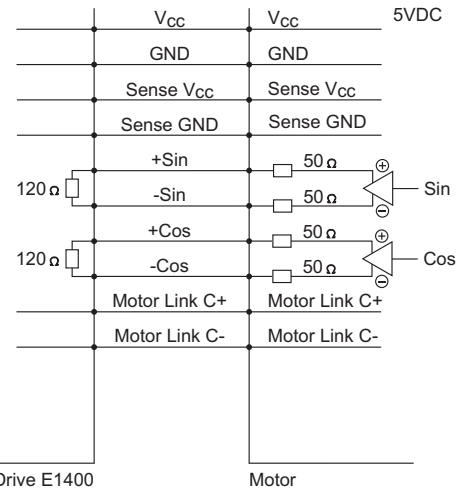

LinMot Drive E1400

Motor

Motor Connector Wiring	Connector Power Q	Wire Color Motor Cable
Phase U	1	red
PE	2	yellow-green
Phase W	3	green
Phase V	4	blue
n. c.	A	n. c.
n. c.	B	n. c.
n. c.	C	n. c.
n. c.	D	n. c.

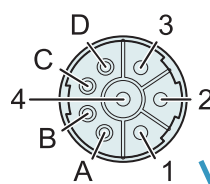

Connector Power Q

View: Motor connector, plug side

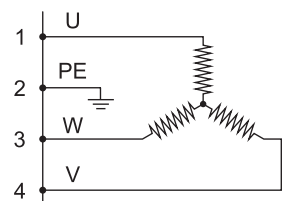

CONNECTOR PS10-70x240U-BL-QJ-D01/02

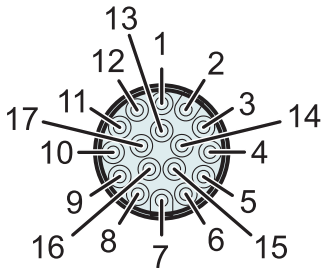

Connector Encoder J

View: Motor connector, plug side

3 ... 13VDC
($I_{max} < 150\text{mA}$ @ 5VDC)
($I_{max} < 80\text{mA}$ @ 12VDC)

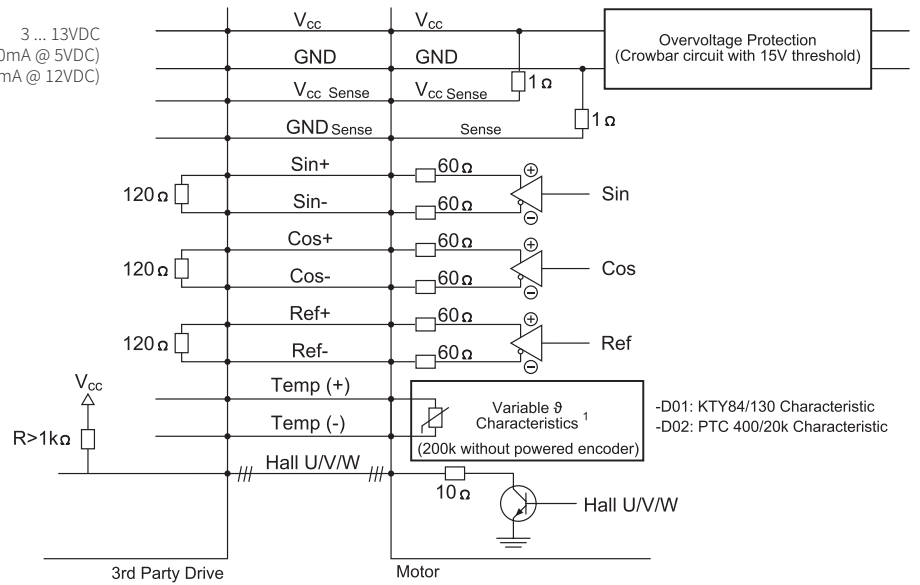

-D01: KTY84/130 Characteristic
-D02: PTC 400/20k Characteristic

Motor Connector Wiring				
PS10-70x240U-BL-QJ-D01	PS10-70x240U-BL-QJ-D02	Function	Connector Encoder J	Wire Color Motor Cable
3 ... 13 VDC	3 ... 13 VDC	Supply	1	Motor Cable
GND	GND	Supply	2	brown
Vcc Sense (optional)	Vcc Sense (optional)	Supply Sense	3	green
GND Sense (optional)	GND Sense (optional)	Supply Sense	4	yellow
Do not connect	Do not connect	-	5	-
Do not connect	Do not connect	-	6	-
Sin+	Sin+	Encoder 1 Vpp	7	grey
Sin-	Sin-	Encoder 1 Vpp	8	pink
Cos+	Cos+	Encoder 1 Vpp	9	blue
Cos-	Cos-	Encoder 1 Vpp	10	red
Ref+	Ref+	Encoder 1 Vpp	11	black
Ref-	Ref-	Encoder 1 Vpp	12	violett
Hall U	Hall U	Encoder (open collector)	13	grey-red
Hall V	Hall V	Encoder (open collector)	14	red-blue
Hall W	Hall W	Encoder (open collector)	15	white-green
Temp+ (KTY84/130 Char.)	Temp+ (PTC 400/20k Char.)	Temperature ¹	16	yellow-brown
Temp- (KTY84/130 Char.)	Temp- (PTC 400/20k Char.)	Temperature ¹	17	white-yellow

1) The temperature evaluation circuit must be powered from the encoder supply and must be at the same potential. The grounds of the temperature evaluation circuit and the encoder have to be connected. The encoder must have been powered on for at least 50 ms, before valid temperatures can be measured. If the encoder is powered off, 200k Ohms are measured between Pins 16 and 17. The maximum voltage between Pin 16 and 17 must not exceed 16 VDC. The maximum current must not exceed 15 mA.

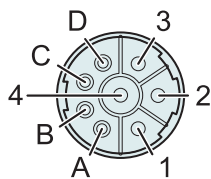

Connector Power Q

View: Motor connector, plug side

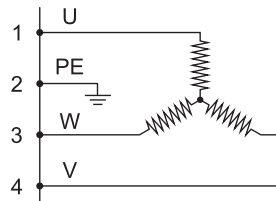

Motor Connector Wiring			
PS10-70x240U-BL-QJ-D01	PS10-70x240U-BL-QJ-D02	Connector Power Q	Wire Color Motor Cable
Phase U	Phase U	1	red
PE	PE	2	yellow-green
Phase W	Phase W	3	green
Phase V	Phase V	4	blue
n. c.	n. c.	A	n. c.
n. c.	n. c.	B	n. c.
n. c.	n. c.	C	n. c.
n. c.	n. c.	D	n. c.

CONNECTOR PS10-70x240U-BL-QJ-D03

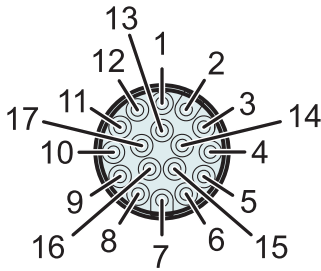

Connector Encoder J

View: Motor connector, plug side

3 ... 13VDC
($I_{max} < 150\text{mA}$ @ 5VDC)
($I_{max} < 80\text{mA}$ @ 12VDC)

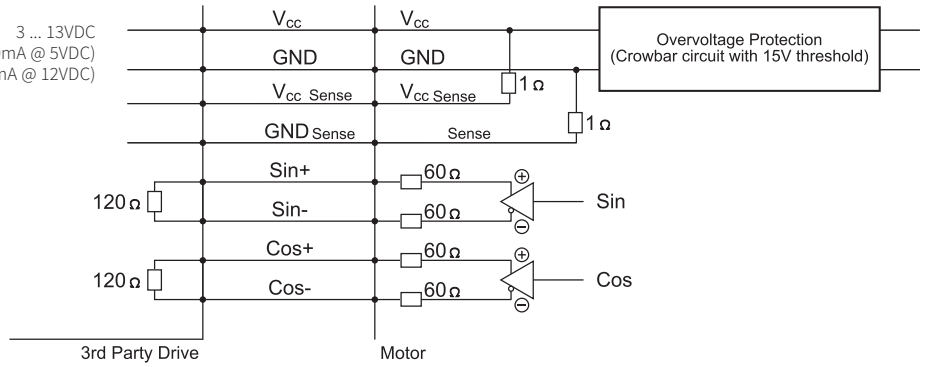

Motor Connector Wiring		Connector Encoder J	Wire Color Motor Cable
3 ... 13 VDC	Supply	1	red
GND	Supply	2	black
Vcc Sense (optional)	Supply Sense	3	white
GND Sense (optional)	Supply Sense	4	brown
Do not connect	-	5	-
Do not connect	-	6	-
Sin+	Encoder 1 Vpp	7	yellow
Sin-	Encoder 1 Vpp	8	orange
Cos+	Encoder 1 Vpp	9	green
Cos-	Encoder 1 Vpp	10	blue
n. c.	-	11	n. c.
n. c.	-	12	n. c.
n. c.	-	13	n. c.
Do not connect	-	14	n. c.
n. c.	-	15	n. c.
n. c.	-	16	n. c.
n. c.	-	17	n. c.

Connector Power Q

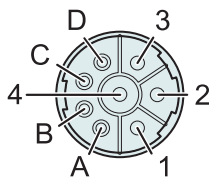

View: Motor connector, plug side

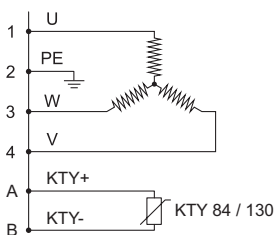

Motor Connector Wiring	Connector Power Q	Wire Color Motor Cable
Phase U	1	red (previously: black 1)
PE	2	yellow-green
Phase W	3	green (previously: black 3)
Phase V	4	blue (previously: black 2)
KTY +	A	purple (previously: black 5)
KTY -	B	grey (previously: black 6)
n. c.	C	yellow (previously: black 7)
n. c.	D	brown (previously: black 8)

SLIDER

Slider Standard

Number of grooves determines the slider type (see chapter 2 / slider) and marks the front end.

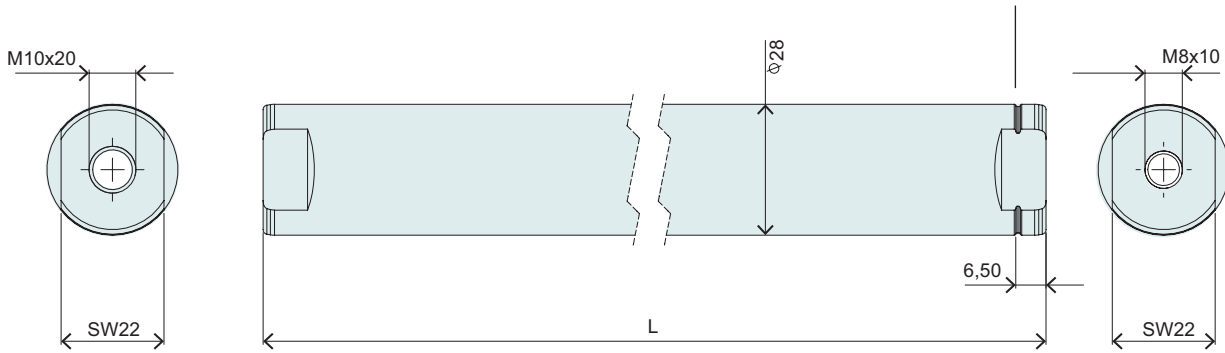

Slider Standard			
Item	Description	Max. Stroke [mm]	Item-No.
PL10-28x390/340	Slider for P10-70 'standard'	10	0150-2194
PL10-28x490/440	Slider for P10-70 'standard'	110	0150-2195
PL10-28x590/540	Slider for P10-70 'standard'	210	0150-2196
PL10-28x690/640	Slider for P10-70 'standard'	310	0150-2197
PL10-28x790/740	Slider for P10-70 'standard'	410	0150-2198
PL10-28x890/840	Slider for P10-70 'standard'	510	0150-2199
PL10-28x990/940	Slider for P10-70 'standard'	610	0150-2203
PL10-28x1190/1140	Slider for P10-70 'standard'	810	0150-2204
PL10-28x1390/1340	Slider for P10-70 'standard'	1010	0150-2205
PL10-28x1590/1540	Slider for P10-70 'standard'	1210	0150-2206
PL10-28x1790/1740	Slider for P10-70 'standard'	1410	0150-2207
PL10-28x1990/1940	Slider for P10-70 'standard'	1610	0150-2208

P10-70x240U/10-BL-QJ

Max. Stroke: 10 mm
Peak Force: 1650 N

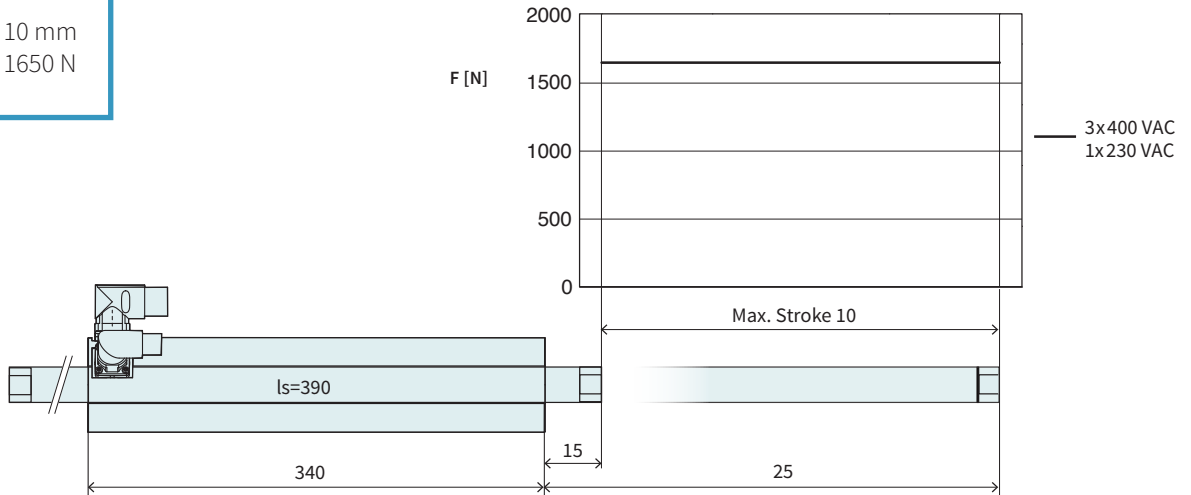

Dimensions in mm

Technical Data P10-70x240U/10

Technical Data P10-70x240U/10			
Stroke			
Max. Stroke	mm (in)		10 (0.39)
Force			
Max. Force @ 1x230VAC	N (lbf)		1650 (371)
Max. Force @ 3x400VAC	N (lbf)		1650 (371)
Max. Cont. Force [Passive cooling / Fan / Fluid]	N (lbf)		190 / 290 / 510 (43 / 66 / 120)
Max. Border Force relative	%		100
Force Constant 1	N/A _{pk} (lbf/A _{pk})		59 (13.3)
Force Constant 2	N/A _{rms} (lbf/A _{rms})		83.4 (18.8)
Velocity			
Max. Velocity @ 1x230VAC	m/s (in/s)		3 (119.9)
Max. Velocity @ 3x400VAC	m/s (in/s)		5.4 (5.4)
Position Detection			
Repeatability	mm (in)		±0.05 (±0.002)
Linearity	%		± 5.1
Electrical Data			
Max. Current @ 1x230VAC	A _{pk} / A _{rms}		27.9 / 19.7
Max. Current @ 3x400VAC	A _{pk} / A _{rms}		27.9 / 19.7
Max. Cont. Current 1 [Passive cooling / Fan / Fluid]	A _{pk}		3.3 / 5 / 8.7
Max. Cont. Current 2 [Passive cooling / Fan / Fluid]	A _{rms}		2.3 / 3.5 / 6.1
Thermal Data			
Max. Winding Temperature (Sensor)	°C		90
Thermal Resistance [Passive cooling / Fan / Fluid]	°K/W		0.87 / 0.38 / 0.12
Thermal Time Constant [Passive cooling / Fan / Fluid]	s		2100 / 510 / 110
Mechanical Data			
Slider Length	mm (in)		390 (15)
Slider Mass	g (lb)		1830 (4.03)



Item	Description	Item-No.
PS10-70x240U-BL-QJ	Stator 3x400VAC, LinMot Encoder	0150-1293
PS10-70x240U-BL-QJ-D01	Stator 3x400VAC, Sin/Cos Encoder 1Vpp, KTY	0150-2284
PS10-70x240U-BL-QJ-D02	Stator 3x400VAC, Sin/Cos Encoder 1Vpp, PTC	0150-2362
PS10-70x240U-BL-QJ-D03	Stator 3x400VAC, Sin/Cos 1Vpp, KTY on power connector	0150-2710
PL10-28x390/340	Slider for P10-70 'standard'	0150-2194

P10-70x240U/110-BL-QJ

Max. Stroke: 110 mm
Peak Force: 1650 N

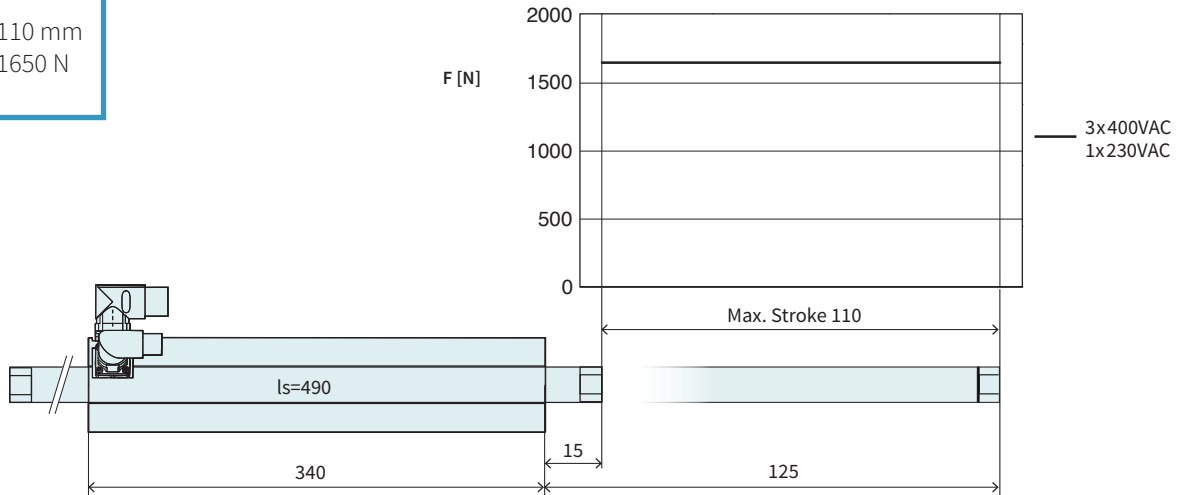

Dimensions in mm

Technical Data P10-70x240U/110			
Stroke			
Max. Stroke	mm (in)		110 (4.32)
Force			
Max. Force @ 1x230VAC	N (lbf)		1650 (371)
Max. Force @ 3x400VAC	N (lbf)		1650 (371)
Max. Cont. Force [Passive cooling / Fan / Fluid]	N (lbf)		190 / 290 / 510 (43 / 66 / 120)
Max. Border Force relative	%		100
Force Constant 1	N/A _{pk} (lbf/A _{pk})		59 (13.3)
Force Constant 2	N/A _{rms} (lbf/A _{rms})		83.4 (18.8)
Velocity			
Max. Velocity @ 1x230VAC	m/s (in/s)		3 (119.9)
Max. Velocity @ 3x400VAC	m/s (in/s)		5.4 (5.4)
Position Detection			
Repeatability	mm (in)		±0.05 (±0.002)
Linearity	%		± 0.55
Electrical Data			
Max. Current @ 1x230VAC	A _{pk} / A _{rms}		27.9 / 19.7
Max. Current @ 3x400VAC	A _{pk} / A _{rms}		27.9 / 19.7
Max. Cont. Current 1 [Passive cooling / Fan / Fluid]	A _{pk}		3.3 / 5 / 8.7
Max. Cont. Current 2 [Passive cooling / Fan / Fluid]	A _{rms}		2.3 / 3.5 / 6.1
Thermal Data			
Max. Winding Temperature (Sensor)	°C		90
Thermal Resistance [Passive cooling / Fan / Fluid]	°K/W		0.87 / 0.38 / 0.12
Thermal Time Constant [Passive cooling / Fan / Fluid]	s		2100 / 510 / 110
Mechanical Data			
Slider Length	mm (in)		490 (19)
Slider Mass	g (lb)		2300 (5.06)



Item	Description	Item-No.
PS10-70x240U-BL-QJ	Stator 3x400VAC, LinMot Encoder	0150-1293
PS10-70x240U-BL-QJ-D01	Stator 3x400VAC, Sin/Cos Encoder 1Vpp, KTY	0150-2284
PS10-70x240U-BL-QJ-D02	Stator 3x400VAC, Sin/Cos Encoder 1Vpp, PTC	0150-2362
PS10-70x240U-BL-QJ-D03	Stator 3x400VAC, Sin/Cos 1Vpp, KTY on power connector	0150-2710
PL10-28x490/440	Slider for P10-70 'standard'	0150-2195

P10-70x240U/210-BL-QJ

Max. Stroke: 210 mm
Peak Force: 1650 N

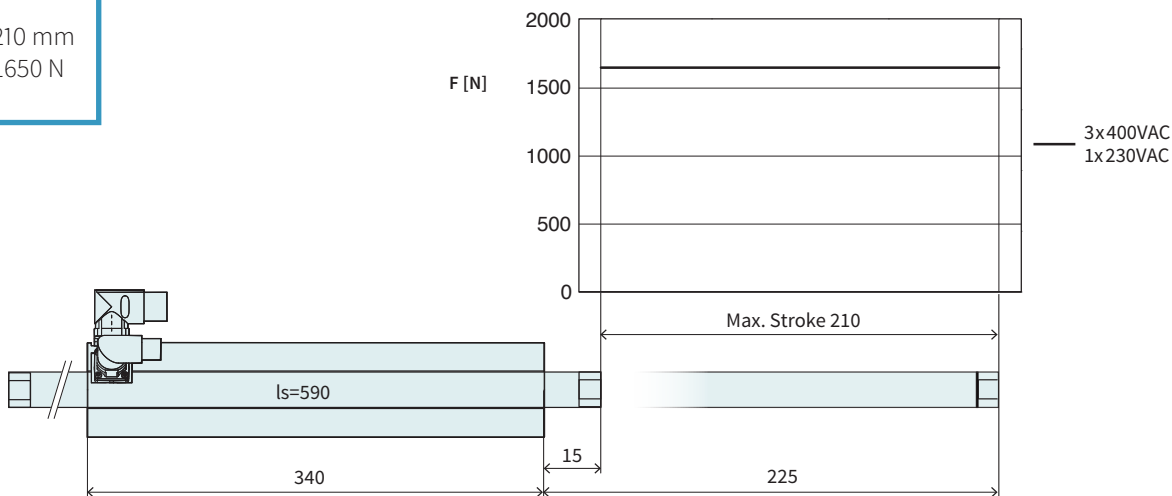

Dimensions in mm

Technical Data P10-70x240U/210

Technical Data P10-70x240U/210				
Stroke				
Max. Stroke	mm	(in)	210	(8.26)
Force				
Max. Force @ 1x230VAC	N	(lbf)	1650	(371)
Max. Force @ 3x400VAC	N	(lbf)	1650	(371)
Max. Cont. Force [Passive cooling / Fan / Fluid]	N	(lbf)	190 / 290 / 510	(43 / 66 / 120)
Max. Border Force relative	%		100	
Force Constant 1	N/A _{pk}	(lbf/A _{pk})	59	(13.3)
Force Constant 2	N/A _{rms}	(lbf/A _{rms})	83.4	(18.8)
Velocity				
Max. Velocity @ 1x230VAC	m/s	(in/s)	3	(119.9)
Max. Velocity @ 3x400VAC	m/s	(in/s)	5.4	(5.4)
Position Detection				
Repeatability	mm	(in)	±0.05	(±0.002)
Linearity	%		± 0.35	
Electrical Data				
Max. Current @ 1x230VAC	A _{pk} / A _{rms}		27.9 / 19.7	
Max. Current @ 3x400VAC	A _{pk} / A _{rms}		27.9 / 19.7	
Max. Cont. Current 1 [Passive cooling / Fan / Fluid]	A _{pk}		3.3 / 5 / 8.7	
Max. Cont. Current 2 [Passive cooling / Fan / Fluid]	A _{rms}		2.3 / 3.5 / 6.1	
Thermal Data				
Max. Winding Temperature (Sensor)	°C		90	
Thermal Resistance [Passive cooling / Fan / Fluid]	°K/W		0.87 / 0.38 / 0.12	
Thermal Time Constant [Passive cooling / Fan / Fluid]	s		2100 / 510 / 110	
Mechanical Data				
Slider Length	mm	(in)	590	(23)
Slider Mass	g	(lb)	2770	(6.09)

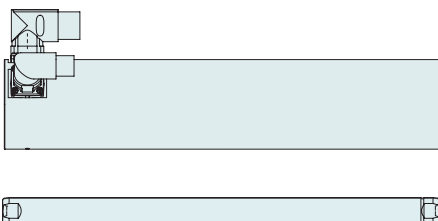

Item	Description	Item-No.
PS10-70x240U-BL-QJ	Stator 3x400VAC, LinMot Encoder	0150-1293
PS10-70x240U-BL-QJ-D01	Stator 3x400VAC, Sin/Cos Encoder 1Vpp, KTY	0150-2284
PS10-70x240U-BL-QJ-D02	Stator 3x400VAC, Sin/Cos Encoder 1Vpp, PTC	0150-2362
PS10-70x240U-BL-QJ-D03	Stator 3x400VAC, Sin/Cos 1Vpp, KTY on power connector	0150-2710
PL10-28x590/540	Slider for P10-70 'standard'	0150-2196

P10-70x240U/310-BL-QJ

Max. Stroke: 310 mm
Peak Force: 1650 N

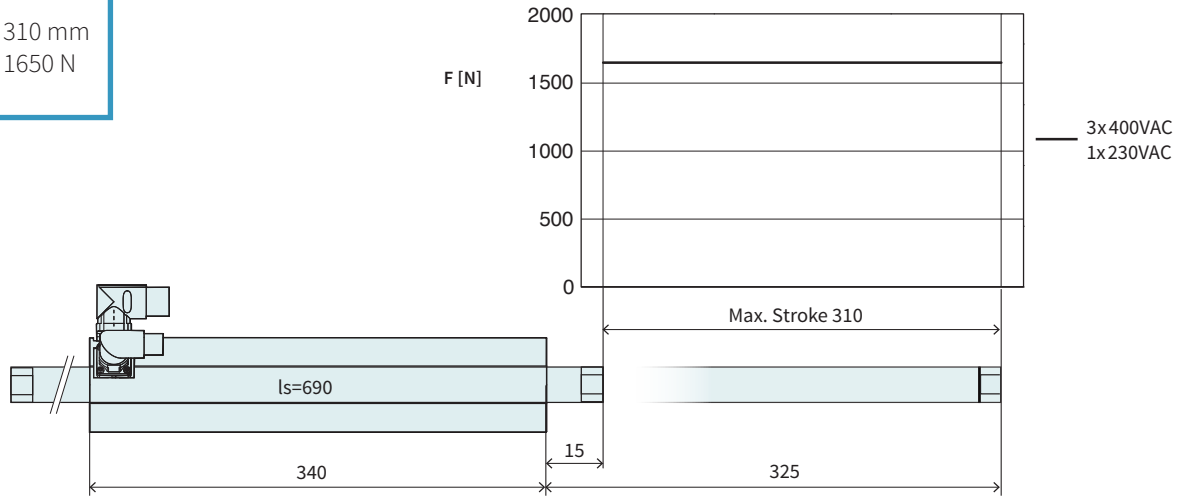

Dimensions in mm

Technical Data P10-70x240U/310			
Stroke			
Max. Stroke	mm (in)		310 (12.19)
Force			
Max. Force @ 1x230VAC	N (lbf)		1650 (371)
Max. Force @ 3x400VAC	N (lbf)		1650 (371)
Max. Cont. Force [Passive cooling / Fan / Fluid]	N (lbf)		190 / 290 / 510 (43 / 66 / 120)
Max. Border Force relative	%		100
Force Constant 1	N/A _{pk} (lbf/A _{pk})		59 (13.3)
Force Constant 2	N/A _{rms} (lbf/A _{rms})		83.4 (18.8)
Velocity			
Max. Velocity @ 1x230VAC	m/s (in/s)		3 (119.9)
Max. Velocity @ 3x400VAC	m/s (in/s)		5.4 (5.4)
Position Detection			
Repeatability	mm (in)		±0.05 (±0.002)
Linearity	%		±0.25
Electrical Data			
Max. Current @ 1x230VAC	A _{pk} / A _{rms}		27.9 / 19.7
Max. Current @ 3x400VAC	A _{pk} / A _{rms}		27.9 / 19.7
Max. Cont. Current 1 [Passive cooling / Fan / Fluid]	A _{pk}		3.3 / 5 / 8.7
Max. Cont. Current 2 [Passive cooling / Fan / Fluid]	A _{rms}		2.3 / 3.5 / 6.1
Thermal Data			
Max. Winding Temperature (Sensor)	°C		90
Thermal Resistance [Passive cooling / Fan / Fluid]	°K/W		0.87 / 0.38 / 0.12
Thermal Time Constant [Passive cooling / Fan / Fluid]	s		2100 / 510 / 110
Mechanical Data			
Slider Length	mm (in)		690 (27)
Slider Mass	g (lb)		3240 (7.13)



Item	Description	Item-No.
PS10-70x240U-BL-QJ	Stator 3x400VAC, LinMot Encoder	0150-1293
PS10-70x240U-BL-QJ-D01	Stator 3x400VAC, Sin/Cos Encoder 1Vpp, KTY	0150-2284
PS10-70x240U-BL-QJ-D02	Stator 3x400VAC, Sin/Cos Encoder 1Vpp, PTC	0150-2362
PS10-70x240U-BL-QJ-D03	Stator 3x400VAC, Sin/Cos 1Vpp, KTY on power connector	0150-2710
PL10-28x690/640	Slider for P10-70 'standard'	0150-2197

P10-70x240U/410-BL-QJ

Max. Stroke: 410 mm
Peak Force: 1650 N

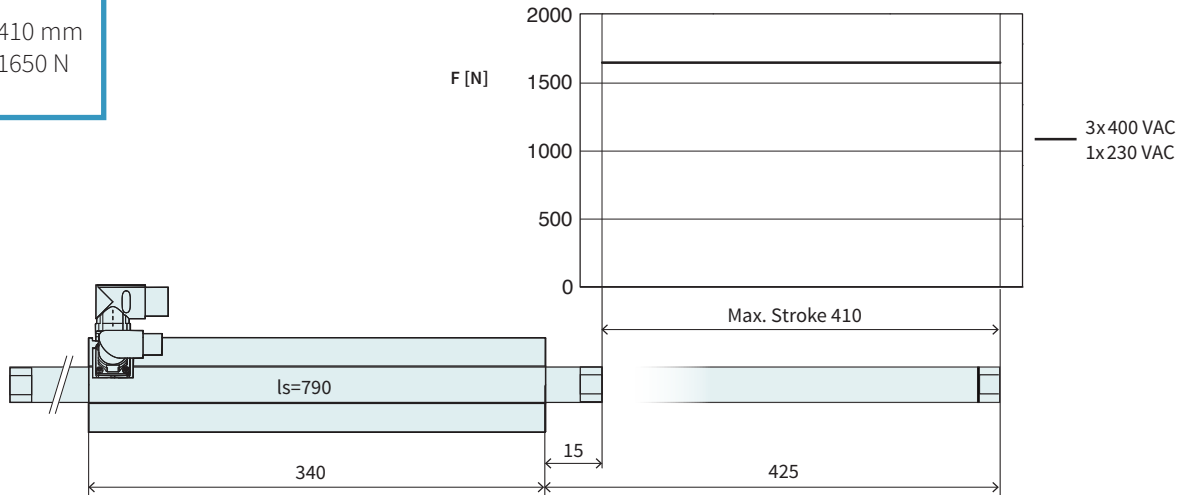

Dimensions in mm

Technical Data P10-70x240U/410

Technical Data P10-70x240U/410			
Stroke			
Max. Stroke	mm (in)	410	(16.1)
Force			
Max. Force @ 1x230VAC	N (lbf)	1650	(371)
Max. Force @ 3x400VAC	N (lbf)	1650	(371)
Max. Cont. Force [Passive cooling / Fan / Fluid]	N (lbf)	190 / 290 / 510	(43 / 66 / 120)
Max. Border Force relative	%	100	
Force Constant 1	N/A _{pk} (lbf/A _{pk})	59	(13.3)
Force Constant 2	N/A _{rms} (lbf/A _{rms})	83.4	(18.8)
Velocity			
Max. Velocity @ 1x230VAC	m/s (in/s)	3	(119.9)
Max. Velocity @ 3x400VAC	m/s (in/s)	5.4	(5.4)
Position Detection			
Repeatability	mm (in)	±0.05	(±0.002)
Linearity	%	± 0.2	
Electrical Data			
Max. Current @ 1x230VAC	A _{pk} / A _{rms}	27.9 / 19.7	
Max. Current @ 3x400VAC	A _{pk} / A _{rms}	27.9 / 19.7	
Max. Cont. Current 1 [Passive cooling / Fan / Fluid]	A _{pk}	3.3 / 5 / 8.7	
Max. Cont. Current 2 [Passive cooling / Fan / Fluid]	A _{rms}	2.3 / 3.5 / 6.1	
Thermal Data			
Max. Winding Temperature (Sensor)	°C	90	
Thermal Resistance [Passive cooling / Fan / Fluid]	°K/W	0.87 / 0.38 / 0.12	
Thermal Time Constant [Passive cooling / Fan / Fluid]	s	2100 / 510 / 110	
Mechanical Data			
Slider Length	mm (in)	790	(31)
Slider Mass	g (lb)	3710	(8.16)



Item	Description	Item-No.
PS10-70x240U-BL-QJ	Stator 3x400VAC, LinMot Encoder	0150-1293
PS10-70x240U-BL-QJ-D01	Stator 3x400VAC, Sin/Cos Encoder 1Vpp, KTY	0150-2284
PS10-70x240U-BL-QJ-D02	Stator 3x400VAC, Sin/Cos Encoder 1Vpp, PTC	0150-2362
PS10-70x240U-BL-QJ-D03	Stator 3x400VAC, Sin/Cos 1Vpp, KTY on power connector	0150-2710
PL10-28x790/740	Slider for P10-70 'standard'	0150-2198

P10-70x240U/510-BL-QJ

Max. Stroke: 510 mm
Peak Force: 1650 N

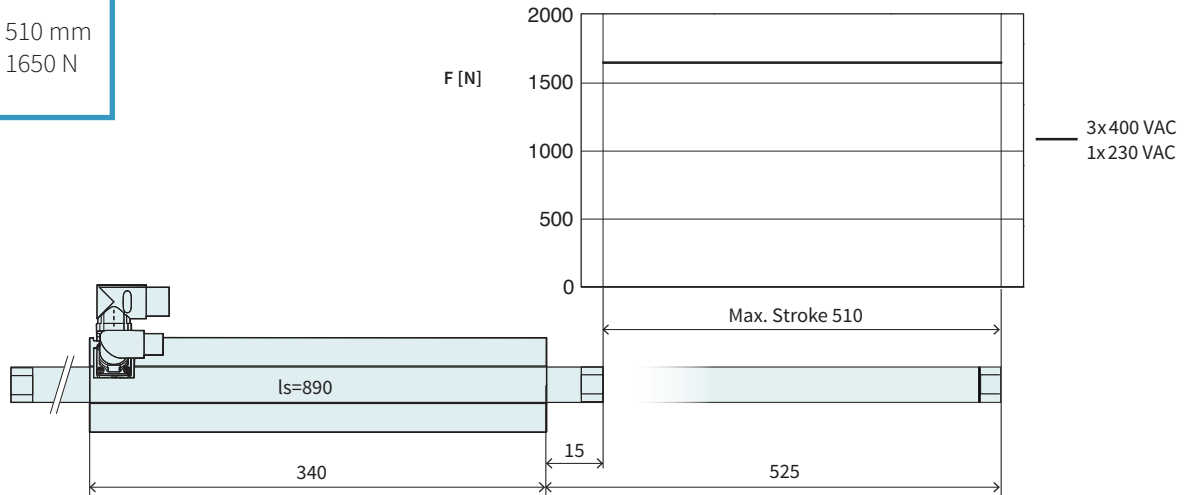

Dimensions in mm

Technical Data P10-70x240U/510			
Stroke			
Max. Stroke	mm (in)	510 (20.1)	
Force			
Max. Force @ 1x230VAC	N (lbf)	1650 (371)	
Max. Force @ 3x400VAC	N (lbf)	1650 (371)	
Max. Cont. Force [Passive cooling / Fan / Fluid]	N (lbf)	190 / 290 / 510 (43 / 66 / 120)	
Max. Border Force relative	%	100	
Force Constant 1	N/A _{pk} (lbf/A _{pk})	59 (13.3)	
Force Constant 2	N/A _{rms} (lbf/A _{rms})	83.4 (18.8)	
Velocity			
Max. Velocity @ 1x230VAC	m/s (in/s)	3 (119.9)	
Max. Velocity @ 3x400VAC	m/s (in/s)	5.4 (5.4)	
Position Detection			
Repeatability	mm (in)	±0.05 (±0.002)	
Linearity	%	± 0.2	
Electrical Data			
Max. Current @ 1x230VAC	A _{pk} / A _{rms}	27.9 / 19.7	
Max. Current @ 3x400VAC	A _{pk} / A _{rms}	27.9 / 19.7	
Max. Cont. Current 1 [Passive cooling / Fan / Fluid]	A _{pk}	3.3 / 5 / 8.7	
Max. Cont. Current 2 [Passive cooling / Fan / Fluid]	A _{rms}	2.3 / 3.5 / 6.1	
Thermal Data			
Max. Winding Temperature (Sensor)	°C	90	
Thermal Resistance [Passive cooling / Fan / Fluid]	°K/W	0.87 / 0.38 / 0.12	
Thermal Time Constant [Passive cooling / Fan / Fluid]	s	2100 / 510 / 110	
Mechanical Data			
Slider Length	mm (in)	890 (35)	
Slider Mass	g (lb)	4180 (9.2)	



Item	Description	Item-No.
PS10-70x240U-BL-QJ	Stator 3x400VAC, LinMot Encoder	0150-1293
PS10-70x240U-BL-QJ-D01	Stator 3x400VAC, Sin/Cos Encoder 1Vpp, KTY	0150-2284
PS10-70x240U-BL-QJ-D02	Stator 3x400VAC, Sin/Cos Encoder 1Vpp, PTC	0150-2362
PS10-70x240U-BL-QJ-D03	Stator 3x400VAC, Sin/Cos 1Vpp, KTY on power connector	0150-2710
PL10-28x890/840	Slider for P10-70 'standard'	0150-2199

P10-70x240U/610-BL-QJ

Max. Stroke: 610 mm
Peak Force: 1650 N

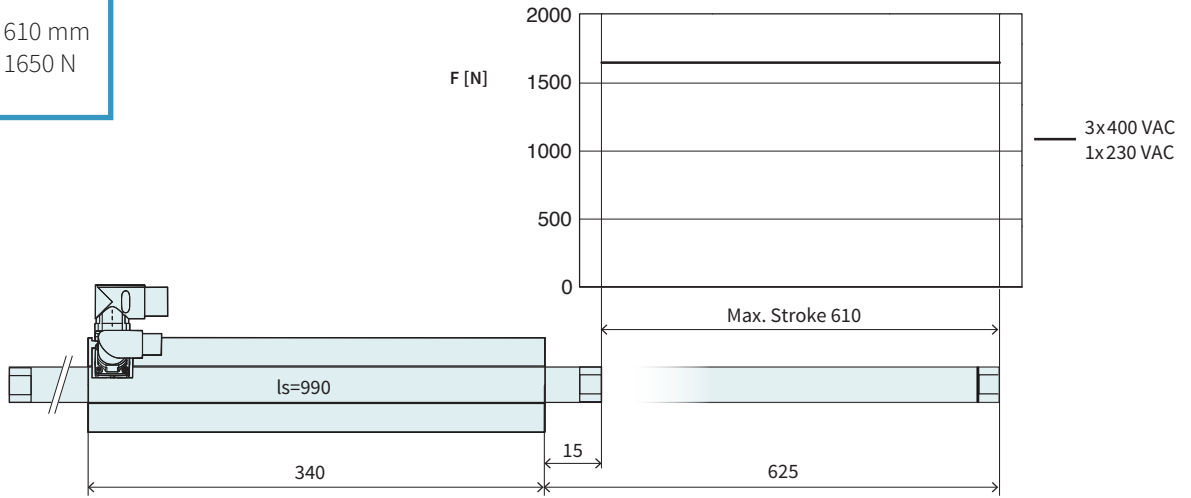

Dimensions in mm

Technical Data P10-70x240U/610

Technical Data P10-70x240U/610				
Stroke				
Max. Stroke	mm	(in)	610	(23.99)
Force				
Max. Force @ 1x230VAC	N	(lbf)	1650	(371)
Max. Force @ 3x400VAC	N	(lbf)	1650	(371)
Max. Cont. Force [Passive cooling / Fan / Fluid]	N	(lbf)	190 / 290 / 510	(43 / 66 / 120)
Max. Border Force relative	%		100	
Force Constant 1	N/A _{pk}	(lbf/A _{pk})	59	(13.3)
Force Constant 2	N/A _{rms}	(lbf/A _{rms})	83.4	(18.8)
Velocity				
Max. Velocity @ 1x230VAC	m/s	(in/s)	3	(119.9)
Max. Velocity @ 3x400VAC	m/s	(in/s)	5.4	(5.4)
Position Detection				
Repeatability	mm	(in)	±0.05	(±0.002)
Linearity	%		± 0.2	
Electrical Data				
Max. Current @ 1x230VAC	A _{pk} / A _{rms}		27.9 / 19.7	
Max. Current @ 3x400VAC	A _{pk} / A _{rms}		27.9 / 19.7	
Max. Cont. Current 1 [Passive cooling / Fan / Fluid]	A _{pk}		3.3 / 5 / 8.7	
Max. Cont. Current 2 [Passive cooling / Fan / Fluid]	A _{rms}		2.3 / 3.5 / 6.1	
Thermal Data				
Max. Winding Temperature (Sensor)	°C		90	
Thermal Resistance [Passive cooling / Fan / Fluid]	°K/W		0.87 / 0.38 / 0.12	
Thermal Time Constant [Passive cooling / Fan / Fluid]	s		2100 / 510 / 110	
Mechanical Data				
Slider Length	mm	(in)	990	(39)
Slider Mass	g	(lb)	4650	(10.23)

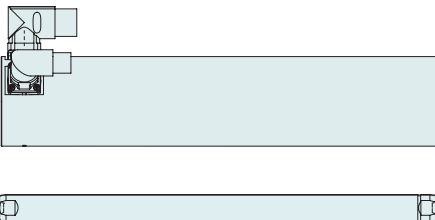

Item	Description	Item-No.
PS10-70x240U-BL-QJ	Stator 3x400VAC, LinMot Encoder	0150-1293
PS10-70x240U-BL-QJ-D01	Stator 3x400VAC, Sin/Cos Encoder 1Vpp, KTY	0150-2284
PS10-70x240U-BL-QJ-D02	Stator 3x400VAC, Sin/Cos Encoder 1Vpp, PTC	0150-2362
PS10-70x240U-BL-QJ-D03	Stator 3x400VAC, Sin/Cos 1Vpp, KTY on power connector	0150-2710
PL10-28x990/940	Slider for P10-70 'standard'	0150-2203

P10-70x240U/810-BL-QJ

Max. Stroke: 810 mm
Peak Force: 1650 N

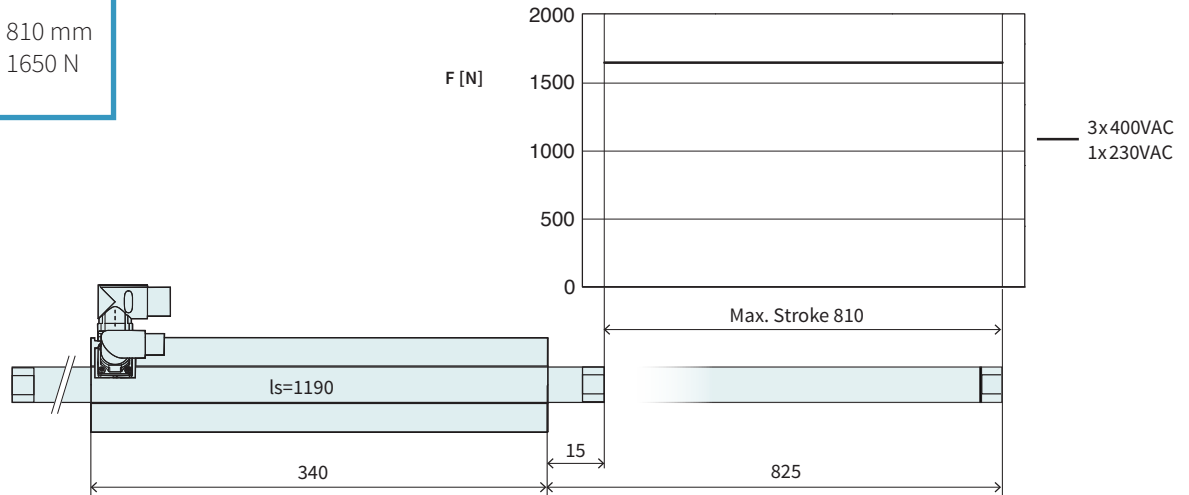

Dimensions in mm

Technical Data P10-70x240U/810			
Stroke			
Max. Stroke	mm (in)	810	(31.89)
Force			
Max. Force @ 1x230VAC	N (lbf)	1650	(371)
Max. Force @ 3x400VAC	N (lbf)	1650	(371)
Max. Cont. Force [Passive cooling / Fan / Fluid]	N (lbf)	190 / 290 / 510	(43 / 66 / 120)
Max. Border Force relative	%	100	
Force Constant 1	N/A _{pk} (lbf/A _{pk})	59	(13.3)
Force Constant 2	N/A _{rms} (lbf/A _{rms})	83.4	(18.8)
Velocity			
Max. Velocity @ 1x230VAC	m/s (in/s)	3	(119.9)
Max. Velocity @ 3x400VAC	m/s (in/s)	5.4	(5.4)
Position Detection			
Repeatability	mm (in)	±0.05	(±0.002)
Linearity	%	± 0.15	
Electrical Data			
Max. Current @ 1x230VAC	A _{pk} / A _{rms}	27.9 / 19.7	
Max. Current @ 3x400VAC	A _{pk} / A _{rms}	27.9 / 19.7	
Max. Cont. Current 1 [Passive cooling / Fan / Fluid]	A _{pk}	3.3 / 5 / 8.7	
Max. Cont. Current 2 [Passive cooling / Fan / Fluid]	A _{rms}	2.3 / 3.5 / 6.1	
Thermal Data			
Max. Winding Temperature (Sensor)	°C	90	
Thermal Resistance [Passive cooling / Fan / Fluid]	°K/W	0.87 / 0.38 / 0.12	
Thermal Time Constant [Passive cooling / Fan / Fluid]	s	2100 / 510 / 110	
Mechanical Data			
Slider Length	mm (in)	1190	(47)
Slider Mass	g (lb)	5590	(12.3)



Item	Description	Item-No.
PS10-70x240U-BL-QJ	Stator 3x400VAC, LinMot Encoder	0150-1293
PS10-70x240U-BL-QJ-D01	Stator 3x400VAC, Sin/Cos Encoder 1Vpp, KTY	0150-2284
PS10-70x240U-BL-QJ-D02	Stator 3x400VAC, Sin/Cos Encoder 1Vpp, PTC	0150-2362
PS10-70x240U-BL-QJ-D03	Stator 3x400VAC, Sin/Cos 1Vpp, KTY on power connector	0150-2710
PL10-28x1190/1140	Slider for P10-70 'standard'	0150-2204

P10-70x240U/1010-BL-QJ

Max. Stroke: 1010 mm
Peak Force: 1650 N

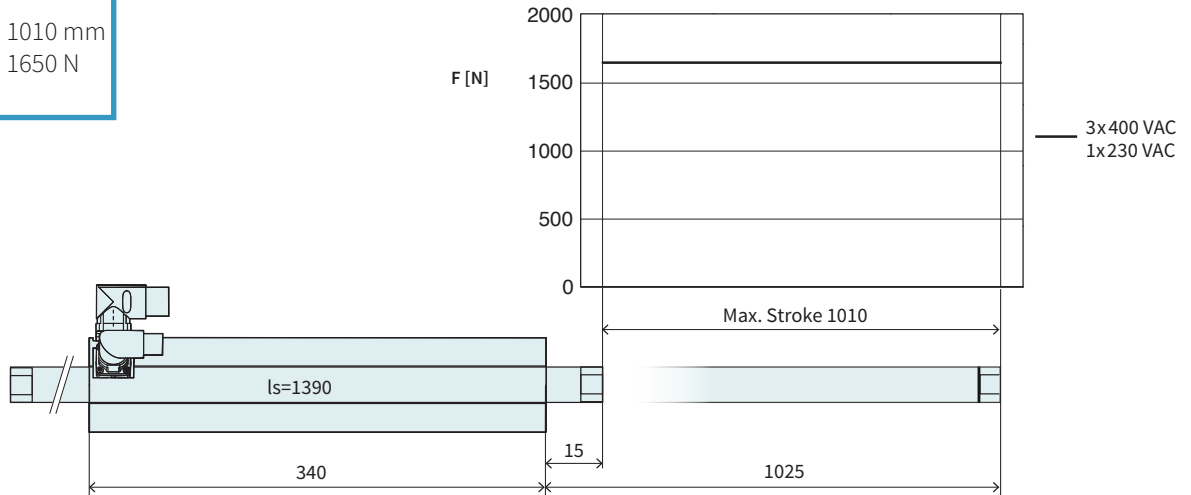

Dimensions in mm

Technical Data P10-70x240U/1010

Stroke			
Max. Stroke	mm	(in)	1010 (39.79)
Force			
Max. Force @ 1x230VAC	N	(lbf)	1650 (371)
Max. Force @ 3x400VAC	N	(lbf)	1650 (371)
Max. Cont. Force [Passive cooling / Fan / Fluid]	N	(lbf)	190 / 290 / 510 (43 / 66 / 120)
Max. Border Force relative	%		100
Force Constant 1	N/A _{pk}	(lbf/A _{pk})	59 (13.3)
Force Constant 2	N/A _{rms}	(lbf/A _{rms})	83.4 (18.8)
Velocity			
Max. Velocity @ 1x230VAC	m/s	(in/s)	3 (119.9)
Max. Velocity @ 3x400VAC	m/s	(in/s)	5.4 (5.4)
Position Detection			
Repeatability	mm	(in)	±0.05 (±0.002)
Linearity	%		± 0.15
Electrical Data			
Max. Current @ 1x230VAC	A _{pk} / A _{rms}		27.9 / 19.7
Max. Current @ 3x400VAC	A _{pk} / A _{rms}		27.9 / 19.7
Max. Cont. Current 1 [Passive cooling / Fan / Fluid]	A _{pk}		3.3 / 5 / 8.7
Max. Cont. Current 2 [Passive cooling / Fan / Fluid]	A _{rms}		2.3 / 3.5 / 6.1
Thermal Data			
Max. Winding Temperature (Sensor)	°C		90
Thermal Resistance [Passive cooling / Fan / Fluid]	*K/W		0.87 / 0.38 / 0.12
Thermal Time Constant [Passive cooling / Fan / Fluid]	s		2100 / 510 / 110
Mechanical Data			
Slider Length	mm	(in)	1390 (55)
Slider Mass	g	(lb)	6530 (14.37)



Item	Description	Item-No.
PS10-70x240U-BL-QJ	Stator 3x400VAC, LinMot Encoder	0150-1293
PS10-70x240U-BL-QJ-D01	Stator 3x400VAC, Sin/Cos Encoder 1Vpp, KTY	0150-2284
PS10-70x240U-BL-QJ-D02	Stator 3x400VAC, Sin/Cos Encoder 1Vpp, PTC	0150-2362
PS10-70x240U-BL-QJ-D03	Stator 3x400VAC, Sin/Cos 1Vpp, KTY on power connector	0150-2710
PL10-28x1390/1340	Slider for P10-70 'standard'	0150-2205

P10-70x240U/1210-BL-QJ

Max. Stroke: 1210 mm
Peak Force: 1650 N

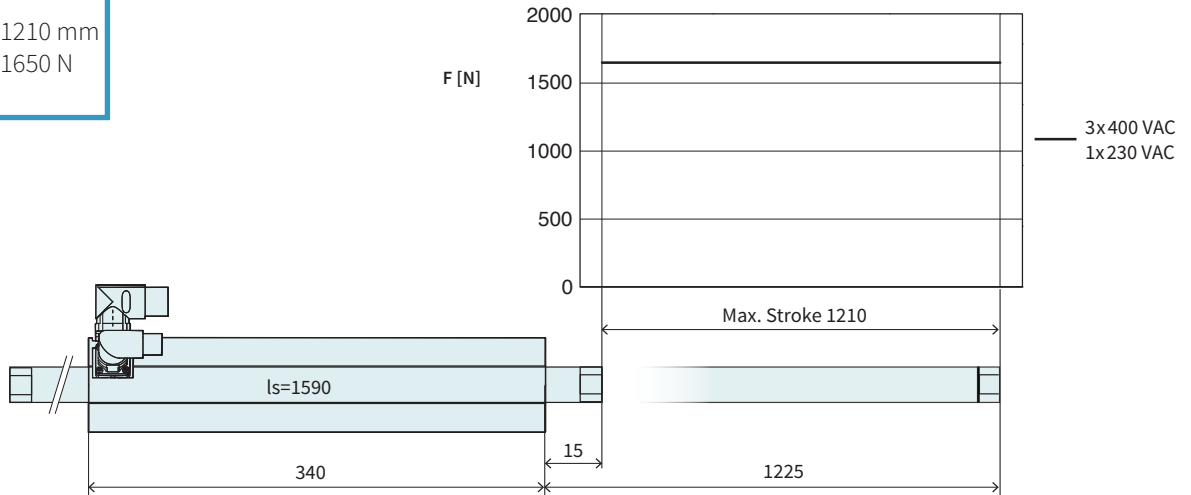

Dimensions in mm

Technical Data P10-70x240U/1210			
Stroke			
Max. Stroke	mm (in)	1210 (47.6)	
Force			
Max. Force @ 1x230VAC	N (lbf)	1650 (371)	
Max. Force @ 3x400VAC	N (lbf)	1650 (371)	
Max. Cont. Force [Passive cooling / Fan / Fluid]	N (lbf)	190 / 290 / 510 (43 / 66 / 120)	
Max. Border Force relative	%	100	
Force Constant 1	N/A _{pk} (lbf/A _{pk})	59 (13.3)	
Force Constant 2	N/A _{rms} (lbf/A _{rms})	83.4 (18.8)	
Velocity			
Max. Velocity @ 1x230VAC	m/s (in/s)	3 (119.9)	
Max. Velocity @ 3x400VAC	m/s (in/s)	5.4 (5.4)	
Position Detection			
Repeatability	mm (in)	±0.05 (±0.002)	
Linearity	%	± 0.15	
Electrical Data			
Max. Current @ 1x230VAC	A _{pk} / A _{rms}	27.9 / 19.7	
Max. Current @ 3x400VAC	A _{pk} / A _{rms}	27.9 / 19.7	
Max. Cont. Current 1 [Passive cooling / Fan / Fluid]	A _{pk}	3.3 / 5 / 8.7	
Max. Cont. Current 2 [Passive cooling / Fan / Fluid]	A _{rms}	2.3 / 3.5 / 6.1	
Thermal Data			
Max. Winding Temperature (Sensor)	°C	90	
Thermal Resistance [Passive cooling / Fan / Fluid]	°K/W	0.87 / 0.38 / 0.12	
Thermal Time Constant [Passive cooling / Fan / Fluid]	s	2100 / 510 / 110	
Mechanical Data			
Slider Length	mm (in)	1590 (63)	
Slider Mass	g (lb)	7470 (16.43)	

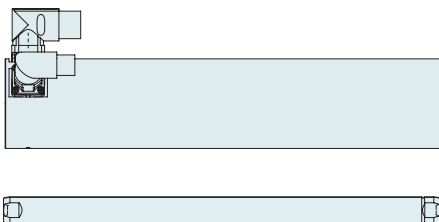

Item	Description	Item-No.
PS10-70x240U-BL-QJ	Stator 3x400VAC, LinMot Encoder	0150-1293
PS10-70x240U-BL-QJ-D01	Stator 3x400VAC, Sin/Cos Encoder 1Vpp, KTY	0150-2284
PS10-70x240U-BL-QJ-D02	Stator 3x400VAC, Sin/Cos Encoder 1Vpp, PTC	0150-2362
PS10-70x240U-BL-QJ-D03	Stator 3x400VAC, Sin/Cos 1Vpp, KTY on power connector	0150-2710
PL10-28x1590/1540	Slider for P10-70 'standard'	0150-2206

P10-70x240U/1410-BL-QJ

Max. Stroke: 1410 mm
Peak Force: 1650 N

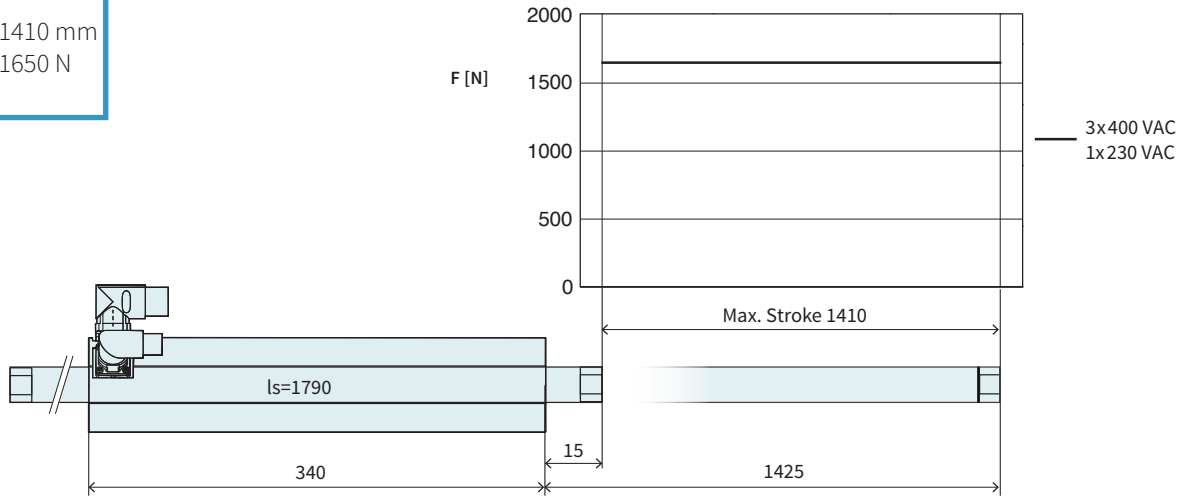

Dimensions in mm

Technical Data P10-70x240U/1410

Technical Data P10-70x240U/1410			
Stroke			
Max. Stroke	mm (in)		1410 (55.49)
Force			
Max. Force @ 1x230VAC	N (lbf)		1650 (371)
Max. Force @ 3x400VAC	N (lbf)		1650 (371)
Max. Cont. Force [Passive cooling / Fan / Fluid]	N (lbf)		190 / 290 / 510 (43 / 66 / 120)
Max. Border Force relative	%		100
Force Constant 1	N/A _{pk} (lbf/A _{pk})		59 (13.3)
Force Constant 2	N/A _{rms} (lbf/A _{rms})		83.4 (18.8)
Velocity			
Max. Velocity @ 1x230VAC	m/s (in/s)		3 (119.9)
Max. Velocity @ 3x400VAC	m/s (in/s)		5.4 (5.4)
Position Detection			
Repeatability	mm (in)		±0.05 (±0.002)
Linearity	%		± 0.15
Electrical Data			
Max. Current @ 1x230VAC	A _{pk} / A _{rms}		27.9 / 19.7
Max. Current @ 3x400VAC	A _{pk} / A _{rms}		27.9 / 19.7
Max. Cont. Current 1 [Passive cooling / Fan / Fluid]	A _{pk}		3.3 / 5 / 8.7
Max. Cont. Current 2 [Passive cooling / Fan / Fluid]	A _{rms}		2.3 / 3.5 / 6.1
Thermal Data			
Max. Winding Temperature (Sensor)	°C		90
Thermal Resistance [Passive cooling / Fan / Fluid]	*K/W		0.87 / 0.38 / 0.12
Thermal Time Constant [Passive cooling / Fan / Fluid]	s		2100 / 510 / 110
Mechanical Data			
Slider Length	mm (in)		1790 (70)
Slider Mass	g (lb)		8413 (18.51)



Item	Description	Item-No.
PS10-70x240U-BL-QJ	Stator 3x400VAC, LinMot Encoder	0150-1293
PS10-70x240U-BL-QJ-D01	Stator 3x400VAC, Sin/Cos Encoder 1Vpp, KTY	0150-2284
PS10-70x240U-BL-QJ-D02	Stator 3x400VAC, Sin/Cos Encoder 1Vpp, PTC	0150-2362
PS10-70x240U-BL-QJ-D03	Stator 3x400VAC, Sin/Cos 1Vpp, KTY on power connector	0150-2710
PL10-28x1790/1740	Slider for P10-70 'standard'	0150-2207

P10-70x240U/1610-BL-QJ

Max. Stroke: 1610 mm
Peak Force: 1650 N

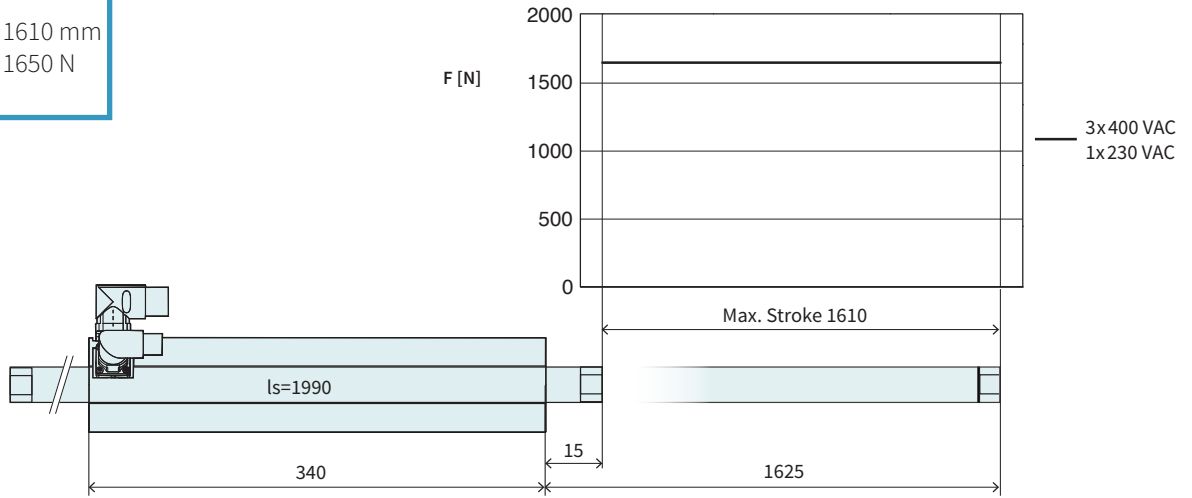

Dimensions in mm

Technical Data P10-70x240U/1610			
Stroke			
Max. Stroke	mm (in)	1610	(63.39)
Force			
Max. Force @ 1x230VAC	N (lbf)	1650	(371)
Max. Force @ 3x400VAC	N (lbf)	1650	(371)
Max. Cont. Force [Passive cooling / Fan / Fluid]	N (lbf)	190 / 290 / 510	(43 / 66 / 120)
Max. Border Force relative	%	100	
Force Constant 1	N/A _{pk} (lbf/A _{pk})	59	(13.3)
Force Constant 2	N/A _{rms} (lbf/A _{rms})	83.4	(18.8)
Velocity			
Max. Velocity @ 1x230VAC	m/s (in/s)	3	(119.9)
Max. Velocity @ 3x400VAC	m/s (in/s)	5.4	(5.4)
Position Detection			
Repeatability	mm (in)	±0.05	(±0.002)
Linearity	%	± 0.15	
Electrical Data			
Max. Current @ 1x230VAC	A _{pk} / A _{rms}	27.9 / 19.7	
Max. Current @ 3x400VAC	A _{pk} / A _{rms}	27.9 / 19.7	
Max. Cont. Current 1 [Passive cooling / Fan / Fluid]	A _{pk}	3.3 / 5 / 8.7	
Max. Cont. Current 2 [Passive cooling / Fan / Fluid]	A _{rms}	2.3 / 3.5 / 6.1	
Thermal Data			
Max. Winding Temperature (Sensor)	°C	90	
Thermal Resistance [Passive cooling / Fan / Fluid]	°K/W	0.87 / 0.38 / 0.12	
Thermal Time Constant [Passive cooling / Fan / Fluid]	s	2100 / 510 / 110	
Mechanical Data			
Slider Length	mm (in)	1990	(78)
Slider Mass	g (lb)	9350	(20.57)



Item	Description	Item-No.
PS10-70x240U-BL-QJ	Stator 3x400VAC, LinMot Encoder	0150-1293
PS10-70x240U-BL-QJ-D01	Stator 3x400VAC, Sin/Cos Encoder 1Vpp, KTY	0150-2284
PS10-70x240U-BL-QJ-D02	Stator 3x400VAC, Sin/Cos Encoder 1Vpp, PTC	0150-2362
PS10-70x240U-BL-QJ-D03	Stator 3x400VAC, Sin/Cos 1Vpp, KTY on power connector	0150-2710
PL10-28x1990/1940	Slider for P10-70 'standard'	0150-2208

Linear Guides H10



HM10-70x240/110 | Linear Module 70x240 with 110 mm Stroke

→	H-Guide	H10-70x240/110	H-Guide for P10-70x240, Stroke max. 110 mm	0150-5185	
	→	Stator	PS10-70x240U-BL-QJ	Stator 3x400VAC, LinMot Encoder	0150-1293
			PS10-70x240U-BL-QJ-D01	Stator 3x400VAC, Sin/Cos Encoder 1Vpp, KTY	0150-2284
			PS10-70x240U-BL-QJ-D02	Stator 3x400VAC, Sin/Cos Encoder 1Vpp, PTC	0150-2362
			PS10-70x240U-BL-QJ-D03	Stator 3x400VAC, Sin/Cos 1Vpp, KTY on power connector	0150-2710
→	Slider	PL10-28x490/440	Slider for P10-70 'standard'	0150-2195	

HM10-70x240/210 | Linear Module 70x240 with 210 mm Stroke

→	H-Guide	H10-70x240/210	H-Guide for P10-70x240, Stroke max. 210 mm	0150-5400	
	→	Stator	PS10-70x240U-BL-QJ	Stator 3x400VAC, LinMot Encoder	0150-1293
			PS10-70x240U-BL-QJ-D01	Stator 3x400VAC, Sin/Cos Encoder 1Vpp, KTY	0150-2284
			PS10-70x240U-BL-QJ-D02	Stator 3x400VAC, Sin/Cos Encoder 1Vpp, PTC	0150-2362
			PS10-70x240U-BL-QJ-D03	Stator 3x400VAC, Sin/Cos 1Vpp, KTY on power connector	0150-2710
→	Slider	PL10-28x590/540	Slider for P10-70 'standard'	0150-2196	

HM10-70x240/310 | Linear Module 70x240 with 310 mm Stroke

→	H-Guide	H10-70x240/310	H-Guide for P10-70x240, Stroke max. 310 mm	0150-5401	
	→	Stator	PS10-70x240U-BL-QJ	Stator 3x400VAC, LinMot Encoder	0150-1293
			PS10-70x240U-BL-QJ-D01	Stator 3x400VAC, Sin/Cos Encoder 1Vpp, KTY	0150-2284
			PS10-70x240U-BL-QJ-D02	Stator 3x400VAC, Sin/Cos Encoder 1Vpp, PTC	0150-2362
			PS10-70x240U-BL-QJ-D03	Stator 3x400VAC, Sin/Cos 1Vpp, KTY on power connector	0150-2710
→	Slider	PL10-28x690/640	Slider for P10-70 'standard'	0150-2197	

FIND MORE PRODUCT DETAILS IN THE CHAPTER "LINEAR GUIDES".

HM10-70x240/410		Linear Module 70x240 with 410 mm Stroke		
→	H-Guide	H10-70x240/410	H-Guide for P10-70x240, Stroke max. 410 mm	0150-5402
	Stator	PS10-70x240U-BL-QJ	Stator 3x400VAC, LinMot Encoder	0150-1293
		PS10-70x240U-BL-QJ-D01	Stator 3x400VAC, Sin/Cos Encoder 1Vpp, KTY	0150-2284
		PS10-70x240U-BL-QJ-D02	Stator 3x400VAC, Sin/Cos Encoder 1Vpp, PTC	0150-2362
		PS10-70x240U-BL-QJ-D03	Stator 3x400VAC, Sin/Cos 1Vpp, KTY on power connector	0150-2710
Slider	PL10-28x790/740	Slider for P10-70 'standard'	0150-2198	
HM10-70x240/510		Linear Module 70x240 with 510 mm Stroke		
→	H-Guide	H10-70x240/510	H-Guide for P10-70x240, Stroke max. 510 mm	0150-5403
	Stator	PS10-70x240U-BL-QJ	Stator 3x400VAC, LinMot Encoder	0150-1293
		PS10-70x240U-BL-QJ-D01	Stator 3x400VAC, Sin/Cos Encoder 1Vpp, KTY	0150-2284
		PS10-70x240U-BL-QJ-D02	Stator 3x400VAC, Sin/Cos Encoder 1Vpp, PTC	0150-2362
		PS10-70x240U-BL-QJ-D03	Stator 3x400VAC, Sin/Cos 1Vpp, KTY on power connector	0150-2710
Slider	PL10-28x890/840	Slider for P10-70 'standard'	0150-2199	
Accessories				
→	Fan	HV01-37/48	Fan cooling for H01-37/48 & PF02-37/48	0150-5051

4

Motor Cable

4

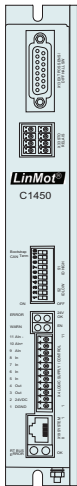

C1400

B Connector MC10-B/m

Q Connector MC10-Q/f

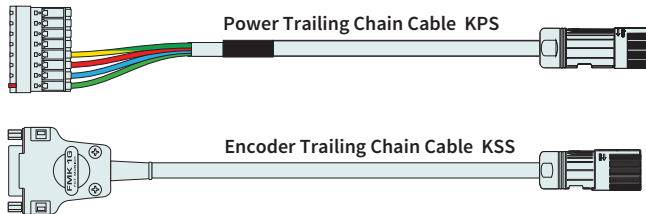

P10-70x240U

D15 Connector MC01-D15/f

J Connector MC10-J/f



E1400

L Connector MC10-L/m

Q Connector MC10-Q/f

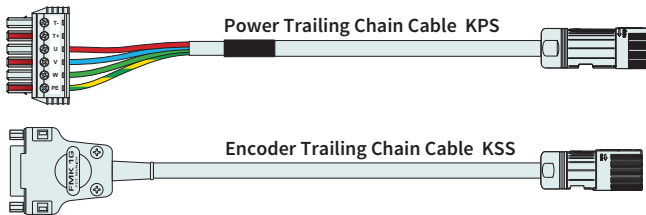

P10-70x240U

D15 Connector MC01-D15/f

J Connector MC10-J/f

ORDERING INFORMATION

TRAILING CHAIN CABLE FOR LINMOT DRIVES

Item	Description	Item-No.
KPS15-04-L/Q-3	Power Trailing Chain Cable E1400/P10-70, 3 m	0150-2266
KPS15-04-L/Q-5	Power Trailing Chain Cable E1400/P10-70, 5 m	0150-2261
KPS15-04-L/Q-8	Power Trailing Chain Cable E1400/P10-70, 8 m	0150-2267
KPS15-04-L/Q-12	Power Trailing Chain Cable E1400/P10-70, 12 m	0150-2268
KPS15-04-L/Q-	Power Trailing Chain Cable L/Q-, Custom length	0150-3388
KPS15-04-B/Q-3	Power Trailing Chain Cable C1400/P10-70, 3 m	0150-3660
KPS15-04-B/Q-5	Power Trailing Chain Cable C1400/P10-70, 5 m	0150-3661
KPS15-04-B/Q-8	Power Trailing Chain Cable C1400/P10-70, 8 m	0150-3662
KPS15-04-B/Q-12	Power Trailing Chain Cable C1400/P10-70, 12 m	0150-3663
KPS15-04-B/Q-	Power Trailing Chain Cable B/Q-, Custom length	0150-3608

TRAILING CHAIN CABLE FOR LINMOT DRIVES

Item	Description	Item-No.
KSS 05-02/08-D15/J-3	Encoder Trailing Chain Cable D15/J, 3 m	0150-2263
KSS 05-02/08-D15/J-5	Encoder Trailing Chain Cable D15/J, 5 m	0150-2262
KSS 05-02/08-D15/J-8	Encoder Trailing Chain Cable D15/J, 8 m	0150-2264
KSS 05-02/08-D15/J-12	Encoder Trailing Chain Cable D15/J, 12 m	0150-2265
KSS 05-02/08-D15(f)-45°/J-	Encoder Trailing Chain Cable D15/J-, Custom length	0150-3389

TRAILING CHAIN CABLE FOR STATOR SERIES D01 / D02

Item	Description	Item-No.
KPS15-04-.../Q-10	Power Trailing Chain Cable .../Q, 10 m for D0x	0150-2376
KPS15-04-./Q-	Power Trailing Chain Cable .../Q, for D0x, Custom length	0150-3491
KSS05-02/13-./J-10	Encoder Trailing Chain Cable ./J, 10 m for D0x	0150-2377
KSS05-02/13-./J-	Encoder Trailing Chain Cable ./J, for D0x, Custom length	0150-3492
KPS15-04	Power Trailing Chain Cable P10-70 (per m)	0150-2257
KSS05-02/13	Trailing Chain Cable Encoder P10-...-Dxx (per m)	0150-2259

TRAILING CHAIN CABLE FOR STATOR SERIES D03

Item	Description	Item-No.
KPS15-04/04.../Q-10	Power Trailing Chain Cable .../Q, 10 m for D03	0150-3654
KPS15-04/04-./Q-	Power Trailing Chain Cable .../Q, for D03, Custom length	0150-3579
KSS05-02/06-./J-10	Encoder Trailing Chain Cable ./J, 10 m for D03	0150-3655
KSS05-02/06-./J-	Encoder Trailing Chain Cable ./J, for D03, Custom length	0150-3611
KPS15-04/04	Power Trailing Chain Cable P10-...-Dx3 (per m)	0150-2269
KSS05-02/06	Trailing Chain Cable Encoder P10-...-Dx3 (per m)	0150-2490

CONNECTOR

Item	Description	Item-No.
MC10-L/m	Connector Power E1400/X2	0150-3382
MC01-D15/f	Motor Connector D15 (f)	0150-3136
MC10-Q/f	Connector Power PS10-70	0150-2268
MC10-J/f	Connector Encoder PS10-70	0150-2269

MOTOR FLANGES

4



Item	Description	Item-No.
PF10-70x270	Flange for PS10-70x240	0150-2274



Item	Description	Item-No.
PF10-70x270-FC	Flange for PS10-70x240 fluid cooling	0150-2293

FIND MORE PRODUCT DETAILS IN THE CHAPTER "ACCESSORIES".

FANS



Item	Description	Item-No.
HV01-37/48	Fan cooling for H01-37/48 & PF02-37/48	0150-5051

FIND MORE PRODUCT DETAILS IN THE CHAPTER "ACCESSORIES".

SLIDER MOUNTING



Item	Description	Item-No.
PLF01-28	Fixed Bearing Set for 27/28 mm sliders	0150-3087
PLF01-28-SS	Fixed Bearing Set for 27/28 mm sliders, stainless steel	0150-3297
PLL01-28	Floating Bearing for 28 mm sliders	0150-3094
PLM01-28-MK	Mounting Kit for 28 mm sliders	0150-3095

FIND MORE PRODUCT DETAILS IN THE CHAPTER "ACCESSORIES".

BEARING KIT



Item	Description	Item-No.
PB10-70x240-L	Bearing Kit for PS10-70x240	0150-3433

FIND MORE PRODUCT DETAILS IN THE CHAPTER "ACCESSORIES".

LUBRICANT RESERVOIR



Item	Description	Item-No.
PA10-70/28	Lubricant reservoir for PS10-70 with lubricating nipple	0150-3543

EXTERNAL POSITION SENSORS

4

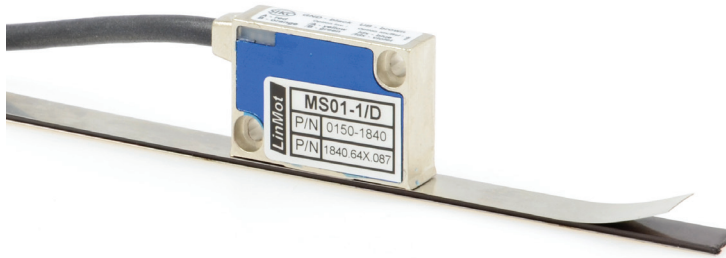

Item	Description	Item-No.
MS01-1/D	Linear Encoder 1µm, A/B (for incremental strip)	0150-1840
MB01-1000	Magnetic incremental strip for MS01-1/D, per cm	0150-1963
KS025-D15/D-Encoder	Encoder Cable (Length in m)	0150-3168

FIND MORE PRODUCT DETAILS IN THE CHAPTER "ACCESSORIES".



Item	Description	Item-No.
MS01-1/D-SSI	Linear Encoder 1µm, A/B (for absolute strip)	0150-2095
MB01-1000-ABS	Magnetic absolute strip for MS01-1/D-SSI (per cm)	0150-2096
EC01-ABS/ENC-12-S	MS01-1/D-SSI Encoder connector straight	0150-3616
KSS01-12-D15/ABS-ENC	Special cable for MS01-1/D-SSI on C1100/C1200/C1400/E1200/E1400 Drives	0150-3652

FIND MORE PRODUCT DETAILS IN THE CHAPTER "ACCESSORIES".