

**Save
Engineering
Time!**

new
MiniSlide™
motorized with
Hybrid Stepper Actuator

small size, big power

Exceedingly configurable, simple to integrate MiniSlide™ assembly is ideally suited for small lab and automation equipment.

Compact, low profile

Super efficient motor

Small step resolution with 1.8° step angle

High power density and force

Encoder or encoder-ready options

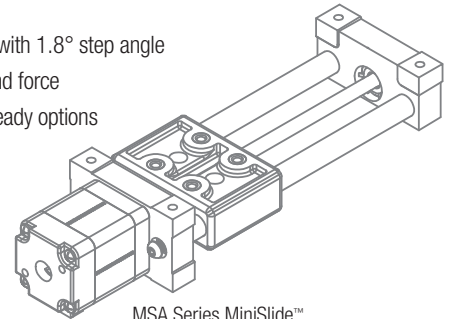

Size 8 Hybrid Stepper Linear Actuator: 21 mm (0.8-in) (1.8° Step Angle)			
Wiring	Bipolar		
Winding Voltage	2.5 VDC	5 VDC	7.5 VDC
Current (RMS)/phase	.49 A	.24 A	.16 A
Resistance/phase	5.1 Ω	20.4 Ω	45.9 Ω
Inductance/phase	1.5 mH	5.0 mH	11.7 mH
Power Consumption	2.45 W		
Rotor Inertia	1.4 gcm ²		
Insulation Class	Class B (Class F available)		
Weight	1.5 oz (43 g)		
Insulation Resistance	20 MΩ		

MiniSlide is also available with 20mm Can-Stack Motor.

Performance Curves

Force vs. Pulse Rate

– Chopper – 100% Duty Cycle – Bipolar – 0.14 (3.56) Lead Screw

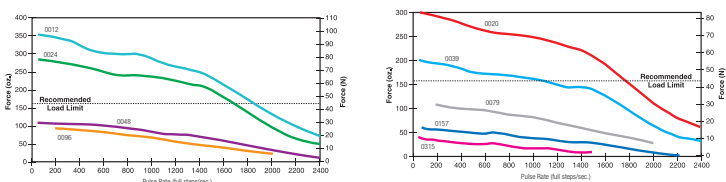

Force vs. Linear Velocity

– Chopper – 100% Duty Cycle – Bipolar – 0.14 (3.56) Lead Screw

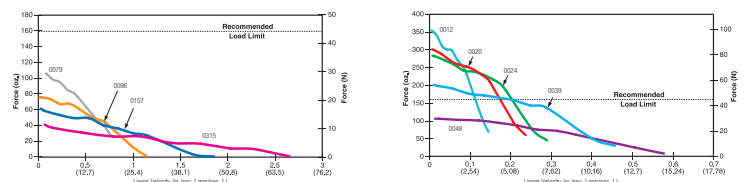

NOTE: All chopper drive curves were created with a 5 volt motor and a 40 watt power supply. Ramping can increase the performance of a motor either by increasing the top speed or getting a heavier load accelerated up to speed faster. Also, deceleration can be used to stop the motor without overshoot. With L/R drives peak force and speeds are reduced, using a unipolar drive will yield a further 30% force reduction.



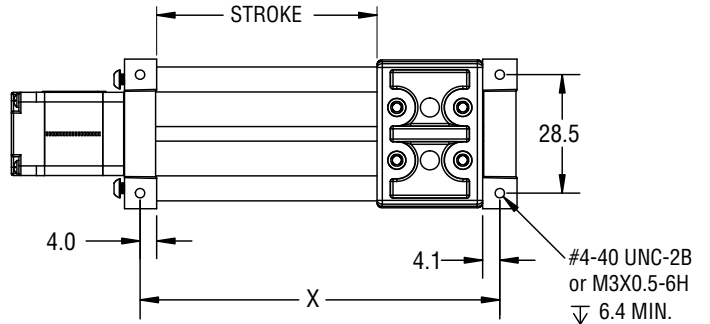
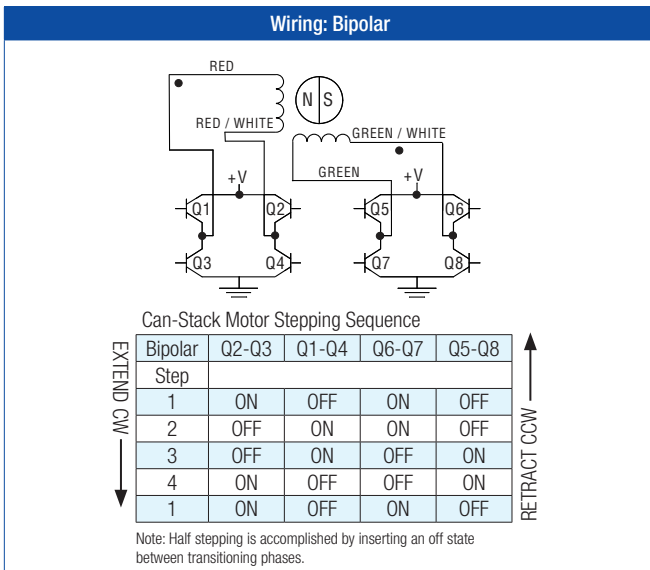
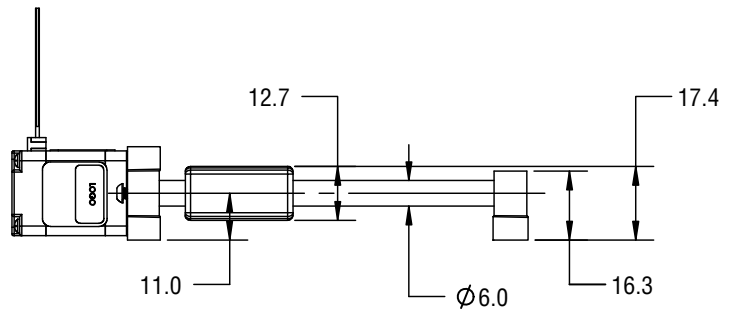
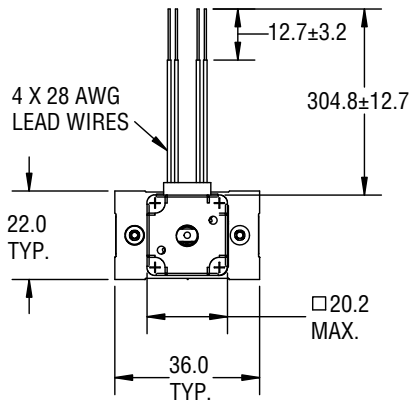
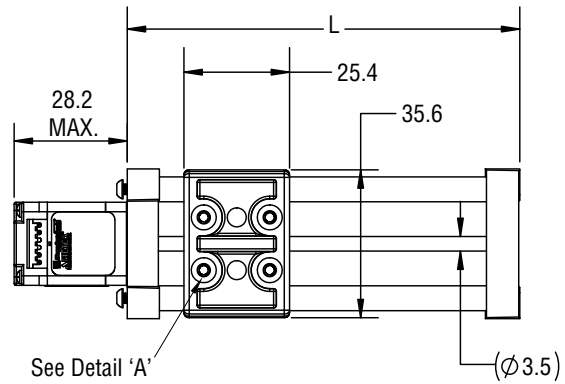
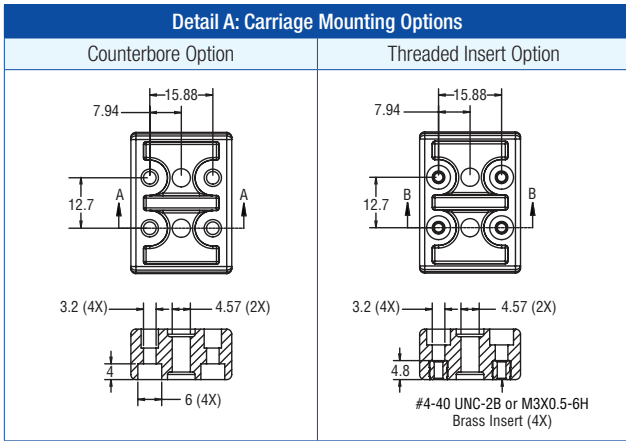

Dimensions		
Stroke	Rail Length "L"	Mounting Holes "X"
25 mm	69.4 mm	61.5 mm
50 mm	94.4 mm	86.5 mm
75 mm	119.4 mm	111.5 mm
100 mm	144.4 mm	136.5 mm

Ordering Part Numbers for MiniSlide™ motorized with Size 8 Hybrid Stepper Actuator

MSA	02	K	H	0020	XXX
Prefix	Frame Size	Coating	Motor	Nominal Thread Lead Code	Unique Identifier
MSA = Mini Slide Actuator	02 = 1/8" Screws	K = TFE Kerkote B = TFE Black Ice G = Grease S = No Lubricant	H = Size 8 Hybrid Stepper Linear Actuator	0020 = 1/2mm lead 0039 = 1mm lead 0079 = 2mm lead 0157 = 4mm lead 0315 = 8mm lead 0012 = 0.012" lead 0024 = 0.024" lead 0048 = 0.048" lead 0096 = 0.096" lead	805 = 50mm stroke M3 mounting 810 = 100mm stroke M3 mounting 905 = 50mm stroke #4-40 mounting 910 = 100mm stroke #4-40 mounting

NOTE: Dashes must be included in the Part Number (-) as shown above. For assistance call our Engineering Team at 203 756 7441.