

Installation Guide Linear Motors

ENG

P10-54 / P10-54-Dxx



Content

1	General information	4
1.1	Introduction	4
1.2	Explanation of symbols	4
1.3	Qualified personnel	4
1.4	Liability	4
1.5	Copyright	4
2	Safety instructions	5
3	Installation instructions	7
3.1	Operating conditions	7
3.2	Instructions for installing the linear motor	7
3.3	Mounting the stator	8
3.4	Mounting the payload to the slider	8
3.5	"Moving slider" installation	10
3.6	"Moving stator" installation	10
3.6.1	Assembling instruction	11
3.7	Minimum distance from slider	13
3.7.1	Minimum distance from slider to slider	13
3.7.2	Minimum distance from slider to metallic parts	13
4	Stroke Range	14
5	Electrical Connection	14
5.1	Technical Data of Motor Cables	14
5.2	Stator connector assignment	15
5.2.1	Power Connector	15
5.2.2	Encoder Connector	16
5.3	Attaching the cable shielding	18
5.4	Rotatability of motor connectors	18
6	Accessories	19
6.1	Motor Cables for use with LinMot Drives	19
6.2	Motor Cables for use with third-party Drives	20
6.3	Bearing kit	21
6.3.1	Overview	21
6.3.2	Mounting	22
6.4	Mounting flanges	23
6.5	Fan kits for flanges	25
6.6	Slider mounting kits	25
6.6.1	Fixed bearing	25
6.6.2	Floating bearing	26
6.6.3	Complete mounting kit	26
7	Maintenance and test instructions	27
7.1	Stator checking	27
7.2	Maintenance of linear motors	28
7.2.1	Mounting	28

7.2.2	Inspection.....	28
7.2.3	Cleaning.....	28
7.2.4	Cleaning agent / Lubricant	28
8	Storage, transport, installation altitude	29
9	Dimensions	29
9.1	Stator	29
9.1.1	PS10-54x120	29
9.1.2	PS10-54x180	29
9.1.3	PS10-54x240	30
9.1.4	PS10-54x300	30
9.2	Slider	30
10	International Certificates.....	31
11	EU Declaration of Conformity CE-Marking	35
12	UK Declaration of Conformity UKCA-Marking.....	36

1 General information

1.1 Introduction

This manual includes instructions for the assembly, installation, maintenance, transport, and storage of linear motors. The document is intended for electricians, mechanics, service technicians, and warehouse staff. Be sure to observe the general safety instructions as well as those in each chapter at all times. Keep this manual accessible to the assigned staff.

1.2 Explanation of symbols



Triangular warning symbols warn against a danger.



Round command symbols tell what to do.

1.3 Qualified personnel

All work such as transport, installation, commissioning and service is only allowed to be carried out by qualified personnel. Qualified personnel in the sense of the safety instructions in this documentation are persons who are familiar with the transport, installation, assembly, commissioning and operation of the product and who have the appropriate qualifications.

This manual must be read carefully before transport, installation, commissioning, service and all safety-related information must be adhered to.

1.4 Liability

NTI AG (as manufacturer of LinMot linear motors and MagSpring products) excludes all liability for damages and expenses caused by incorrect use of the products. This also applies to false applications, which are caused by NTI AG's own data and notes, for example in the course of sales, support or application activities. It is the sole responsibility of the user to check the information and information provided by NTI AG regarding their safety-relevant correctness. In addition, the entire responsibility for safety-related product functionality lies exclusively with the user. Product warranties are void if products are used with stators, sliders, servo drives or cables not manufactured by NTI AG unless such use was specifically approved by NTI AG. NTI AG's warranty is limited to repair or replacement as stated in our standard warranty policy as described in our "terms and conditions" previously supplied to the purchaser of our equipment (please request copy of same if not otherwise available). Further reference is made to our general terms and conditions.

1.5 Copyright

This work is protected by copyright.

Under the copyright laws, this publication may not be reproduced or transmitted in any form, electronic or mechanical, including photocopying, recording, microfilm, storing in an information retrieval system, not even for training purposes, or translating, in whole or in part, without the prior written consent of NTI AG.

LinMot® is a registered trademark of NTI AG.

2 Safety instructions



Contusions

Sliders contain neodymium magnets and have a strong attractive force. Careless handling could cause fingers or skin to become pinched between two sliders. This may lead to contusions, bruises, and bone fractures.

When handling sliders, wear thick protective gloves and keep a minimum distance between sliders. Refer to the "Minimum distance from slider" section for minimum distance.

To reduce the risk of injury, never more than one slider should be held or transported by the same person without packaging.



Pacemaker / Implanted heart defibrillator

Sliders could affect the functioning of pacemakers and implanted heart defibrillators. For the duration of a strong approach to a magnetic field, these devices switch into test mode and will not function properly.

- If you wear one of those devices keep the following minimum distances between the pacemaker / defibrillator and slider:
 - Min. 250 mm (10") for slider Ø 27 mm and 28 mm (PL01-27 / 28 / PL10-28)
 - Min. 150 mm (6") for slider Ø 19 mm and 20 mm (PL01-19 / 20)
 - Min. 100 mm (4") for slider Ø 12 mm (PL01-12)
- Inform others who wear these devices to comply with these minimum distances!



Caution - Risk of Electric Shock !

Before working, make sure that there are no high voltages.



Fast-moving machine parts

The sliders of LinMot linear motors are fast-moving machine parts. All necessary precautions must be taken to prevent access during operation (provide covers, guards, etc.).



Automatic restart

The motors can start automatically under certain circumstances!

If necessary, a corresponding warning symbol must be provided and protection against entering the hazardous area or a suitable safe electronic disconnection must be provided!



Risk of injury due to a defect or fault

For areas where a defect or fault can result in substantial property damage or even serious personal injury, additional external precautions must be taken or devices must be installed to ensure safe operation even if a defect or fault occurs (eg. suitable safe electronic disconnection, mechanical interlocks, barriers, etc.).



Magnetic field

Magnets integrated in the sliders produce a strong magnetic field. They could damage TVs, laptops, computer hard drives, credit and ATM cards, data storage media, mechanical watches, hearing aids, and speakers.

- Keep magnets away from devices and objects that could be damaged by strong magnetic fields.
- For the above mentioned objects, keep a minimum distance as described in the "Pacemaker / implanted defibrillator" section.
- For non-anti-magnetic watches, keep the double minimum distance.

**Combustibility**

When machining magnets, the drilling dust could easily ignite. Machining the sliders and the magnets they contain is not permitted.

**Burn hazard**

The sliders of LinMot motors can reach temperatures of 80 °C, which may cause burns upon contact.

**Grounding**

All metal parts that are exposed to contact during any user operation or servicing and likely to become energized shall be reliably connected to the means for grounding.

**Mechanical handling**

Neodymium magnets are brittle and heat-sensitive. Machining the sliders and the magnets they contain is not permitted.

- Colliding magnets could crack. Sharp splinters could be catapulted for several meters and cause eye injury.
- By machining the sliders, heat would result which demagnetises the magnets.

**Slider**

Linear motor sliders consist of a high-precision, thin-walled stainless steel tube in which the neodymium magnets are housed. The LinMot sliders should be handled with care. Avoid contact with other sliders or iron parts as this can damage the magnets and the slider surface. Do not grip the sliders with pliers, as this can also damage the surface. Do not use sliders which are already damaged on the surface (scratches, deformation, etc.). This can cause further damage to the stator.

**Effects on people**

According to the current level of knowledge, magnetic fields of permanent magnets do not have a measurable positive or negative effect on people. It is unlikely that permanent magnets constitute a health risk, but it cannot be ruled out entirely.

- For your own safety, avoid constant contact with magnets.
- Store large magnets at least one meter away from your body.

**Temperature resistance**

Keep slider away from unshielded flame or heat. Temperature above 120°C will cause demagnetization.

3 Installation instructions

3.1 Operating conditions



Maximum ambient temperature limits:

- 10 °C...80 °C

Internal temperature sensor error occurs at:

- 90 °C

3.2 Instructions for installing the linear motor



Please attend to the safety instructions in chapter 2 during the assembling!



For maintenance purposes, please observe the installation instructions in chapter 6.

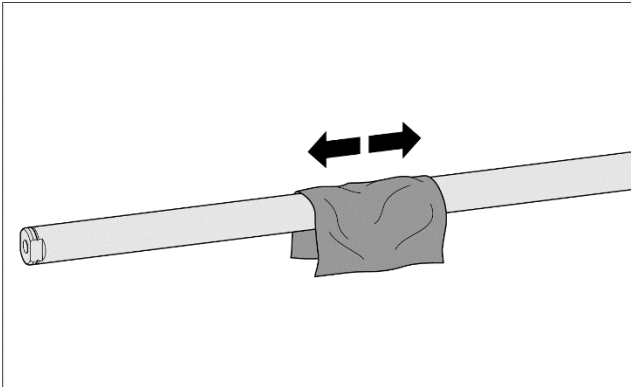

1. Clean the slider with a paper towel.

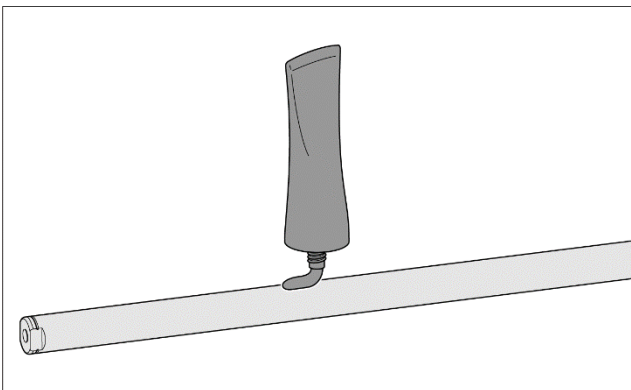

2. Lubrication of the slider

Sliders with a length ≤ 500 mm are inserted without lubrication.

Sliders with a length > 500 mm are lubricated with a grease amount of 4 g (0.14 oz) per meter, which is about $\frac{1}{2}$ of a hazel-nut.

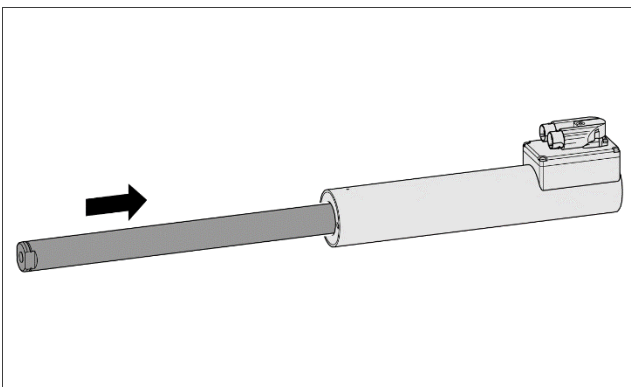

3. Insert the slider in the defined direction (see Assembly step 4.).

Attention! The slider is magnetically attracted.

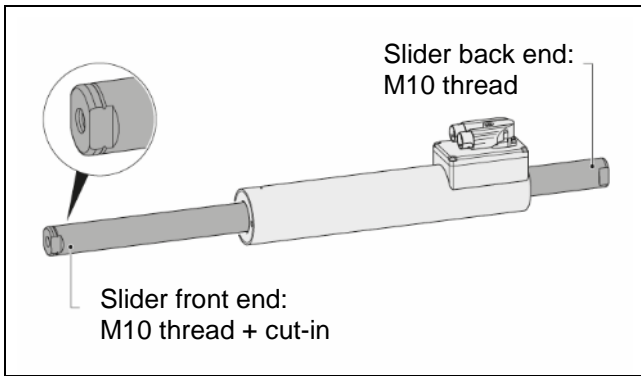

- 4. Checking the installed direction of slider**
After the installation, the front end of the slider with M 10 thread and cut-in is located at the opposite side of the stator from the cable exit.

3.3 Mounting the stator

The stator is mounted by clamping. The LinMot flange (see the section 5 « Accessories ») or a similar flange can be used for this purpose. Most important is a broad clamping surface in order to provide good heat dissipation. Additionally, the cooling can be increased by a fan or liquid (water cooling), so that the continuous power is significantly improved.



The flange clamp must not deform the stator.
Do not exceed max. torque of **12 Nm**.



Incorrect mounting
Small contact area prevents cooling of the linear motor.



Correct mounting
Better heat dissipation with the LinMot flange.



Correct mounting
Forced air cooling with LinMot fan to increase the continuous force.

3.4 Mounting the payload to the slider

The load is mounted as a fixed bearing using spherical washers and conical seats (see the section 5).



- To avoid shear force on slider and wear on stator, the payload has to be beared by a linear guide.
- Slider back end should not be used for load mounting.

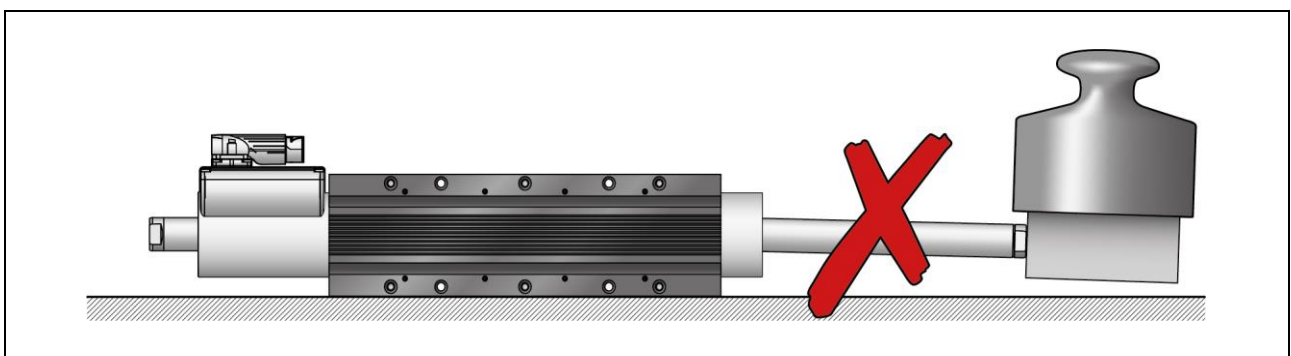

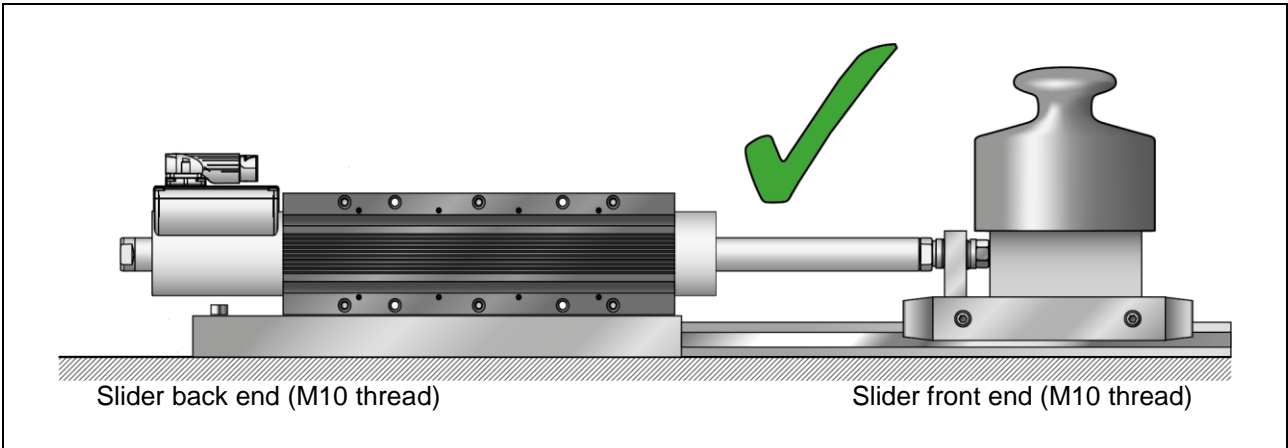

When attaching the load, the wrench for tightening the load must be used only on the load-facing side of the slider. Avoid torsional stress on slider (note the following figures).

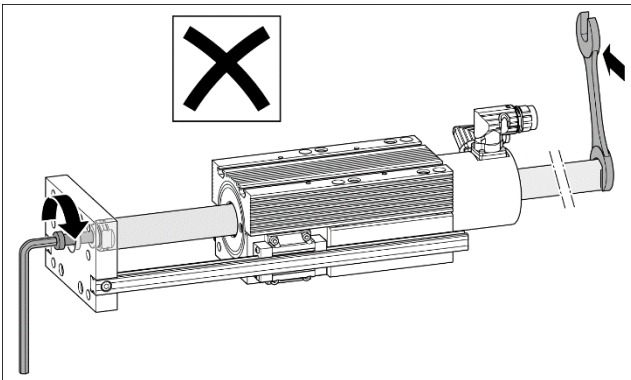

Incorrect mounting
Torsional stress on slider!

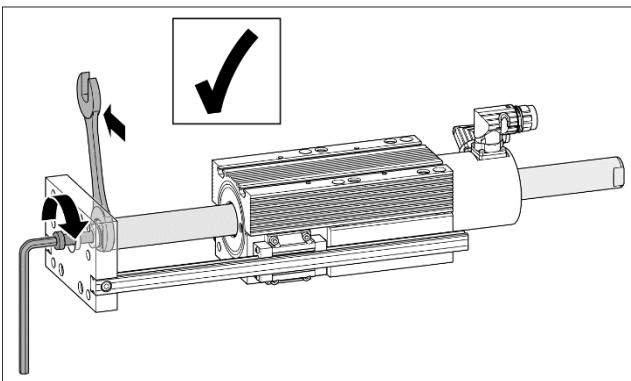

Correct mounting

Slider	Thread	Max. torque for screw (Dry)
28 mm	M 10	42 Nm

3.5 "Moving slider" installation

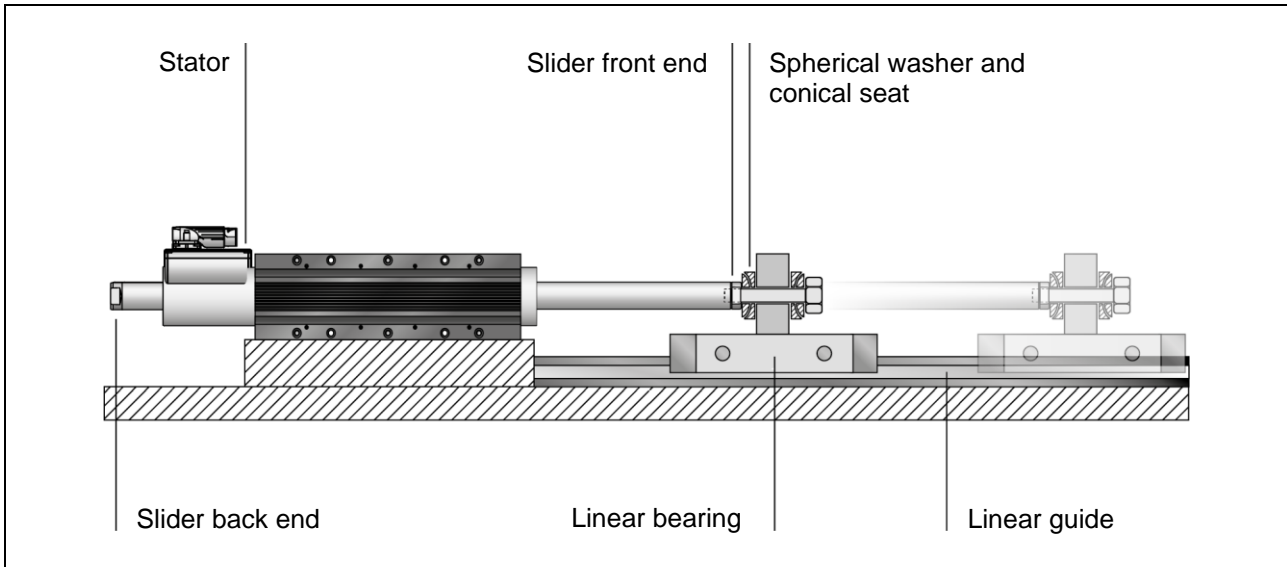

In a "moving slider" installation, the stator is fixed and the slider is the moving part. The load, borne by a linear guide, is attached directly to the end of the slider. In order to compensate for misalignment, spherical axial bearings consisting of spherical washers and conical seats (see the section Slider mounting kits) are used to connect to the load. The mounting kit of slider and an oversized hole for the screw make it possible to adjust a radial and angle offset.

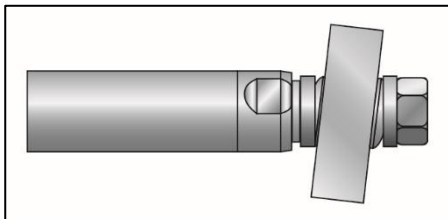

Mounted payload with radial and angle offset.

3.6 "Moving stator" installation

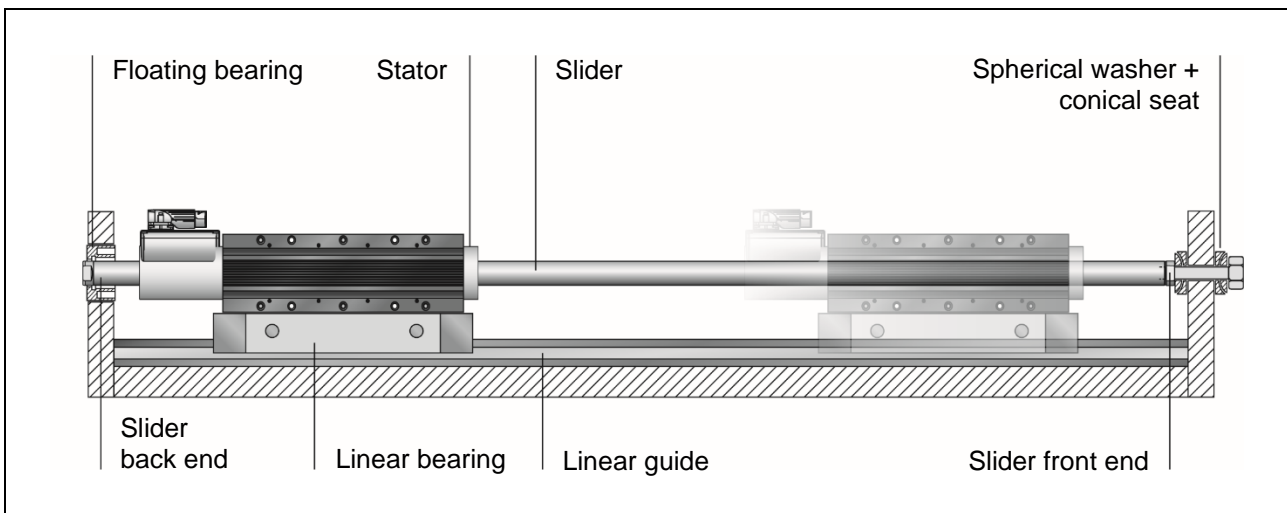

In "moving stator" applications, the slider is fixed and the stator is the moving part. The load is attached to the stator, which is mounted on a linear guide. In order to avoid an overconstrained bearing mount and compensate for alignment errors, the slider may be mounted on one end in a fixed bearing with a spherical axial bearing. On the opposite end, the slider is mounted in a floating bearing. Mounting kits are available for mounting the slider (see the section Slider mounting kits).

3.6.1 Assembling instruction



Please attend to the safety instructions in chapter 2 during the assembling!



If moving stator application is used, the minimum bending radius of the motor cable should be adhered to. See chapter Cable, section Technical Data.

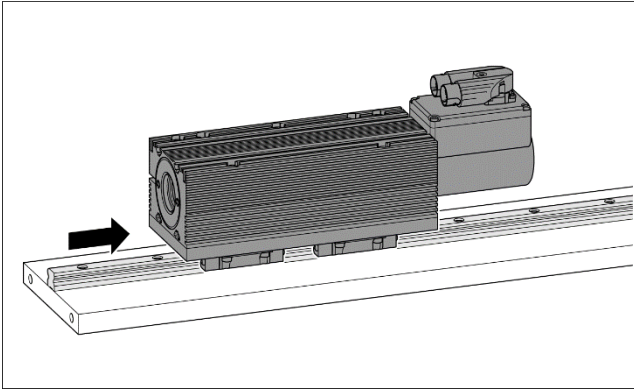

1. Mount stator to its support bearing.

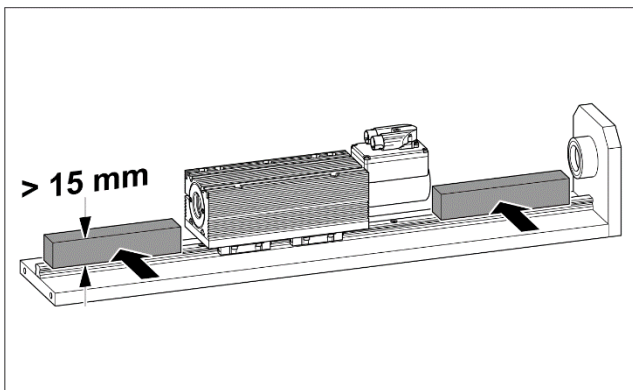

2. Placing a spacer

Put a spacer (wood, plastic, aluminium with thickness 15 mm) between slider and linear guide. The spacer prevents injuries to the hands and damage to the slider surface!

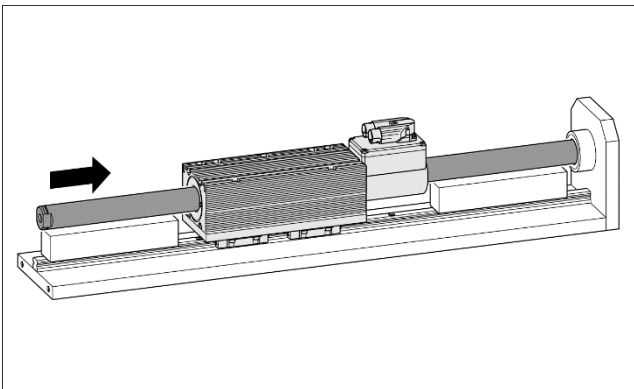

3. Insert slider into stator.

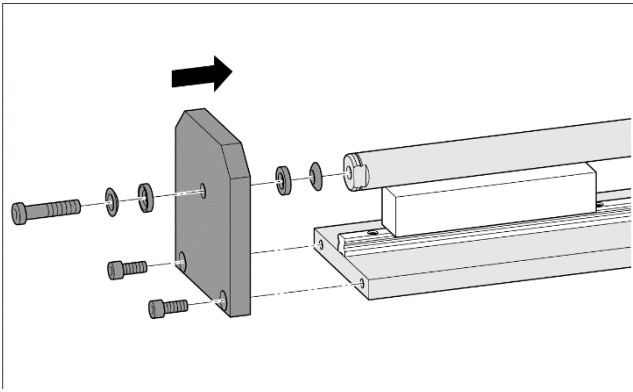

4. **Installing the slider using the fixed bearing**
 The fixed bearing is screwed to the front end of the slider.
Important! Do not tighten the screw yet!

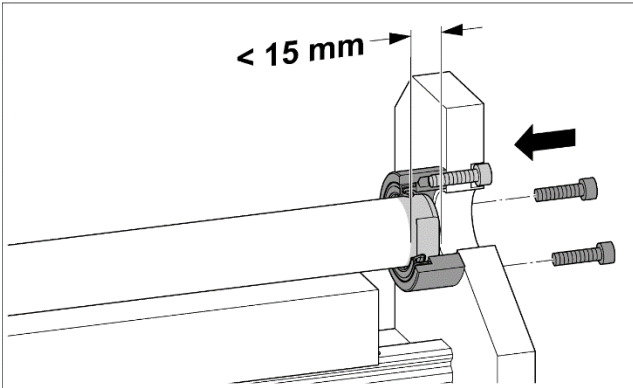

5. **Mount floating bearing**
Important!
 Do not tighten the screw!
 The slider is allowed to extend into the floating bearing no more than 15 mm!

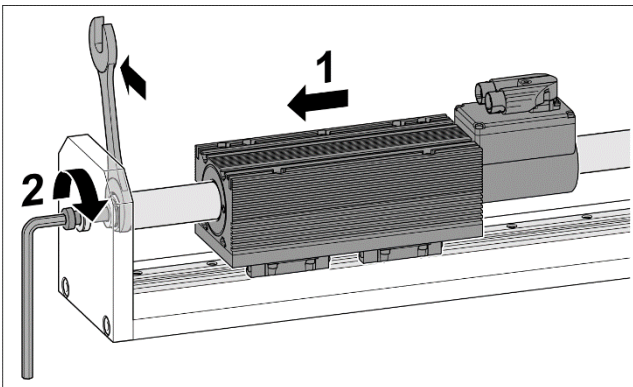

6. **Move stator (back end) to the fixed end of slider, center slider in stator and tighten the screw.**

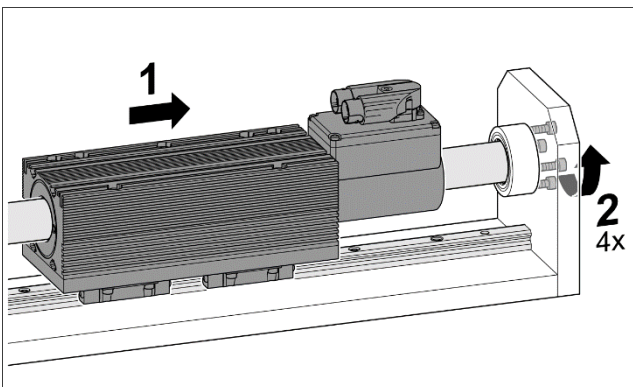

7. **Move stator (front side) to the floating bearing and tighten screws.**



After the installation of the slider a safety label must be placed close to the slider.

3.7 Minimum distance from slider

3.7.1 Minimum distance from slider to slider

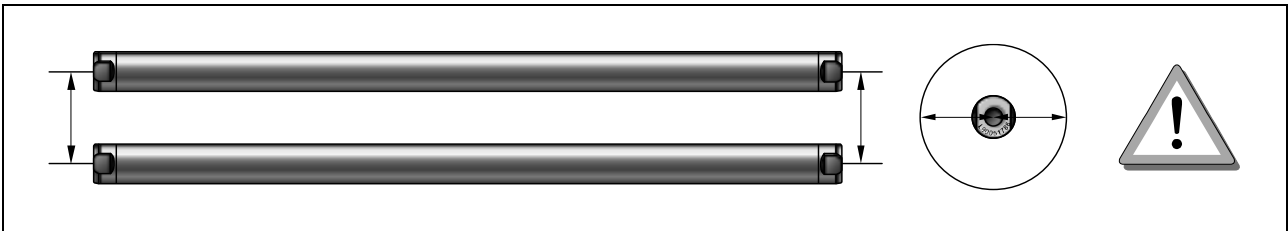

The sliders are made of neodymium magnets and have a strong magnetic attraction. It must be kept a minimum distance between the sliders. This minimized the risk of bruising and secondly, the sliders do not influence each other through their magnetic fields.

Type of slider	PL01	PL01-20 / PL01-19	PL01-28 / PL01-27	PL10-28
PL01-12	30 mm (1.18 in)			
PL01-20 / PL01-19		50 mm (1.97 in)		
PL01-28 / PL01-27			80 mm (3.15 in)	
PL10-28				70 mm (2.76 in)

The data are measured from slider center to slider center.

3.7.2 Minimum distance from slider to metallic parts

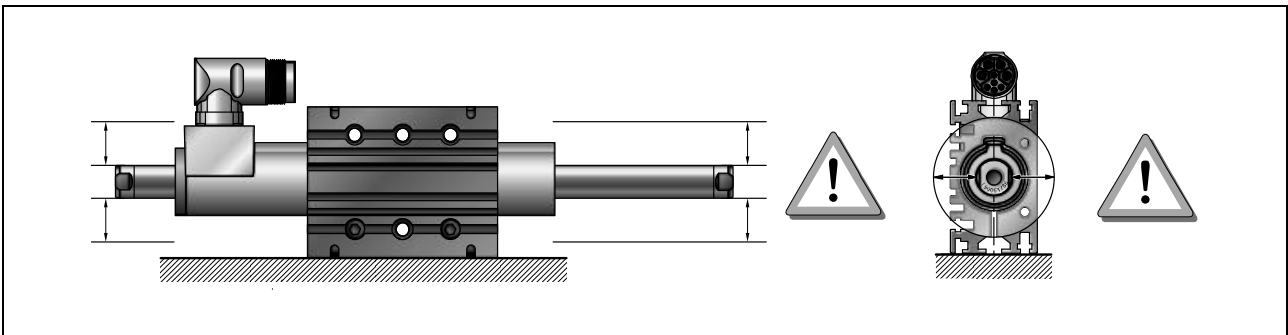

When installing linear motors in modules with metal parts near the slider, undesired forces can arise due to magnetic attraction or eddy currents. These generally manifest as erratic and jerky positioning, or reduced dynamics of the linear motor. In order to avoid this, minimum distances between the slider and any metal parts are to be observed whenever metal materials are used nearby.

Linear Motor	Minimum distance from slider surface to ferromagnetic parts (iron, steel, etc.)	Minimum distance from slider surface to non-ferromagnetic metallic parts (aluminum, bronze, stainless steel, etc.)
P10-54x...	20 mm	10 mm

4 Stroke Range

The stroke range where a constant maximum force is generated is the range where the active stator length is completely filled with drive magnets. According to the geometry, this results in a fixed start position (35 mm) and end position (23 mm) of the stroke. See the following figure.

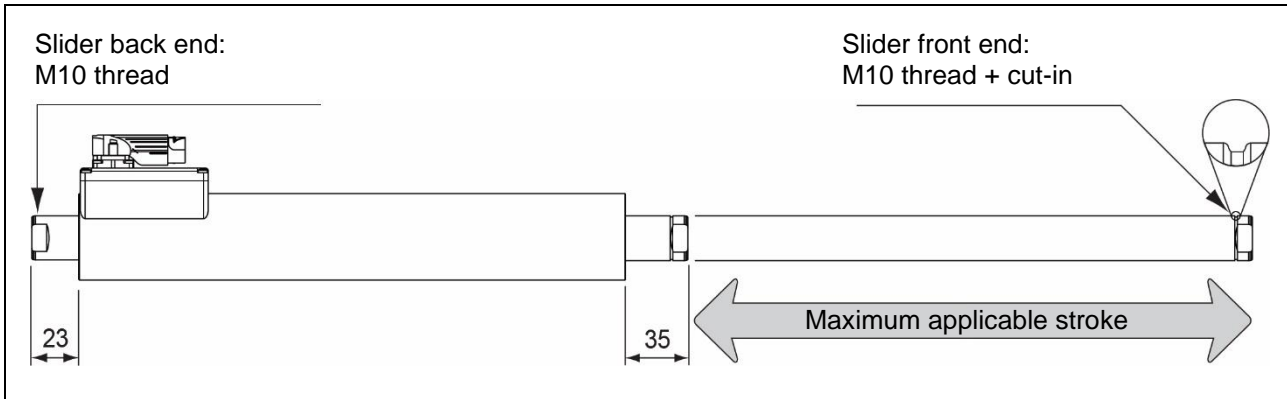

5 Electrical Connection



Do not connect or disconnect motor when there is power on the servo drive. Use only original LinMot cable. Cables from other sources must be checked precisely before commissioning. Incorrect connections can destroy the drive and stator.

5.1 Technical Data of Motor Cables

For the linear motors of the P10-54 series, different cable types are used for the power and signal supply, depending on the use of the drive type (LinMot or third-party manufacturer). All cables are high-flex cables (suitable for trailing chains) and are used for both fixed and moving applications.

	Power cable	Sensor cable	
Type	KPS07-04/02	KSS05-02/08	KSS05-02/13
Application for	LinMot drives + Third-party drives	LinMot drives	Third-party drives
Minimum bending radius for fixed installation	70 mm (2.76 in)	45 mm (1.75)	45 mm (1.75)
Minimum bending radius when moving	140 mm (5.52 in)	90 mm (3.54 in)	90 mm (3.54 in)
	No torsion	No torsion	No torsion
Max. Cable length	30 m (may be limited by Servo Drive)		
Approval	UL / CSA 1000V / 300V	UL / CSA 300V	UL / CSA 300V
Material	Wire isolation: PES Jacket: PUR	Wire isolation: TPE Jacket: Special TPU	Wire isolation: PE Jacket: PUR
Oil resistance	very good	very good	very good
Chemical resistance (to acids, alkalis, solvents, hydraulic fluid)	good	good	good
Outdoor durability	very good	very good	very good
Flammability	flame retardant	flame retardant	flame retardant

5.2 Stator connector assignment



Do not connect or disconnect motor when there is power on the servo drive.
Use only original LinMot cable. Cables from other sources must be checked precisely before commissioning.
Incorrect connections can destroy the drive and stator.

5.2.1 Power Connector

View: Motor connector, plug side

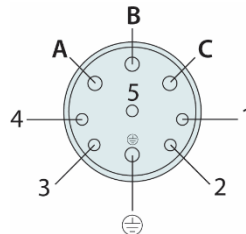

Pin	P10-54	P10-54-D04	P10-54-D05	Wire Color Motor Cable
A	Phase U	Phase U	Phase U	red
PE	PE	PE	PE	yellow-green
B	Phase V	Phase V	Phase V	blue
C	Phase W	Phase W	Phase W	black (before: green)
1	n. c.	Pt1000+ ¹⁾	PTC+ ¹⁾	cyan
2	n. c.	Pt1000- ¹⁾	PTC- ¹⁾	grey
3	n. c.	n. c.	n. c.	n. c.
4	n. c.	n. c.	n. c.	n. c.
5	n. c.	n. c.	n. c.	n. c.

Pin	P10-54-D24 P10-54-D24S	P10-54-D25 P10-54-D25S	P10-54-D26	Wire Color Motor Cable
A	Phase U	Phase U	Phase U	red
PE	PE	PE	PE	yellow-green
B	Phase V	Phase V	Phase V	blue
C	Phase W	Phase W	Phase W	black (before: green)
1	Pt1000+ ¹⁾	PTC+ ¹⁾	Do not connect	cyan
2	Pt1000- ¹⁾	PTC- ¹⁾	Do not connect	grey
3	n. c.	n. c.	n. c.	n. c.
4	n. c.	n. c.	n. c.	n. c.
5	n. c.	n. c.	n. c.	n. c.

Pin	P10-54-D34	Wire Color Motor Cable
A	Phase U	red
PE	PE	yellow-green
B	Phase V	blue
C	Phase W	black (before: green)
1	Pt1000+ ¹⁾	cyan
2	Pt1000- ¹⁾	grey
3	n. c.	n. c.
4	n. c.	n. c.
5	n. c.	n. c.

1) The temperature evaluation circuit must have the same galvanic reference potential as the encoder circuit (supply). It should therefore be connected to the supply GND. For correct evaluation, the connection potentials of the emulated temperature sensor must be in the range of the supply potentials. Valid temperature values can only be measured 50ms after the encoder supply is applied. In currentless state a resistance of 200kOhm is measured between pin 1 and 2. The maximum voltage between pin 1 and 2 must not exceed 16VDC. The maximum current is 15mA.

5.2.2 Encoder Connector

View: Motor connector, plug side

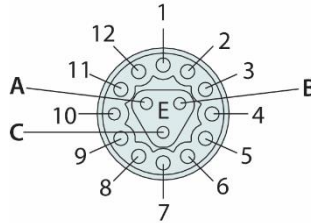

Pin	P10-54	Wire Color Motor Cable
1	+Vcc ¹⁾	red
2	GND	black
3	Sin+	yellow
4	Sin-	orange
5	Cos+	green
6	Cos-	blue
7	Motor Link C+	pink
8	Motor Link C-	grey
9	n. c.	n. c.
10	n. c.	n. c.
11	n. c.	n. c.
12	n. c.	n. c.
A	n. c.	n. c.
B	n. c.	n. c.
C	n. c.	n. c.

¹⁾ The supply voltage Vcc depends on the LinMot Drive type and is within 6...9V.

Pin	P10-54-D04	P10-54-D05	Wire Color Motor Cable
1	+Vcc	+Vcc	white
2	GND	GND	brown
3	Sin+	Sin+	grey
4	Sin-	Sin-	pink
5	Cos+	Cos+	blue
6	Cos-	Cos-	red
7	Do not connect	Do not connect	–
8	Do not connect	Do not connect	–
9	Temp+ (Pt1000 Char.) ¹⁾	Temp+ (PTC 400/20k Char.) ¹⁾	yellow-brown
10	Temp- (Pt1000 Char.) ¹⁾	Temp- (PTC 400/20k Char.) ¹⁾	white-yellow
11	Ref+	Ref+	black
12	Ref-	Ref-	violett
A	Hall U	Hall U	grey-red
B	Hall V	Hall V	red-blue

C	Hall W	Hall W	white-green
---	--------	--------	-------------

¹⁾ The temperature evaluation circuit must have the same galvanic reference potential as the encoder circuit (supply). It should therefore be connected to the supply GND. For correct evaluation, the connection potentials of the emulated temperature sensor must be in the range of the supply potentials. Valid temperature values can only be measured 50ms after the encoder supply is applied. In the currentless state, a resistance of 200kOhm is measured between pin 9 and 10 is measured. The maximum voltage between pin 9 and 10 must not exceed 16VDC. The maximum current is 15mA.

Pin	P10-70-D24 P10-70-D24S	P10-70-D25 P10-70-D25S	P10-70-D26	Wire Color Motor Cable
1	+Vcc	+Vcc	+Vcc	white
2	GND	GND	GND	brown
3	A	A	A	grey
4	/ A	/ A	/ A	pink
5	B	B	B	blue
6	/ B	/ B	/ B	red
7	Do not connect	Do not connect	Do not connect	–
8	Do not connect	Do not connect	Do not connect	–
9	Temp+ (Pt1000 Char.) ¹⁾	Temp+ (PTC 400/20k Char.) ¹⁾	Temp+ (PTC 400/20k Char.) ¹⁾	yellow-brown
10	Temp- (Pt1000 Char.) ¹⁾	Temp- (PTC 400/20k Char.) ¹⁾	Do not connect	white-yellow
11	Ref	Ref	Ref	black
12	/ Ref	/ Ref	/ Ref	violett
A	Hall U	Hall U	Hall U	grey-red
B	Hall V	Hall V	Hall V	red-blue
C	Hall W	Hall W	Hall W	white-green

¹⁾ The temperature evaluation circuit must have the same galvanic reference potential as the encoder circuit (supply). It should therefore be connected to the supply GND. For correct evaluation, the connection potentials of the emulated temperature sensor must be in the range of the supply potentials. Valid temperature values can only be measured 50ms after the encoder supply is applied. In the currentless state, a resistance of 200kOhm is measured between pin 9 and 10 is measured. The maximum voltage between pin 9 and 10 must not exceed 16VDC. The maximum current is 15mA.

Pin	P10-70-D34	Wire Color Motor Cable
1	+Vcc	white
2	GND	brown
3	SO (Slave out)	grey
4	/ SO (Slave out)	pink
5	Do not connect	–
6	Do not connect	–
7	Do not connect	–
8	Do not connect	–
9	Temp+ (Pt1000 Char.) ¹⁾	yellow-brown
10	Temp- (Pt1000 Char.) ¹⁾	white-yellow
11	MA (Master clock)	black
12	/ MA (Master clock)	violett
A	Hall U	grey-red
B	Hall V	red-blue
C	Hall W	white-green

¹⁾ The temperature evaluation circuit must have the same galvanic reference potential as the encoder circuit (supply). It should therefore be connected to the supply GND. For correct evaluation, the connection potentials of the emulated temperature sensor must be in the range of the supply potentials.

Valid temperature values can only be measured 50ms after the encoder supply is applied. In the currentless state, a resistance of 200kOhm is measured between pin 9 and 10 is measured. The maximum voltage between pin 9 and 10 must not exceed 16VDC. The maximum current is 15mA.

5.3 Attaching the cable shielding

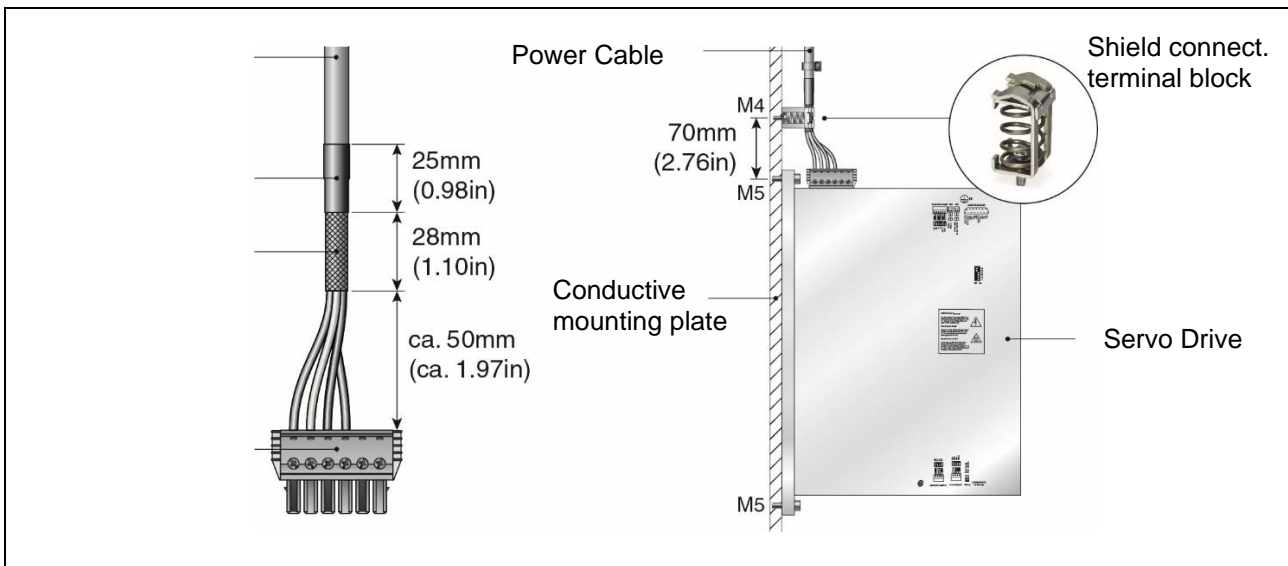

The power cable is supplied with a copper shielding (see illustration above). This prevents electrical and / or magnetic fields. The shielded part of the cable must be grounded via a connection to the back wall of the switchboard. The shielding has to be mounted holohedral to the connection part (see scheme above). The shield connection terminal block is offered as an accessory for power cables and must be ordered separately (Item-No. 0150-3631) However, the kind of attaching the cable shielding generally depends on the system of the switchboard manufacturer.

5.4 Rotatability of motor connectors

The motor connector can be rotated in both directions. (see illustration below).

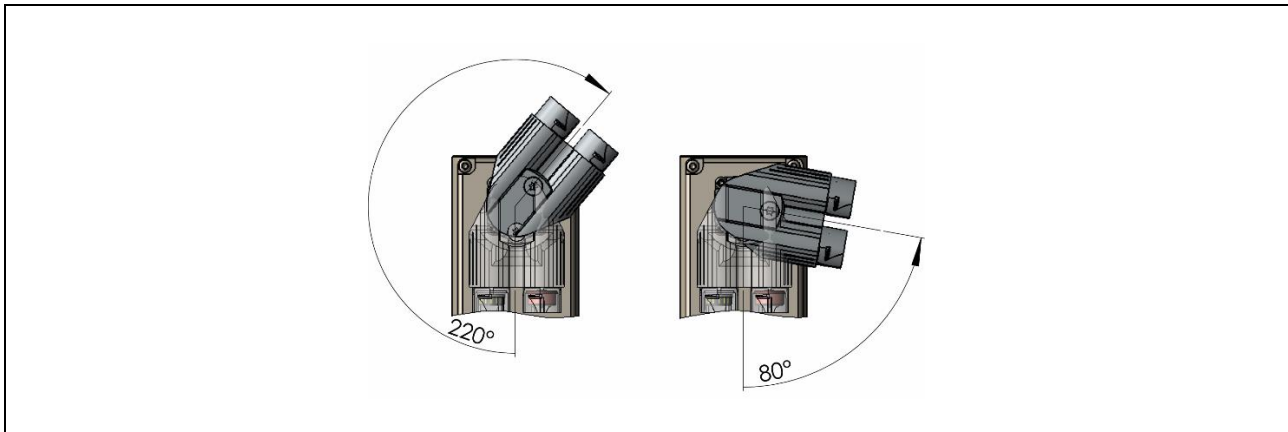

6 Accessories

6.1 Motor Cables for use with LinMot Drives

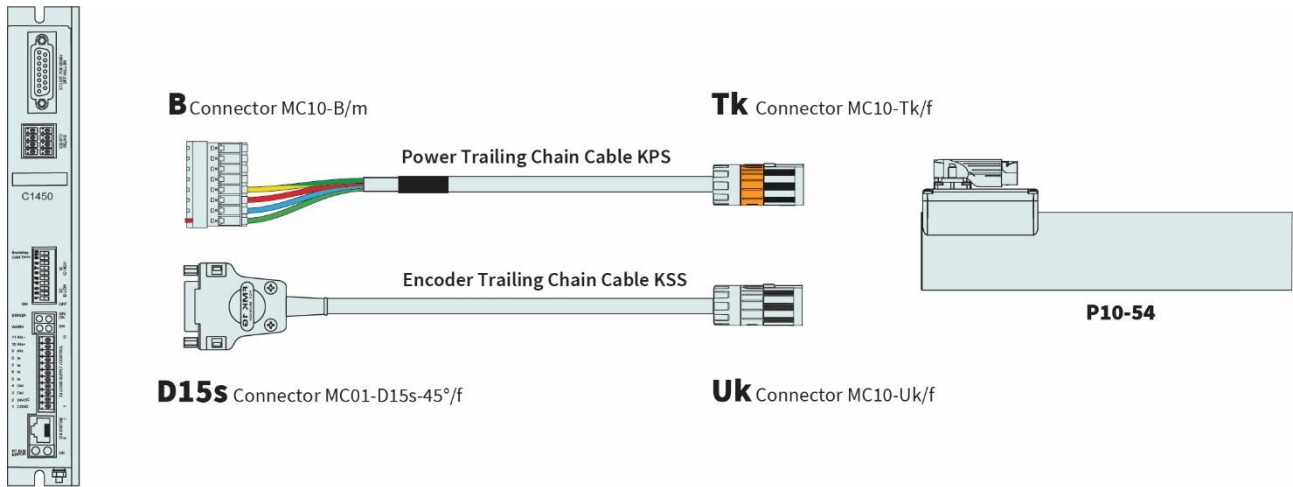

C1400

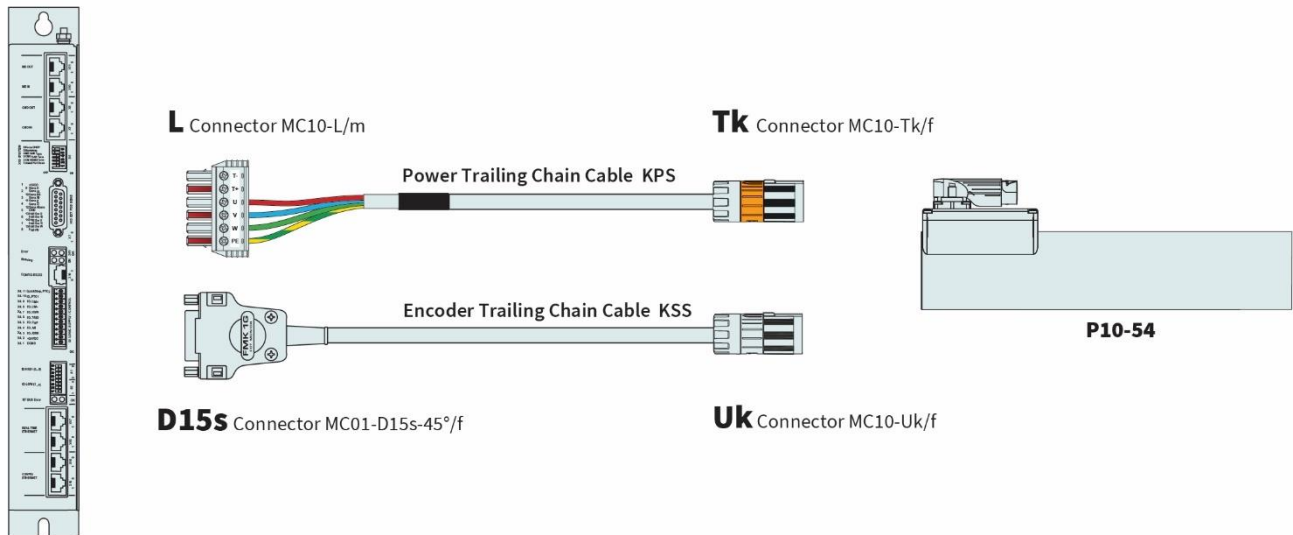

E1400

Power Cables

Item	Description	Item-No.
KPS07-04/02-B/Tk-3	Power Trailing Chain Cable C1400/P10-54, 3 m	0150-3648
KPS07-04/02-B/Tk-5	Power Trailing Chain Cable C1400/P10-54, 5 m	0150-3657
KPS07-04/02-B/Tk-8	Power Trailing Chain Cable C1400/P10-54, 8 m	0150-3658
KPS07-04/02-B/Tk-12	Power Trailing Chain Cable C1400/P10-54, 12 m	0150-3659
KPS07-04/02-B/Tk-	Power Trailing Chain Cable B/Tk-, Custom length	0150-4770

KPS07-04/02-L/Tk-3	Power Trailing Chain Cable E1400/P10-54, 3 m	0150-2670
KPS07-04/02-L/Tk-5	Power Trailing Chain Cable E1400/P10-54, 5 m	0150-2671
KPS07-04/02-L/Tk-8	Power Trailing Chain Cable E1400/P10-54, 8 m	0150-2672
KPS07-04/02-L/Tk-12	Power Trailing Chain Cable E1400/P10-54, 12 m	0150-2673
KPS07-04/02-L/Tk-	Power Trailing Chain Cable L/Tk-, Custom length	0150-3706

Encoder Cables

Item	Description	Item-No.
KSS05-02/08-D15s/Uk-3	Encoder Trailing Chain Cable D15s/Uk, 3 m	0150-2650
KSS05-02/08-D15s/Uk-5	Encoder Trailing Chain Cable D15s/Uk, 5 m	0150-2651
KSS05-02/08-D15s/Uk-8	Encoder Trailing Chain Cable D15s/Uk, 8 m	0150-2652
KSS05-02/08-D15s/Uk-12	Encoder Trailing Chain Cable D15s/Uk, 12 m	0150-2653
KSS05-02/08-D15s(f)-45°/Uk-	Encoder Trailing Chain Cable D15s(f)-45°/Uk-, Custom length	0150-2731

Extension Cables

Item	Description	Item-No.
KPS07-04/02-Tk/Tk-	Power Trailing Chain Cable Tk/Tk-, Custom length	0150-2829
KSS05-02/08-Uk/Uk	Encoder Trailing Chain Cable Uk/Uk-, Custom length	0150-2830

Connectors

Item	Description	Item-No.
MC10-L/m	Connector Power E1400/X2	0150-3382
MC01-D15/f	Motor Connector D15 (f)	0150-3136
MC10-Tk/f	Connector Power PS10-54	0150-3482
MC10-Uk/f	Connector Encoder PS10-54	0150-3483

6.2 Motor Cables for use with third-party Drives

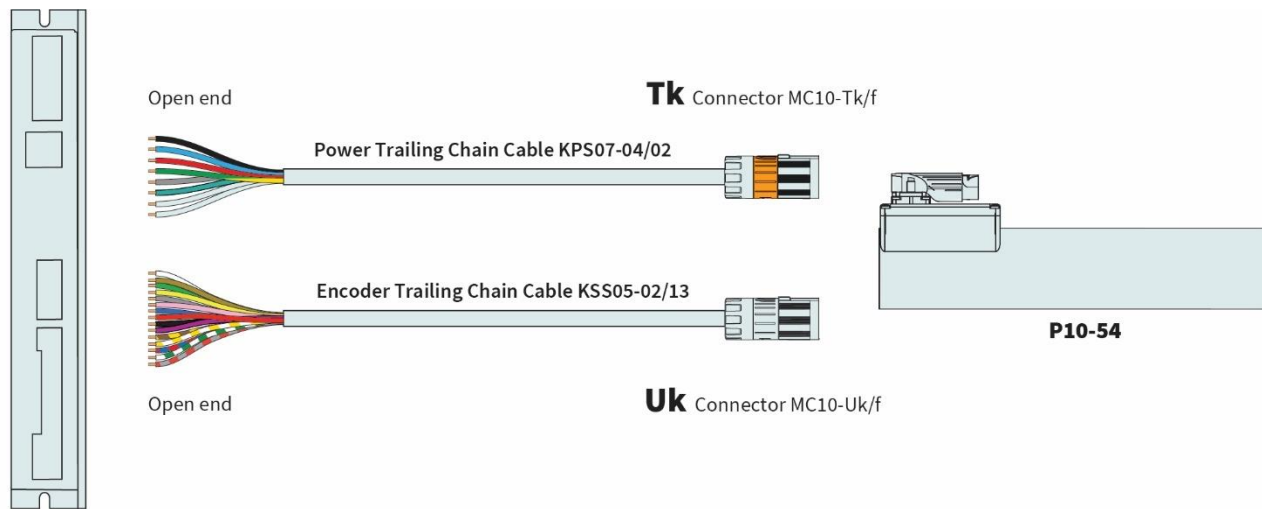

3rd party Drive

Power Cables

Item	Description	Item-No.
KPS07-04/02-./Tk-10	Power Trailing Chain Cable .../Tk, 10m	0150-3626
KPS07-04/02-./Tk-	Power Trailing Chain Cable .../Tk, Custom length	0150-3622
KPS07-04/02	Power Trailing Chain Cable P10-54 (per m)	0150-2372

Encoder Cables

Item	Description	Item-No.
KSS05-02/13-./Uk-10	Encoder Trailing Chain Cable ./Uk, 10m	0150-3627
KSS05-02/13-./Uk-	Encoder Trailing Chain Cable ./Uk, Custom length	0150-3619
KSS05-02/13	Encoder Trailing Chain Cable P10-...-Dxx (per m)	0150-2259

Extension Cables

Item	Description	Item-No.
KPS07-04/02-Tk/Tk-	Power Trailing Chain Cable Tk/Tk-, Custom length	0150-2829
KSS05-02/08-Uk/Uk	Encoder Trailing Chain Cable Uk/Uk-, Custom length	0150-2830

Connectors

Item	Description	Item-No.
MC10-Tk/f	Connector Power PS10-54	0150-3482
MC10-Uk/f	Connector Encoder PS10-54	0150-3483

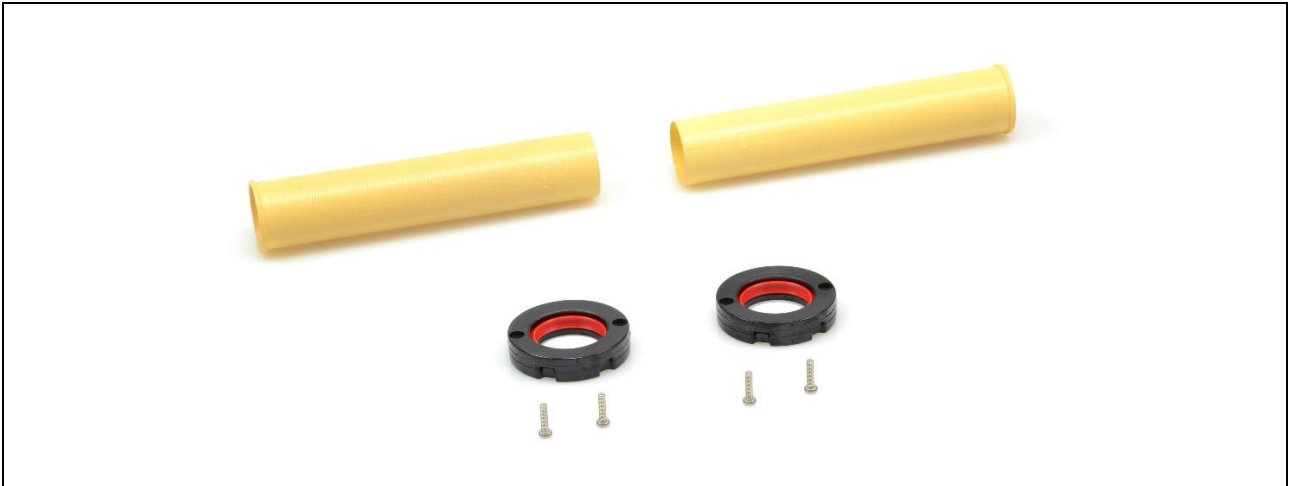
6.3 Bearing kit

The stators are equipped with a removable bearing set as standard. This consists of 1 or 2 removable bearing bushings and 2 end pieces with wipers. By the use of the wipers maintenance and the maintenance cycles can be extended. It also effects that the lubricant is dispensed metered and does not leak outside of the stator. The lubricant is less dirty.

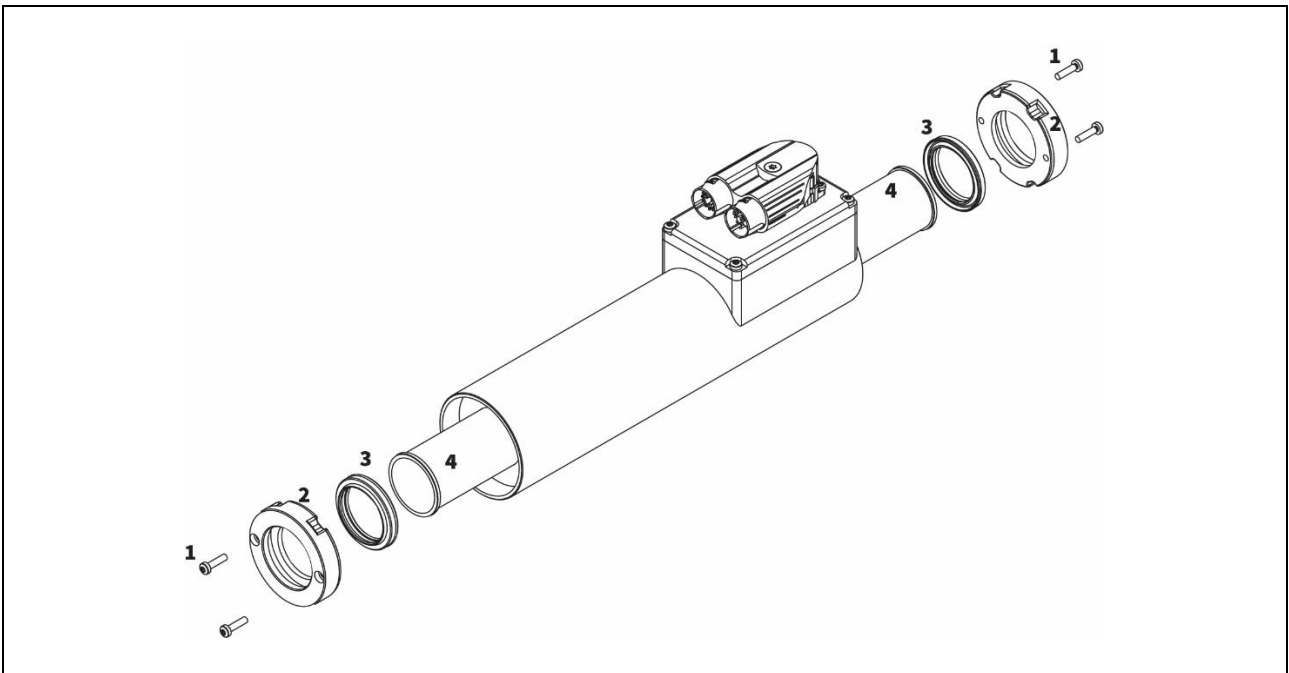
6.3.1 Overview

Pos. 1: Pan head screw stainless steel; Pos. 2: Stator end piece; Pos. 3: Wiper; Pos. 4: Bearing bushing

Ordering information

Item	Description	Item-No.
PB10-54x120-L	Bearing kit for PS10-54x120	0150-3671
PB10-54x180-L	Bearing kit for PS10-54x180	0150-3672
PB10-54x240-L	Bearing kit for PS10-54x240	0150-3673
PB10-54x300-L	Bearing kit for PS10-54x300	0150-3674

6.3.2 Mounting

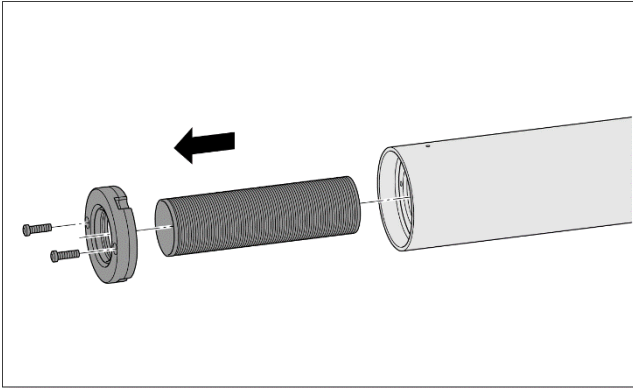

1. Dismounting front bearing set

Remove the end piece and the bearing bushing at the front end of the stator.

Note! With the stator P10-54x120 there is only 1 bearing bushing for the whole length.

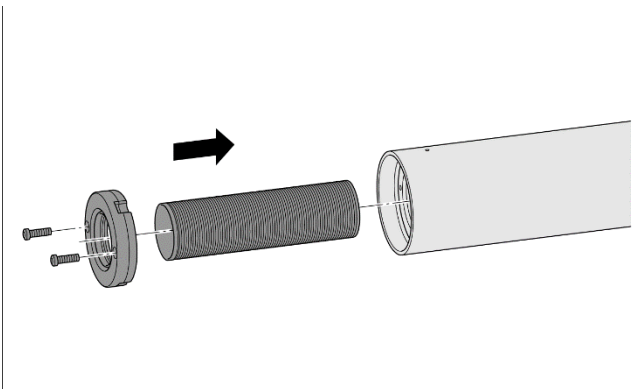

2. Mounting front bearing set

The bearing bushing is pushed in as far as it will go. Then screw the end piece together with the 2 pan-head screws.

Tightening torque: 1.2 Nm

The pan-head screws are already coated with Tuflok.

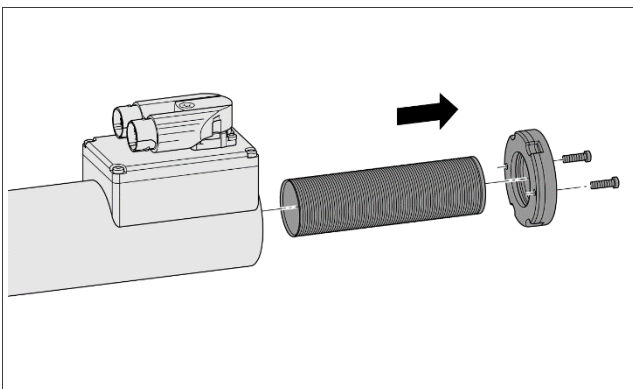

3. Dismounting rear bearing set

Remove the end piece and the bearing bushing at the front end of the stator.

Note! With the stator P10-54x120 there is only 1 bearing bushing for the whole length.

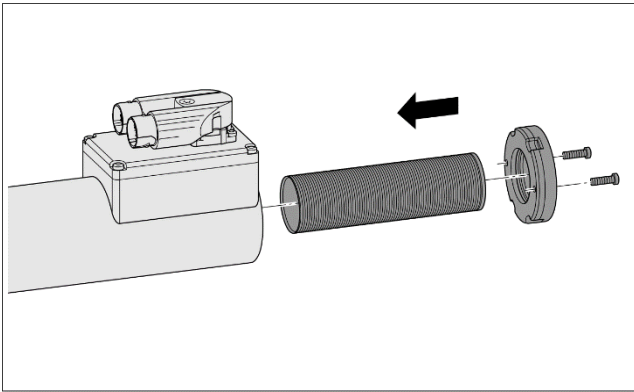

4. Mounting rear bearing set

The bearing bushing is pushed in as far as it will go. Then screw the end piece together with the 2 pan-head screws.

Tightening torque: 1.2 Nm

The pan-head screws are already coated with Tuflok.

6.4 Mounting flanges

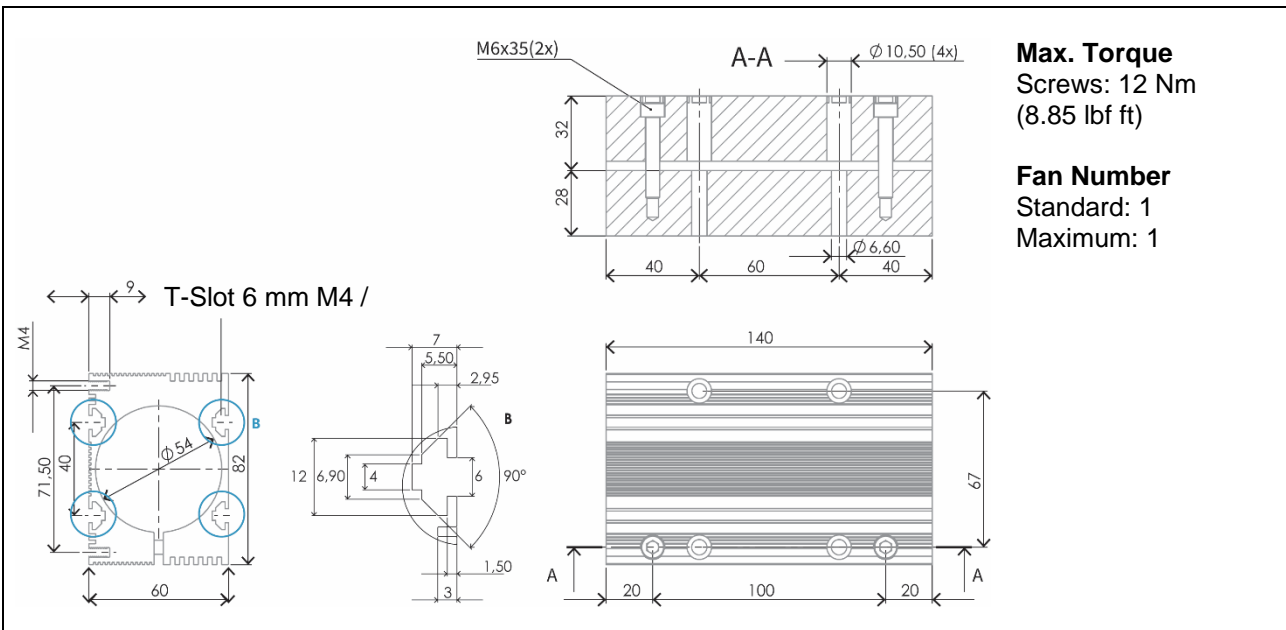

Max. Torque
Screws: 12 Nm
(8.85 lbf ft)

Fan Number
Standard: 1
Maximum: 1

Item	Description	Weight [g]	Item-No.
PF10-54x140	Flange for PS10-54x120	781	0150-2733

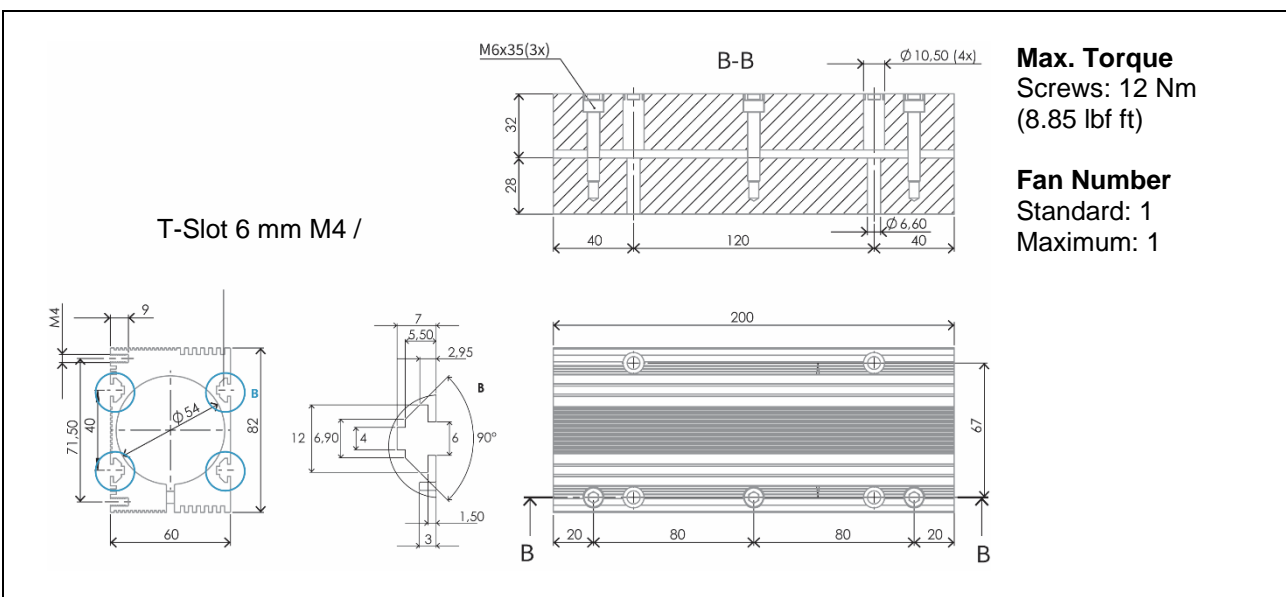

Max. Torque
Screws: 12 Nm
(8.85 lbf ft)

Fan Number
Standard: 1
Maximum: 1

Item	Description	Weight [g]	Item-No.
PF10-54x200	Flange for PS10-54x180	1132	0150-2734

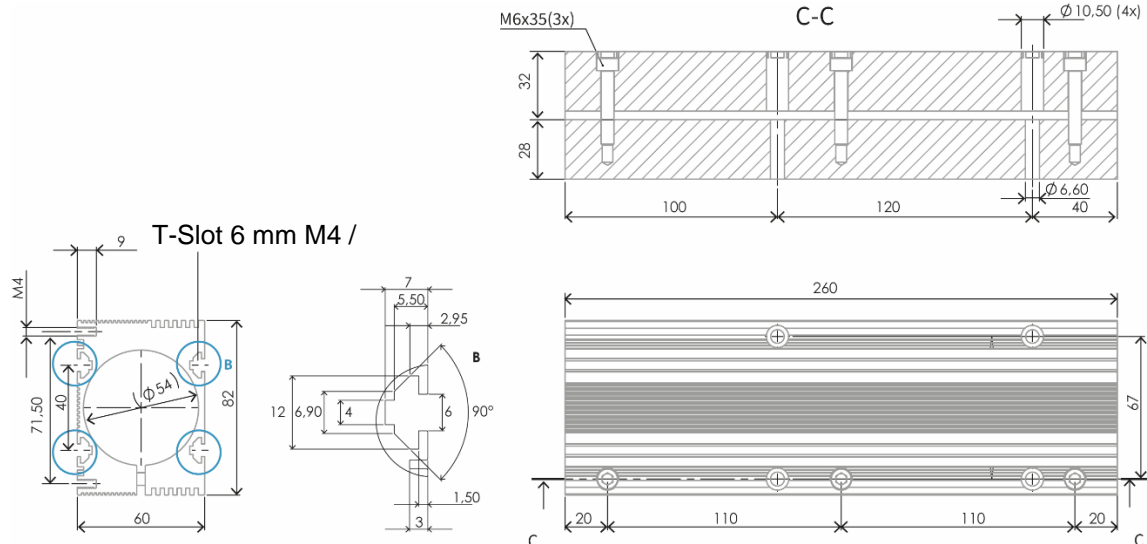

Max. Torque
Screws: 12 Nm (8.85 lbf ft)

Fan Number
Standard: 1
Maximum: 2

Item	Description	Weight [g]	Item-No.
PF10-54x260	Flange for PS10-54x240	1475	0150-2735

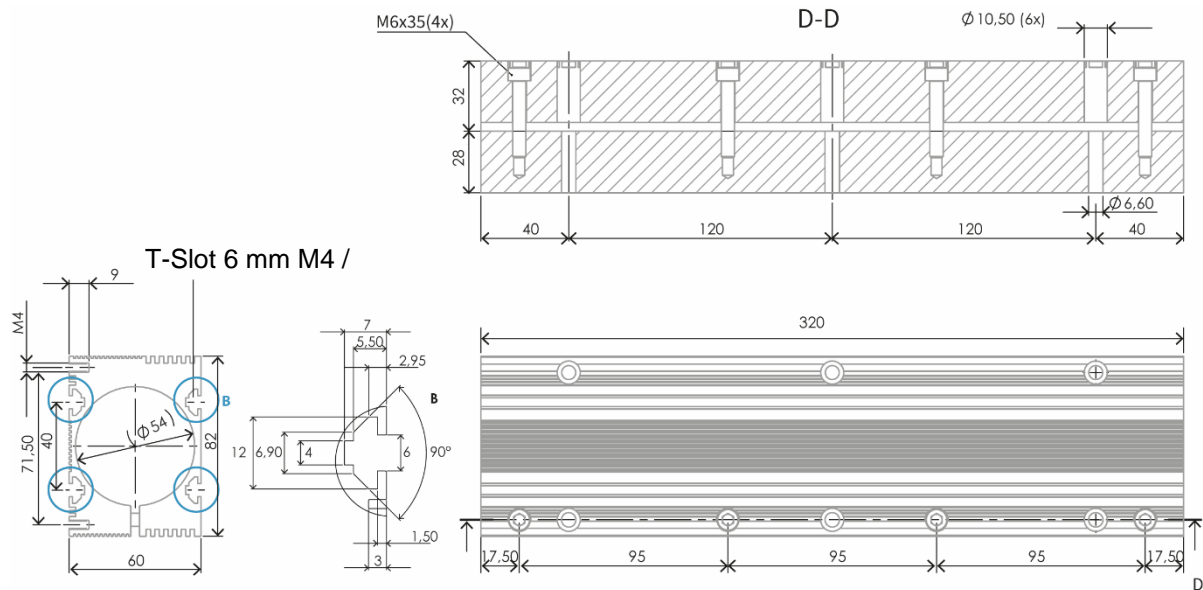

Max. Torque
Screws: 12 Nm (8.85 lbf ft)

Fan Number
Standard: 2
Maximum: 2

Item	Description	Weight [g]	Item-No.
PF10-54x320	Flange for PS10-54x300	1809	0150-2736

6.5 Fan kits for flanges

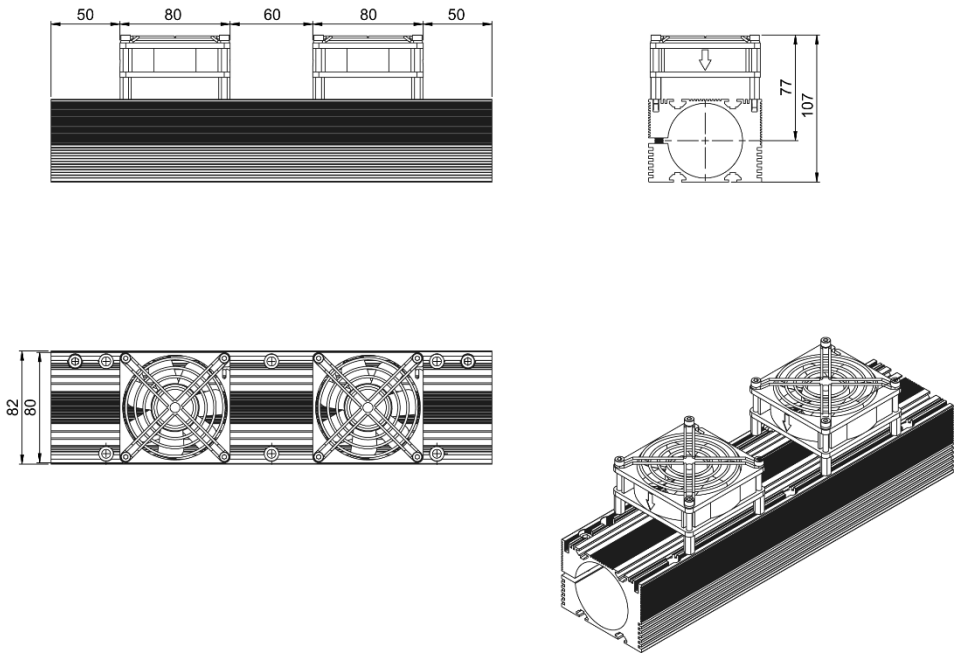

Power Supply Fan
24 VDC, 120 mA

Air flow
80 m³ / h

Item	Description	Item-No.
HV01-37 / 48	Fan Kit for H01-37 / 48 and PF02-37 / 48 composed of: 1 x Fan, 4 x cylinder screw M4 x 30, 4 x square nut M4, 4 x spacer M4 x 16	0150-5051

6.6 Slider mounting kits

6.6.1 Fixed bearing

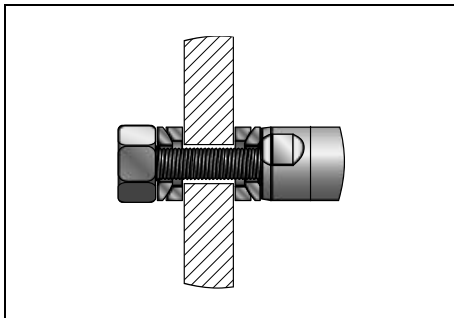

Slider mounting kit consists of a spring washer, a pair of spherical washers, and a pair of conical seats. It allows the slider to be fixed in the direction of motion. It also helps to compensate for radial and angle offset.

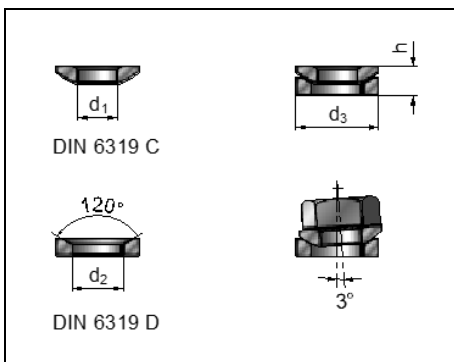

Material

Spherical washer / conical seat: case hardened steel

Item	Item No.	Slider	Thread	d1	d2	d3	h
PLF01-28	0150-3087	28mm	M10	10.5mm (0.41in)	12mm (0.47in)	21mm (0.83in)	6.5mm (0.26in)

PLF01-28 (Stainless-st.)	0150-3297	28mm	M10	10.5mm (0.41in)	12mm (0.47in)	21mm (0.83in)	6.5mm (0.26in)
-----------------------------	-----------	------	-----	--------------------	------------------	------------------	-------------------

6.6.2 Floating bearing

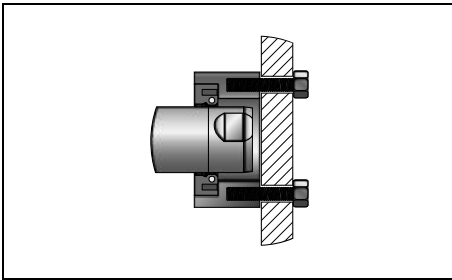

Floating bearing assembly that permits radial adjustment of slider position and permits a small amount of radial and axial movement.

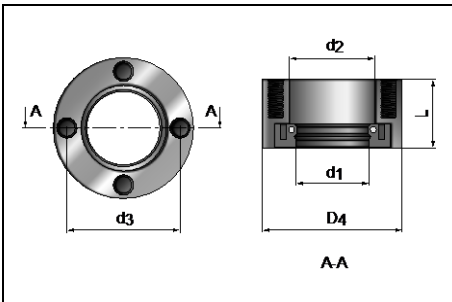

Material
 Housing: Stainless steel 1.4305
 Bearing: Nitrile butadiene rubber
 Spring steel DIN17223

Item	Item No.	Slider	Thread	d1	d2	d3	D4	L
PLL01-28	0150-3094	28mm	M5	28mm (1.10in)	32mm (1.26in)	40mm (1.57in)	48mm (1.89in)	20mm (0.79in)

6.6.3 Complete mounting kit

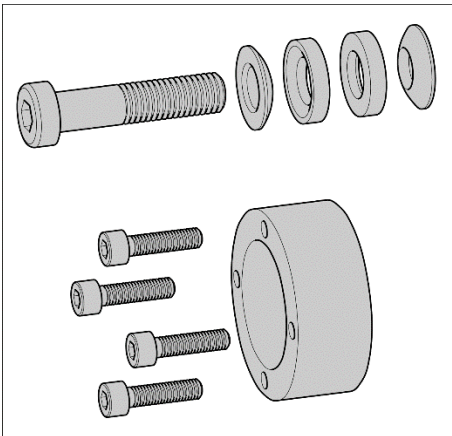

This kit provides one set of mounting parts for each end of the slider.

Ordering information

Item	Description	Item-No.
PLM01-28-MK	Mounting kit for PL01-28 slider composed of: 1 Spherical washer & conical seat (0150-3087) 1 Floating Bearing (0150-3094) 1 Socket hd. cap screw * DIN 912 / M10, L=35 mm (L=1.38 in) 4 Socket hd. cap screw * DIN 912 / M5, L=20 mm (L=0.78 in)	0150-3095

* For use with 12 mm (1/2 in) thick mounting plates.

7 Maintenance and test instructions

7.1 Stator checking

The following tables show the resistive value between the different connector pins for each stator type. If the value is not within a range of +/- 10% the stator may be damaged (temperature of the stator for all measurements: 25°C).

PS10-54x120U-...

...-BL-TU (0150-2722)

...-BL-TU-D24 (0150-2748)

...-BL-TU-D25S (0150-2782)

...-BL-TU-D04 (0150-4408)

...-BL-TU-D24S (0150-4048)

...-BL-TU-D26 (0150-2955)

...-BL-TU-D05 (0150-4591)

...-BL-TU-D25 (0150-2752)

...-BL-TU-D34 (0150-5770)

Phase U / Phase V	Pin A / Pin B	14 Ω @ 25 °C
Phase V / Phase W	Pin B / Pin C	14 Ω @ 25 °C
Phase W / Phase U	Pin C / Pin A	14 Ω @ 25 °C
Casing	Any phases / Casing	> 200 MΩ @ 25 °C
Temp + / Temp -	Pin 1 / Pin 2 (for power connector) Pin 9 / Pin 10 (for encoder connector)	200 kΩ @ 25 °C (supply off)

PS10-54x180U-...

...-BL-TU (0150-2723)

...-BL-TU-D24 (0150-2749)

...-BL-TU-D25S (0150-2783)

...-BL-TU-D04 (0150-4409)

...-BL-TU-D24S (0150-4049)

...-BL-TU-D26 (0150-2956)

...-BL-TU-D05 (0150-4592)

...-BL-TU-D25 (0150-2753)

...-BL-TU-D34 (0150-5771)

Phase U / Phase V	Pin A / Pin B	5.7 Ω @ 25 °C
Phase V / Phase W	Pin B / Pin C	5.7 Ω @ 25 °C
Phase W / Phase U	Pin C / Pin A	5.7 Ω @ 25 °C
Casing	Any phases / Casing	> 200 MΩ @ 25 °C
Temp + / Temp -	Pin 1 / Pin 2 (for power connector) Pin 9 / Pin 10 (for encoder connector)	200 kΩ @ 25 °C (supply off)

PS10-54x240U-...

...-BL-TU (0150-2724)

...-BL-TU-D24 (0150-2750)

...-BL-TU-D25S (0150-2784)

...-BL-TU-D04 (0150-4410)

...-BL-TU-D24S (0150-4050)

...-BL-TU-D26 (0150-2957)

...-BL-TU-D05 (0150-4593)

...-BL-TU-D25 (0150-2754)

...-BL-TU-D34 (0150-5772)

Phase U / Phase V	Pin A / Pin B	7.5 Ω @ 25 °C
Phase V / Phase W	Pin B / Pin C	7.5 Ω @ 25 °C
Phase W / Phase U	Pin C / Pin A	7.5 Ω @ 25 °C
Casing	Any phases / Casing	> 200 MΩ @ 25 °C
Temp + / Temp -	Pin 1 / Pin 2 (for power connector) Pin 9 / Pin 10 (for encoder connector)	200 kΩ @ 25 °C (supply off)

PS10-54x300U-...

...-BL-TU (0150-2725)

...-BL-TU-D24 (0150-2751)

...-BL-TU-D25S (0150-2785)

...-BL-TU-D04 (0150-4411)

...-BL-TU-D24S (0150-4051)

...-BL-TU-D26 (0150-2958)

...-BL-TU-D05 (0150-4594)

...-BL-TU-D25 (0150-2755)

...-BL-TU-D34 (0150-5773)

Phase U / Phase V	Pin A / Pin B	5.7 Ω @ 25 °C
Phase V / Phase W	Pin B / Pin C	5.7 Ω @ 25 °C
Phase W / Phase U	Pin C / Pin A	5.7 Ω @ 25 °C
Casing	Any phases / Casing	> 200 MΩ @ 25 °C
Temp + / Temp -	Pin 1 / Pin 2 (for power connector) Pin 9 / Pin 10 (for encoder connector)	200 kΩ @ 25 °C (supply off)



* Temperature resistances can only be correctly set with active sensor power supply. (emulated temperature resistance).

7.2 Maintenance of linear motors

The stators will be shipped with an initial lubrication. Maintenance will only be required if the motors run 'dry' or there is a heavy pollution of the motors. Under normal industrial conditions (5 day, 8 h / day) one inspection every 3 months is adequate. The inspection cycle must be shortened if severe motor loads or deviating conditions exist. These conditions are for example:

- Permanent fouling
- Direct sunshine
- Low Humidity
- Outdoor operation
- Increased operating temperature

7.2.1 Mounting

Sliders with a length ≤ 500 mm (20 in) are to be inserted in a clean condition in the stator. Sliders with a length > 500 mm (20 in) must be lubricated with LU02. 4 g of lubricant per meter slider is enough to create a film of lubricant on the surface of the sliders. 4 g (0.14 oz) is about $\frac{1}{2}$ of a hazel-nut. The grease can be applied by hand or with a soft paper towel. If wipers are used then the inner side of the seals of the wipers must be lubricated as well.



Basically, it must be ensured that only a thin film of grease is applied. 4 g of grease per 1000 mm of slider length is sufficient for this purpose. Over lubrication leads to a gumming of the grease, which appears particularly at higher operating temperatures! In this case, a complete cleaning of the motor has to be made.

7.2.2 Inspection

Inspections have to be executed according to the operating condition and the load of motors. Following points have to be checked during inspection:

- a) Is a film of lubricant on the slider? If not -> Lubrication
- b) Is the wiper (if existent) without visible wear? If not -> Replace wipers
- c) Is the lubricant homogeneous and not decomposed? In case of negation -> Cleaning (stator, slider) + Lubrication
- d) Can the slider be moved easily? If not -> Cleaning (stator, slider) + Lubrication

7.2.3 Cleaning

- Pull the sliders carefully out of the stator.
Attention! Strong magnetic attraction forces (note safety instructions on page 5)!
Use non magnetic material (e.g. wood) to cover close-by iron constructions.
- Clean slider and stator with a soft disposable paper, ideally with the help of LU06 cleaning spray (or methylated spirits or alcohol).
- Afterwards, lubricate the bore of the stators with about 2-3 g (0.1 oz) grease LU02.
There should only be a slight film of lubricant.
Note: Do not over lubricate!
- Finally, slider should be lubricated according to the chapter 'mounting'.

7.2.4 Cleaning agent / Lubricant

For the cleaning of LinMot stators and sliders cleaning agent spray LU06 is recommended. To improve the sliding characteristics between the stainless steel surface of the slider and the plastic slide bearing the LinMot lubricant LU02 is prescribed.

Ordering information

Item	Description	Item-No.
LU06-250	Klüberfood NH1 4-002 Spray* (250 ml)	0150-2394
LU02-08	Lubricant for linear motors ** (8 g)	0150-1953
LU02-50	Lubricant for linear motors ** (50 g)	0150-1954

LU02-1000	Lubricant for linear motors ** (1000 g)	0150-1955
-----------	---	-----------

* LinMot Spray LU06 corresponds to KLÜBERFOOD NH1 4-002 which was developed for the food processing industry.

** LinMot LU02 Lubricant corresponds to KLÜBERSYNTH UH1 14-31 which was developed for the food processing industry.

8 Storage, transport, installation altitude

- Sliders are to be stored and transported only in the plastic containers (with cardboard inlay) provided for this purpose, or already installed and secured in LinMot P stators.
- Remove the slider from this plastic containers only for assembling.
- The storage area must be dry, dust-free, frost-free and vibration-free.
- The relative air humidity should be less than 60 %.
- Prescribed storage temperature: -15 °C...70 °C
- The motor must be protected against extreme weather conditions.
- The air in the storage area must not contain any harmful gases.
- The max. installation altitude is 2'000 m (for higher values contact LinMot) above sea level.
- From 1'000 m, derating of 1 °C per 100 m is to be considered for air cooling.

9 Dimensions

9.1 Stator

9.1.1 PS10-54x120

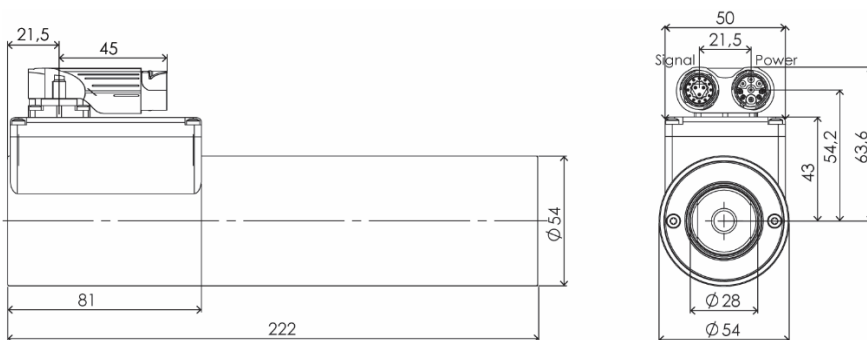

9.1.2 PS10-54x180

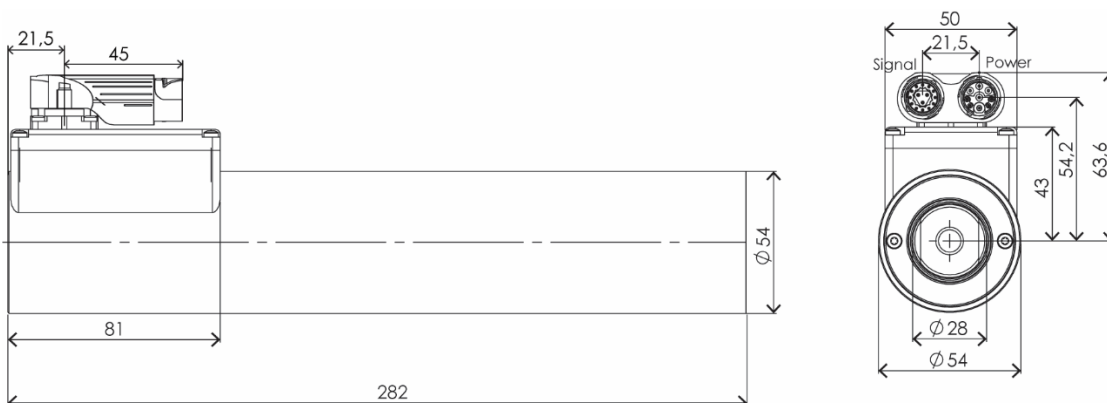

9.1.3 PS10-54x240

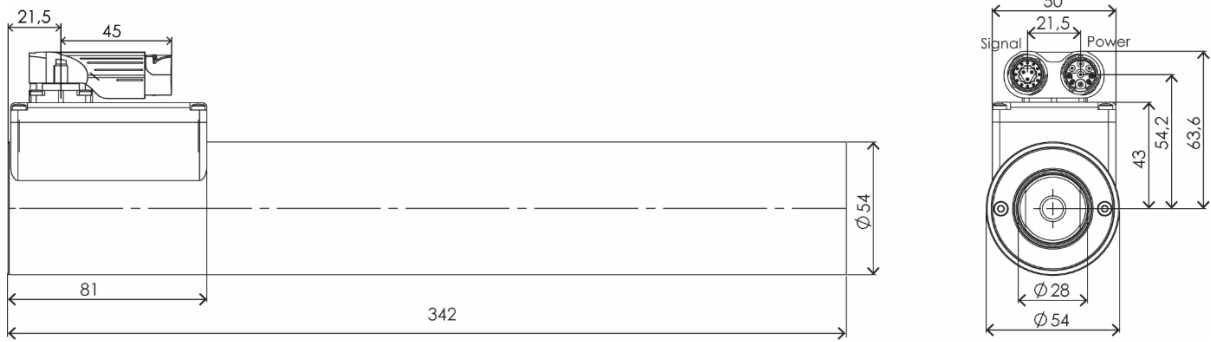

9.1.4 PS10-54x300

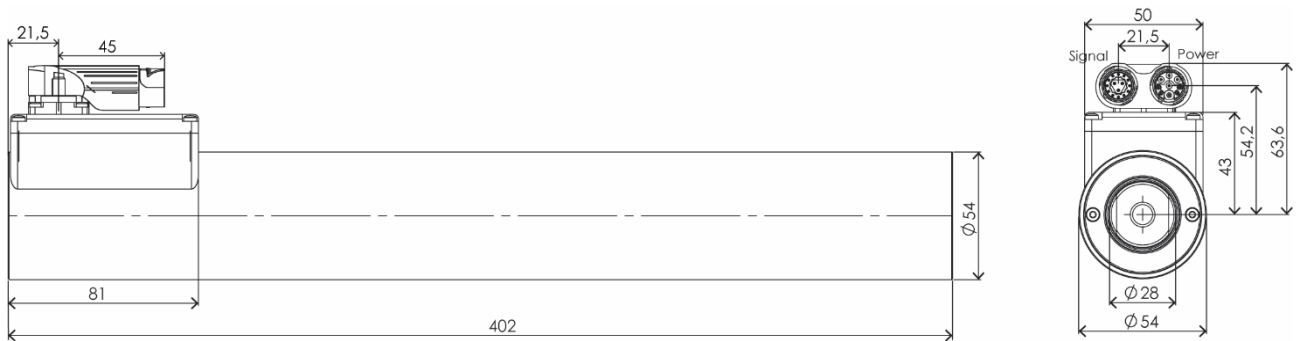

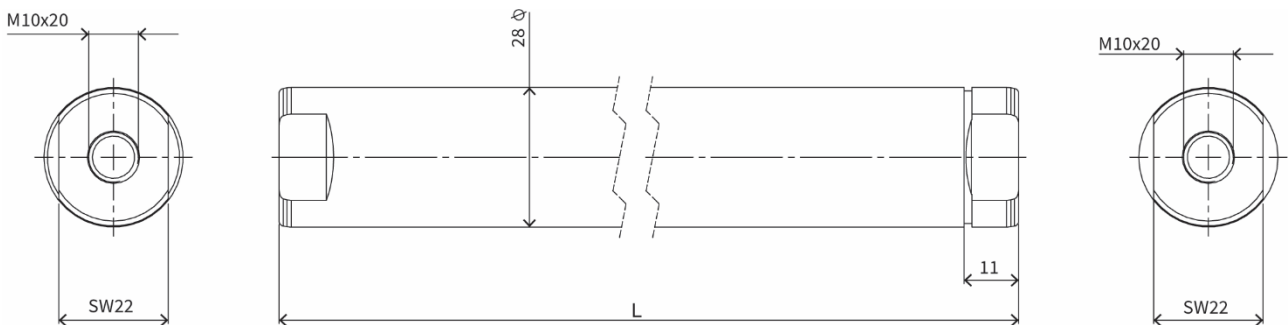

9.2 Slider



Item	Item-No.	Length L [mm / in]
PL01-28x350/270	0150-1380	350 / 13.78
PL01-28x410/330	0150-1381	410 / 16.14
PL01-28x500/420	0150-1382	500 / 19.69
PL01-28x620/540	0150-1383	620 / 24.4
PL01-28x710/630	0150-1384	710 / 27.95
PL01-28x800/720	0150-1385	800 / 31.5
PL01-28x920/840	0150-1386	920 / 36.22
PL01-28x1010/930	0150-1387	1010 / 39.76
PL01-28x1220/1140	0150-1388	1220 / 48.03
PL01-28x1400/1320	0150-1389	1400 / 55.12
PL01-28x1610/1530	0150-1390	1610 / 63.39
PL01-28x1820/1740	0150-1395	1820 / 71.65
PL01-28x2000/1920	0150-1396	2000 / 78.74

10 International Certificates

<p>Europe</p> 	<p>See chapter "EU Declaration of Conformity CE-Marking"</p>
<p>UK</p> 	<p>See chapter "UK Declaration of Conformity UKCA-Marking"</p>
<p>IECEE CB SCHEME</p>	<p>Ref. Certif. Nr. CH-8521</p>
<p>USA / Canada</p> 	<p>File Number E354430 Refers to cURus marked motors</p>

	Ref. Certif. No.
	CH-8521



IEC SYSTEM FOR MUTUAL RECOGNITION OF TEST CERTIFICATES FOR ELECTRICAL EQUIPMENT (IECEE) CB SCHEME

CB TEST CERTIFICATE

Product	Linear motor	
Name and address of the applicant	NTI AG	Bodenäckerstrasse 2 SWITZERLAND 8957 Spreitenbach
Name and address of the manufacturer	NTI AG	Bodenäckerstrasse 2 SWITZERLAND 8957 Spreitenbach
Name and address of the factory	NTI AG	Bodenäckerstrasse 2 SWITZERLAND 8957 Spreitenbach
<i>Note: When more than one factory, please report on page 2</i>	<input type="checkbox"/> Additional Information on page 2	
Ratings and principal characteristics	supplied via servo drive, see TR 17-EL-0006.E02 for details	
Trade mark (if any)	LinMot	
Customers's Testing Facility (CTF) Stage used	---	
Model / Type Ref.	PR series PS series P04 series P05 series	
Additional information (if necessary may also be reported on page 2)	---	
A sample of product was tested and found to be in conformity with IEC	<input type="checkbox"/> Additional Information on page 2 IEC 61000-6-2:2016 IEC 61000-6-4:2006, IEC 61000-6-4:2006/AMD1:2010 IEC 61000-6-7:2014	
National differences	EU Group Differences; EU Special National Conditions; EU A-Deviations	
As shown in the Test Report Ref. No. which forms part of this Certificate	17-EL-0006.E01 + .E02 + .Z01	



This CB Test Certificate is issued by the National Certification Body

Electrosuisse Luppenstrasse 1 8320 Fehraltorf SWITZERLAND		
Signed by: Martin Plüss Date: 2017-03-13		page 1 of 1

CERTIFICATE OF COMPLIANCE

Certificate Number 20181203-E354430
Report Reference E354430-20150125
Issue Date 2018-DECEMBER-03

Issued to: NTI AG
Bodenaeckerstr 2
8957 SPREITENBACH SWITZERLAND

This certificate confirms that representative samples of COMPONENT - INCOMPLETE ROTATING MACHINES AND ROTATING MACHINE PARTS
See Addendum Page for Models/Product

Have been investigated by UL in accordance with the component requirements in the Standard(s) indicated on this Certificate. UL Recognized components are incomplete in certain constructional features or restricted in performance capabilities and are intended for installation in complete equipment submitted for investigation to UL LLC.

Standard(s) for Safety: UL 1004-1 - Rotating Electrical Machines- General Requirements .
CSA C22.2 No.100 - Motors and Generators

Additional Information: See the UL Online Certifications Directory at <https://iq.ulprospector.com> for additional information.

This *Certificate of Compliance* does not provide authorization to apply the UL Recognized Component Mark.

Only those products bearing the UL Recognized Component Mark should be considered as being UL Certified and covered under UL's Follow-Up Services.

Look for the UL Recognized Component Mark on the product.



Bruce Mahrenholz, Director North American Certification Program
UL LLC

Any information and documentation involving UL Mark services are provided on behalf of UL LLC (UL) or any authorized licensee of UL. For questions, please contact a local UL Customer Service Representative at <http://ul.com/aboutul/locations>.



CERTIFICATE OF COMPLIANCE

Certificate Number 20181203-E354430
Report Reference E354430-20150125
Issue Date 2018-DECEMBER-03

This is to certify that representative samples of the product as specified on this certificate were tested according to the current UL requirements.

USR, CNR – Recognized Component – Class A Insulated Linear Motor models tabulated below intended for use with a 3 phase frequency converter only.-

Model P10-70, PS10-70, & P10-54, PS10-54



Bruce Mahrenholz, Director North American Certification Program
UL LLC

Any information and documentation involving UL Mark services are provided on behalf of UL LLC (UL) or any authorized licensee of UL. For questions, please contact a local UL Customer Service Representative at <http://ul.com/aboutul/locations>.



11 EU Declaration of Conformity CE-Marking

NTI AG / LinMot ®
Bodenaeckerstrasse 2
8957 Spreitenbach

Switzerland

Tel.: +41 (0)56 419 91 91

Fax: +41 (0)56 419 91 92

declares under sole responsibility the compliance of the products:

- Linear Motors of the Series **PS10-54xxx-xx-xx**
- Linear Motors of the Series **PS10-54xxx-xx-xx-D04**
- Linear Motors of the Series **PS10-54xxx-xx-xx-D05**
- Linear Motors of the Series **PS10-54xxx-xx-xx-D24**
- Linear Motors of the Series **PS10-54xxx-xx-xx-D24S**
- Linear Motors of the Series **PS10-54xxx-xx-xx-D25**
- Linear Motors of the Series **PS10-54xxx-xx-xx-D25S**
- Linear Motors of the Series **PS10-54xxx-xx-xx-D26**
- Linear Motors of the Series **PS10-54xxx-xx-xx-D34**

with the Low Voltage Directive 2014/35/EU 2014/35/EU.

Applied harmonized standards:

- **EN 61800-5-1: 2007**

with the EMC Directive 2014/30/EU.

Applied harmonized standards:

- **EN 61000-6-2: 2005 (Immunity for industrial environments)**
- **EN 61000-6-4: 2007 (Emission for industrial environments)**

According to the EMC directive, the listed devices are not independently operable products.

Compliance of the directive requires the correct installation of the product, the observance of specific installation guides and product documentation. This was tested on specific system configurations.

The safety instructions of the manuals are to be considered.

The product must be mounted and used in strict accordance with the installation instructions contained within the installation guide, a copy of which may be obtained from NTI AG.

Company: NTI AG
Spreitenbach, 23.02.2023



Dr.-Ing. Ronald Rohner
CEO NTI AG

12 UK Declaration of Conformity UKCA-Marking

NTI AG / LinMot®
Bodenaeckerstrasse 2
8957 Spreitenbach

Switzerland

Tel.: +41 (0)56 419 91 91

Fax: +41 (0)56 419 91 92

declares under sole responsibility the compliance of the products:

- Linear Motors of the Series **PS10-54xxx-xx-xx**
- Linear Motors of the Series **PS10-54xxx-xx-xx-D04**
- Linear Motors of the Series **PS10-54xxx-xx-xx-D05**
- Linear Motors of the Series **PS10-54xxx-xx-xx-D24**
- Linear Motors of the Series **PS10-54xxx-xx-xx-D24S**
- Linear Motors of the Series **PS10-54xxx-xx-xx-D25**
- Linear Motors of the Series **PS10-54xxx-xx-xx-D25S**
- Linear Motors of the Series **PS10-54xxx-xx-xx-D26**
- Linear Motors of the Series **PS10-54xxx-xx-xx-D34**

with the Electrical Equipment (Safety) Regulations 2016 SI 2016 No. 1101

Applied designated standards:

- **EN 61800-5-1: 2007**

with the EMC Regulation S.I. 2016 No. 1091.

Applied designated standards:

- **EN 61000-6-2: 2005 (Immunity for industrial environments)**
- **EN 61000-6-4: 2007 (Emission for industrial environments)**

According to the EMC regulation, the listed devices are not independently operable products.

Compliance of the regulation requires the correct installation of the product, the observance of specific installation guides and product documentation. This was tested on specific system configurations.

The safety instructions of the manuals are to be considered.

The product must be mounted and used in strict accordance with the installation instructions contained within the installation guide, a copy of which may be obtained from NTI AG.

Company: NTI AG
Spreitenbach, 23.02.2023



Dr.-Ing. Ronald Rohner
CEO NTI AG

ALL LINEAR MOTION FROM A SINGLE SOURCE

Europe / Asia Headquarters

NTI AG - LinMot & MagSpring

Bodenaeckerstrasse 2
CH-8957 Spreitenbach
Switzerland

Sales / Administration: +41 56 419 91 91
office@linmot.com

Tech. Support: +41 56 544 71 00
support@linmot.com

Web: <https://www.linmot.com/>

Visit <https://linmot.com/contact/> to find a distributor near you.

North / South America Headquarters

LinMot USA Inc.

N1922 State Road 120, Unit 1
Lake Geneva, WI 53147
USA

Sales / Administration: 262.743.2555
usasales@linmot.com

Tech. Support: 262.743.2555
usasupport@linmot.com

Web: <https://www.linmot-usa.com/>