

BFW Nut Series

Conventional style, without “anti-backlash” function. The BFW Series general purpose “free-wheeling” nut is for applications not requiring anti-backlash and wear compensation. It provides effective power transmission at minimum cost, and features long life, self-lubricating polyacetal nuts.

The secure mounting and convenience of a circular flange is standard on the BFW nuts with triangular flange and thread mounting as an option. Many custom configurations are available.

Screws are 303 stainless steel with extended life, custom Kerkote® TFE coating optional. Assemblies can be supplied cut-to-length or with ends machined to customer requirements and Kerkote® TFE screw coating are optional.

BFW Series Nut Assemblies



BFW Micro Series Nut Assemblies

BFW Micro Nut Series

The BFW Micro Series enables a whole new range of micro-sized designs. It allows the miniaturization without sacrificing performance or reliability.

Backlash

N/A, Typical Backlash
.003 to .010 (.076 to .25)

Grease Compatibility

Coatings	Compatible
Kerkote® TFE Coating	YES
Black Ice® TFE Coating	YES
Grease	NO

Technical Data

Material	Polyacetal, Lubricant Additive
Tensile Strength	9,700 psi
Coefficient of Expansion	6.0 x 10 ⁻⁵ in/in/°F
Coefficient of Friction Polyacetal Nut to Screw	Static = .08 .08 ** Dynamic = .15 .09 **
Standard Operating Temperature Range	32 - 200° F* (0 - 93° C)*

* Very high or low temperatures may cause significant changes in the nut fit or drag torque. Please call the HKP Engineering Team at 603 213 6290 for optional temperature range materials.

** with Kerkote® TFE Coating.

Identifying the BFW Series Nut Part Number Codes when Ordering

BFW	A	K	R	018	0020	XXXX
Prefix	Nut Mounting Style	Lubrication	Thread Direction	Diameter Code	Nominal Thread Lead Code	Unique Identifier
BFW	A = Flanged (Triangular) F = Flanged (Round) T = Threaded X = Custom For Mini and Micro Series Only: B = Barrel m μ R = Rectangular m μ ^m BFW Mini Series ^μ BFW Micro Series	S = Uncoated K = Kerkote® TFE Coating G = Grease N = Nut only B = Black Ice® TFE Coating	R = Right hand L = Left hand (Not Available for Micro Series) (Refer to leadscrew charts for availability)	008 ^m = .078 in (2 mm) 012 ^m = .125 in (3.2 mm) 013 ^m = .133 in (3.3 mm) 014 ^m = .141 in (3.6 mm) 016 ^m = .156 in (4 mm) 018 ^m = .188 in (5 mm) 021 ^m = .219 in (5.6 mm) 025 = .250 in (6 mm) 031 = .313 in (8 mm) 037 = .375 in (10 mm) 043 = .438 in (11 mm) 050 = .500 in (13 mm) 062 = .625 in (16 mm) 075 = .750 in (19 mm) 087 = .875 in (22 mm) 093 = .938 in (24 mm) ^m BFW Mini Series ^μ BFW Micro Series	(Refer to LEAD CODE Specifications charts, pages 5 to 9)	Proprietary suffix assigned to a specific customer application. The identifier can apply to either a standard or custom part.

NOTE: Dashes must be included in Part Number (-) as shown above. For assistance call our Engineering Team at 603 213 6290.

■ Dimensional Drawings

BFW Round Flange Mount

	Screw Diam.	Nut Diam.	Nut Length	Flange Diam.	Flange Thickness	Mounting Hole Diam.	Bolt Circle Diam.	Dynamic Load
	A inch (mm)	B inch (mm)	C inch (mm)	D inch (mm)	E inch (mm)	F inch (mm)	G inch (mm)	lbs (Kg)
BFWF Flange Mount	1/4 (6)	.50 (12.7)	1.0 (25.4)	100 (25.4)	.19 (4.8)	.140 (3.56)	.750 (19.05)	50 (20)
	5/16 (8)	.63 (15.9)	1.0 (25.4)	1.13 (28.7)	.19 (4.8)	.140 (3.56)	.875 (22.23)	75 (35)
	3/8 (10)	.63 (15.9)	1.0 (25.4)	1.13 (28.7)	.19 (4.8)	.140 (3.56)	.875 (22.23)	75 (35)
	7/16 (11)	.75 (19.1)	1.5 (38)	1.50 (38.1)	.19 (4.8)	.203 (5.16)	1.125 (28.58)	90 (40)
	1/2 (13)	.75 (19.1)	1.5 (38)	1.50 (38.1)	.19 (4.8)	.203 (5.16)	1.125 (28.58)	150 (68)
	5/8 (16)	.88 (22.2)	1.5 (38)	1.50 (38.1)	.19 (4.8)	.203 (5.16)	1.188 (30.18)	225 (100)
	3/4 (19)	1.12 (28.4)	2.0 (51)	1.75 (44.4)	.25 (6.4)	.203 (5.16)	1.438 (36.53)	350 (160)
	7/8 (22)	1.50 (38.1)	2.0 (51)	2.25 (57.1)	.25 (6.4)	.203 (5.16)	1.875 (47.63)	500 (227)
	15/16 (24)	1.50 (38.1)	2.0 (51)	2.25 (57.1)	.25 (6.4)	.203 (5.16)	1.875 (47.63)	500 (227)

Metric numbers are for reference only.

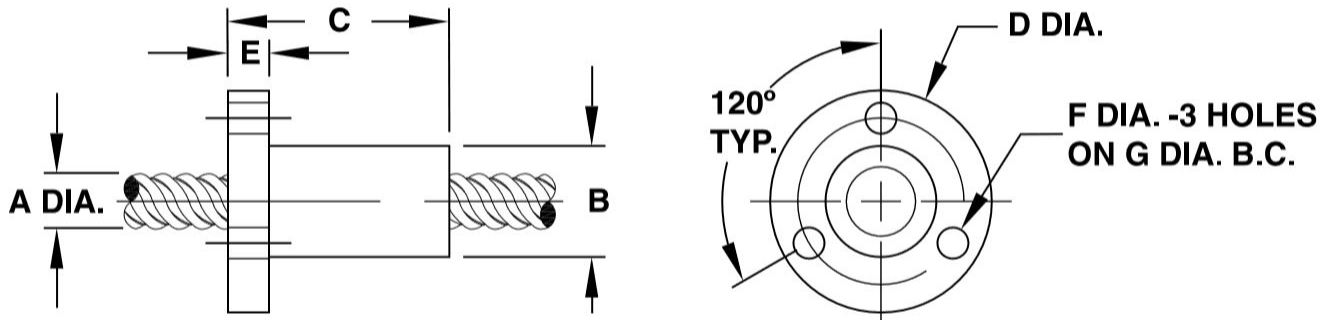

BFW Triangular Flange Mount

	Screw Diam.	Nut Diam.	Nut Length	Flange Diam.	Flange Thickness	Mounting Hole Diam.	Bolt Circle Diam.	Dynamic Load**
	A inch (mm)	B inch (mm)	C inch (mm)	D inch (mm)	E inch (mm)	F inch (mm)	G inch (mm)	lbs (Kg)
BFWA Triangular Flange Mount	1/4 (6)	.50 (12.7)	1.0 (25.4)	1.00 (25.4)	.17 (4.3)	.143 (3.63)	.750 (19.05)	50 (20)
	5/16 (8)	.50 (12.7)	1.9 (48.3)	1.50 (38.1)	.17 (4.3)	.197 (5.00)	1.125 (28.58)	75 (35)
	3/8 (10)	.66 (16.6)	1.9 (48.3)	1.50 (38.1)	.17 (4.3)	.197 (5.00)	1.125 (28.58)	75 (35)
	7/16 (11)	.75 (19.1)	1.9 (48.3)	1.50 (38.1)	.17 (4.3)	.197 (5.00)	1.125 (28.58)	90 (40)
	1/2 (13)	.75 (19.1)	1.9 (48.3)	1.50 (38.1)	.17 (4.3)	.197 (5.00)	1.125 (28.58)	150 (68)

Metric numbers are for reference only.

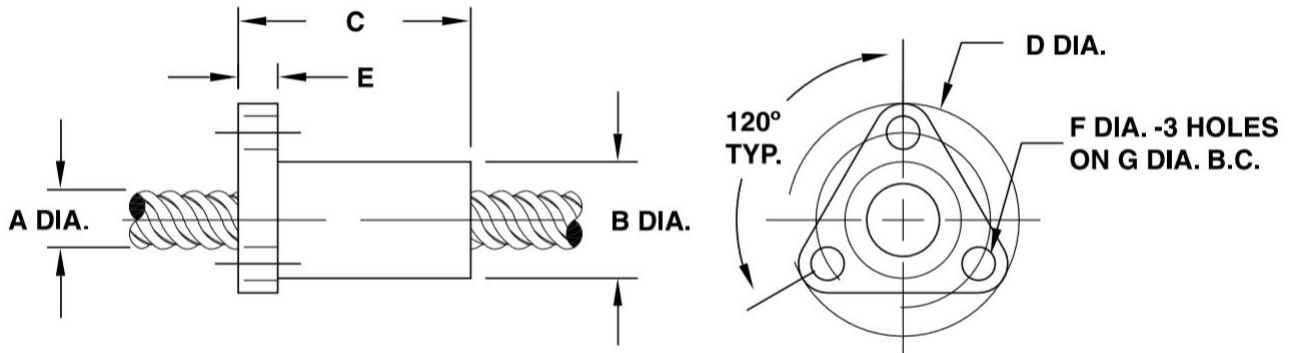

BFW Thread Mount

BFWT Thread Mount	Screw Diam. A	Nut Diam. B	Nut Length C	Thread M*	Thread Length N	Dynamic Load**
	inch (mm)	inch (mm)	inch (mm)	inch	inch (mm)	lbs (Kg)
	1/4 (6)	.63 (15.9)	1.0 (25.4)	9/16 - 18	.187 (4.75)	50 (20)
	5/16 (8)	.75 (19.1)	1.0 (25.4)	5/8 - 18	.250 (6.35)	75 (35)
	3/8 (10)	.75 (19.1)	1.0 (25.4)	5/8 - 18	.250 (6.35)	75 (35)
	7/16 (11)	1.00 (25.4)	1.5 (38.1)	15/16 - 16	.375 (9.53)	90 (40)
	1/2 (13)	1.00 (25.4)	1.5 (38.1)	15/16 - 16	.375 (9.53)	150 (68)
	5/8 (16)	1.00 (25.4)	1.5 (38.1)	15/16 - 16	.375 (9.53)	225 (100)
	3/4 (19)	1.50 (38.1)	2.0 (51)	1 3/8 - 16	.500 (12.70)	350 (160)
	7/8 (22)	1.50 (38.1)	2.0 (51)	1 3/8 - 16	.500 (12.70)	500 (227)
	15/16 (24)	1.50 (38.1)	2.0 (51)	1 3/8 - 16	.500 (12.70)	500 (227)

Metric numbers are for reference only.

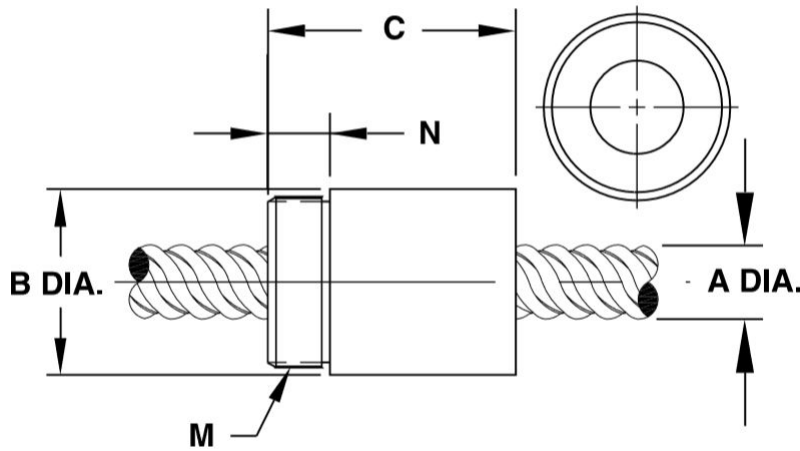

BFWR Mini Rectangular Flange Mount

BFWR Rectangular Flange Mount	Screw Diam. A	Nut Diam. B	Nut Length C	Flange Height D1	Flange Diam. D	Flange Thickness E	Mounting Hole Diam. F	Bolt Circle Diam. G	Dynamic Load	Drag Torque
	inch (mm)	inch (mm)	inch (mm)	inch (mm)	inch (mm)	inch (mm)	inch (mm)	inch (mm)	lbs (Kg)	oz-in (N-m)
	1/8 inch through 7/32 inch (3 mm through 5.6 mm)	0.40 (10.2)	0.50 (13)	0.40 (10.2)	0.75 (19.1)	0.13 (3.2)	0.120 (3.05)	0.600 (15.24)	25 (11)	Free Wheeling

Metric numbers are for reference only.

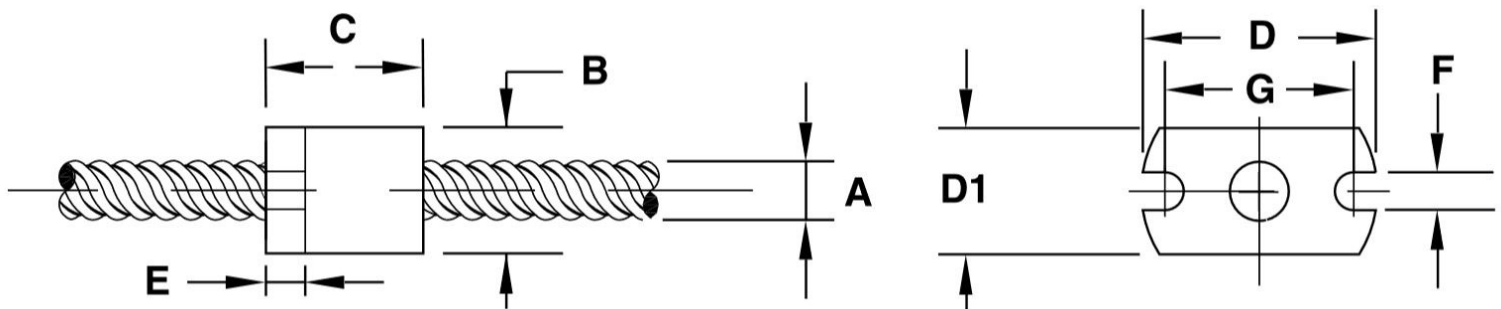

BFW Mini Thread Mount

BFWT Thread Mount	Screw Diam. A	Nut Diam. B	Nut Length C	Thread M*	Thread Length N	Dynamic Load	Drag Torque
	inch (mm)	inch (mm)	inch (mm)	inch	inch (mm)	lbs (Kg)	oz-in (N-m)
	1/8 inch through 7/32 inch (3 mm through 5.6 mm)	0.40 (10.2)	0.50 (13)	3/8-24	0.187 (4.75)	25 (11)	Free Wheeling

Metric numbers are for reference only.

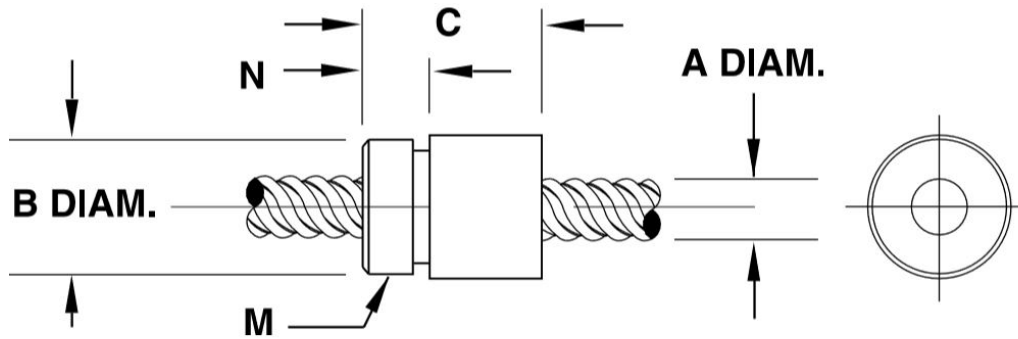

BFW Micro Barrel Mount

BFWB Barrel Mount	Screw Diam. A	Nut Diam. B	Nut Length C	Nut Flats D	Dynamic Load	Drag Torque
	inch (mm)	inch (mm)	inch (mm)	inch (mm)	lbs (Kg)	oz-in (N-m)
	5/64 (2)	0.22 (5.5)	0.32 (8)	0.20 (5.08)	10 (4.5)	Free Wheeling

Metric numbers are for reference only.

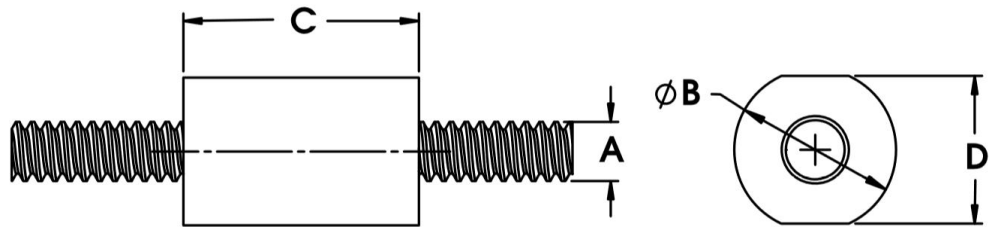

BFW Micro Rectangular Flange Mount

BFWR Rectangular Flange Mount	Screw Diam. A	Nut Diam. B	Nut Length C	Flange Height D1	Flange Diam. D	Flange Thickness E	Mounting Hole Diam. F	Bolt Circle Diam. G	Dynamic Load	Drag Torque
	inch (mm)	inch (mm)	inch (mm)	inch (mm)	inch (mm)	inch (mm)	inch (mm)	inch (mm)	lbs (Kg)	oz-in (N-m)
	5/64 (2)	0.22 (5.5)	0.32 (8)	0.22 (5.5)	0.47 (11.9)	0.08 (2.0)	0.07 (1.8)	0.35 (9.0)	10 (4.5)	Free Wheeling

Metric numbers are for reference only.

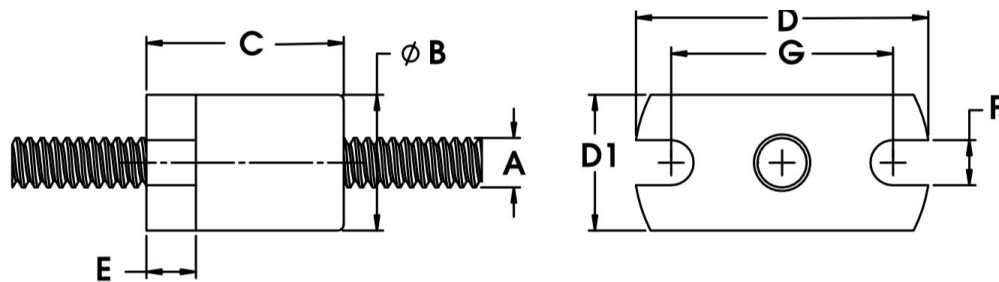

BFW Nut Series - General Purpose Backlash

■ Lead Screw Compatibility: BFW Series

Diameter		Diameter Code	Lead		LEAD CODE	Left Hand Available	Outside Diameter (for reference)		Root Diameter (for reference)		Efficiency %*
inches	mm		inches	mm			inches	mm	inches	mm	
5/64	2	008	0.012	0.30	0012		0.079	2.01	0.068	1.73	24**
			0.016	0.40	0016		0.075	1.91	0.058	1.47	30**
			0.020	0.50	0020		0.077	1.96	0.057	1.45	36**
			0.039	1.00	0039		0.079	2.01	0.059	1.50	52**
			0.079	2.00	0079		0.077	1.96	0.057	1.45	66**
1/8	3.2	012	0.024	0.61	0024		0.129	3.28	0.093	2.36	44
			0.039	1.00	0039		0.129	3.28	0.094	2.39	57
			0.048	1.22	0048		0.129	3.28	0.093	2.36	61
			0.075	1.91	0075		0.129	3.28	0.093	2.36	70
			0.096	2.44	0096	•	0.129	3.28	0.093	2.36	75
			0.125	3.18	0125	LH Only	0.125	3.18	0.078	1.98	80
.132	3.3	013	0.020	0.50	0020		0.132	3.35	0.104	2.64	42
			0.039	1.00	0039		0.132	3.35	0.080	2.03	61
			0.079	2.00	0079		0.132	3.35	0.080	2.03	75
			0.157	4.00	0157		0.132	3.35	0.080	2.03	84
			0.315	8.00	0315		0.132	3.35	0.080	2.03	87
9/64	3.6	014	0.012	0.30	0012		0.140	3.56	0.123	3.12	26
			0.024	0.61	0024		0.140	3.56	0.105	2.67	43
			0.048	1.22	0048		0.140	3.56	0.081	2.06	62
			0.096	2.44	0096		0.140	3.56	0.081	2.06	75
			0.394	10.00	0394		0.140	3.56	0.102	2.59	86
5/32	4	016	0.033	0.84	0033	•	0.156	3.96	0.116	2.95	45
			0.050	1.27	0050	LH Only	0.156	3.96	0.096	2.44	59
			0.094	2.39	0094		0.164	4.17	0.128	3.25	67
			0.125	3.18	0125		0.168	4.27	0.130	3.30	74
			0.250	6.35	0250		0.156	3.96	0.130	3.30	83
			0.375	9.53	0375		0.156	3.96	0.130	3.30	85
			0.500	12.70	0500		0.156	3.96	0.130	3.30	86
3/16	5	018	0.020	0.50	0020		0.188	4.78	0.163	4.14	30
			0.025	0.64	0025		0.188	4.78	0.150	3.81	39
			0.039	1.00	0039		0.188	4.78	0.144	3.66	47
			0.050	1.27	0050		0.188	4.78	0.124	3.15	58
			0.100	2.54	0100		0.188	4.78	0.136	3.45	69
			0.1875	4.76	0188		0.188	4.78	0.167	4.24	78
			0.200	5.08	0200		0.188	4.78	0.124	3.15	82
			0.375	9.53	0375		0.188	4.78	0.161	4.09	84
			0.400	10.16	0400		0.188	4.78	0.124	3.15	84
			0.427	10.85	0427		0.188	4.78	0.162	4.11	85
			0.500	12.70	0500	•	0.188	4.78	0.142	3.61	86

Shaded areas have been translated from their designed inch or mm dimension to an equivalent mm or inch dimension.

* Listed efficiencies are theoretical values based on Kerkote® TFE coated lead-screw

** Listed efficiencies for Micro screws are theoretical values based on non-coated lead-screws

BFW Nut Series - General Purpose Backlash

Lead Screw Compatibility: BFW Series

Diameter		Diameter Code	Lead		LEAD CODE	Left Hand Available	Outside Diameter (for reference)		Root Diameter (for reference)		Efficiency %*
inches	mm		inches	mm			inches	mm	inches	mm	
7/32	5.6	021	0.024	0.61	0024		0.218	5.54	0.181	4.60	31
			0.03125	0.79	0031		0.204	5.18	0.160	4.06	39
			0.048	1.22	0048		0.216	5.49	0.156	3.96	50
			0.050	1.27	0050		0.200	5.08	0.135	3.43	52
			0.0625	1.59	0063		0.218	5.54	0.142	3.61	60
			0.096	2.44	0096		0.218	5.54	0.156	3.96	66
			0.192	4.88	0192		0.218	5.54	0.156	3.96	78
			0.250	6.35	0250	•	0.204	5.18	0.140	3.56	81
			0.384	9.75	0384		0.218	5.54	0.159	4.04	86
1/4	6	025	0.024	0.61	0024		0.250	6.35	0.218	5.54	28
			0.025	0.64	0025		0.250	6.35	0.214	5.44	30
			0.03125	0.79	0031		0.250	6.35	0.208	5.28	34
			0.039	1.00	0039		0.250	6.35	0.190	4.83	40
			0.048	1.22	0048		0.250	6.35	0.190	4.83	45
			0.050	1.27	0050	•	0.250	6.35	0.191	4.85	46
			0.059	1.50	0059		0.250	6.35	0.172	4.37	52
			0.0625	1.59	0063		0.250	6.35	0.170	4.32	52
			0.079	2.00	0079		0.250	6.35	0.170	4.32	59
			0.096	2.44	0096		0.250	6.35	0.190	4.83	61
			0.100	2.54	0100		0.250	6.35	0.190	4.83	62
			0.118	3.00	0118		0.250	6.35	0.175	4.45	68
			0.125	3.18	0125		0.250	6.35	0.190	4.83	67
			0.197	5.00	0197		0.250	6.35	0.172	4.37	72
			0.200	5.08	0200		0.250	6.35	0.170	4.32	65
			0.250	6.35	0250	•	0.250	6.35	0.168	4.27	79
			0.3125	7.94	0313		0.250	6.35	0.184	4.67	81
			0.333	8.46	0333		0.250	6.35	0.170	4.32	82
			0.394	10.00	0394		0.250	6.35	0.170	4.32	78
			0.400	10.16	0400		0.250	6.35	0.170	4.32	84
0.500	12.70	0500	•	0.250	6.35	0.169	4.29	85			
0.750	19.05	0750		0.250	6.35	0.170	4.32	86			
1.000	25.40	1000	•	0.250	6.35	0.170	4.32	84			
5/16	8	031	0.039	1.00	0039		0.315	8.00	0.261	6.63	34
			0.057	1.44	0057		0.315	8.00	0.243	6.17	43
			0.0741	1.88	0074		0.312	7.92	0.211	5.36	51
			0.111	2.82	0111		0.312	7.92	0.232	5.89	60
			0.167	4.24	0167		0.312	7.92	0.211	5.36	69
			0.250	6.35	0250		0.312	7.92	0.234	5.94	76
			0.500	12.70	0500		0.312	7.92	0.232	5.89	83
			0.800	20.32	0800		0.306	7.77	0.243	6.17	86

Shaded areas have been translated from their designed inch or mm dimension to an equivalent mm or inch dimension.

* Listed efficiencies are theoretical values based on Kerkote® TFE coated lead-screw
 ** Listed efficiencies for Micro screws are theoretical values based on non-coated lead-screws

BFW Nut Series - General Purpose Backlash

■ Lead Screw Compatibility: BFW Series

Diameter		Diameter Code	Lead		LEAD CODE	Left Hand Available	Outside Diameter (for reference)		Root Diameter (for reference)		Efficiency %*
inches	mm		inches	mm			inches	mm	inches	mm	
3/8	10	037	0.025	0.64	0025		0.375	9.53	0.337	8.56	21
			0.039	1.00	0039		0.394	10.01	0.350	8.89	28
			0.04167	1.06	0042		0.375	9.53	0.320	8.13	34
			0.050	1.27	0050	•	0.375	9.53	0.301	7.65	36
			0.055	1.40	0055		0.375	9.53	0.303	7.70	38
			0.059	1.50	0059	•	0.389	9.88	0.313	7.95	38
			0.0625	1.59	0063	•	0.388	9.86	0.295	7.49	41
			0.068	1.73	0068		0.388	9.86	0.295	7.49	42
			0.079	2.00	0079		0.375	9.53	0.264	6.71	47
			0.0833	2.12	0083		0.375	9.53	0.293	7.44	48
			0.100	2.54	0100	•	0.375	9.53	0.266	6.76	53
			0.125	3.18	0125	•	0.375	9.53	0.295	7.49	59
			0.157	4.00	0157		0.375	9.53	0.274	6.96	65
			0.1667	4.23	0167		0.371	9.42	0.261	6.63	61
			0.197	5.00	0197		0.375	9.53	0.266	6.76	69
			0.200	5.08	0200	•	0.375	9.53	0.266	6.76	69
			0.250	6.35	0250		0.375	9.53	0.268	6.81	70
			0.300	7.62	0300		0.375	9.53	0.255	6.48	76
			0.333	8.46	0333		0.375	9.53	0.245	6.22	78
			0.363	9.22	0363	•	0.375	9.53	0.260	6.60	79
			0.375	9.53	0375		0.375	9.53	0.265	6.73	79
			0.394	10.00	0394		0.375	9.53	0.260	6.60	79
			0.400	10.16	0400		0.375	9.53	0.293	7.44	79
			0.472	12.00	0472		0.388	9.86	0.287	7.29	82
			0.500	12.70	0500	•	0.388	9.86	0.265	6.73	81
			0.667	16.94	0667		0.375	9.53	0.273	6.93	83
			0.667	19.05	0750		0.388	9.86	0.273	6.93	84
			0.984	25.00	0984		0.375	9.53	0.262	6.65	84
			1.000	25.40	1000		0.383	9.73	0.254	6.45	84
			1.200	30.48	1200	•	0.383	9.73	0.254	6.45	84
1.250	31.75	1250		0.375	9.53	0.278	7.06	84			
1.500	38.10	1500		0.375	9.53	0.264	6.71	83			
7/16	11	043	0.050	1.27	0050		0.437	11.10	0.362	9.19	30
			0.0625	1.59	0063	•	0.436	11.07	0.358	9.09	38
			0.079	2.00	0079		0.472	11.99	0.374	9.50	42
			0.111	2.82	0111		0.437	11.10	0.327	8.31	52
			0.118	3.00	0118		0.438	11.13	0.363	9.22	52
			0.125	3.18	0125		0.438	11.13	0.357	9.07	54
			0.197	5.00	0197		0.438	11.13	0.315	8.00	65
			0.236	6.00	0236		0.433	11.00	0.313	7.95	70
			0.250	6.35	0250		0.442	11.23	0.325	8.26	70
			0.307	7.80	0307		0.445	11.30	0.343	8.71	73
			0.325	8.26	0325		0.444	11.28	0.342	8.69	74
			0.394	10.00	0394		0.446	11.33	0.331	8.41	78
			0.472	12.00	0472		0.438	11.13	0.318	8.08	80
			0.500	12.70	0500		0.452	11.48	0.327	8.31	80
			0.615	15.62	0615		0.475	12.07	0.376	9.55	82

Shaded areas have been translated from their designed inch or mm dimension to an equivalent mm or inch dimension.

* Listed efficiencies are theoretical values based on Kerkote® TFE coated lead-screw

** Listed efficiencies for Micro screws are theoretical values based on non-coated lead-screws

Lead Screw Compatibility: BFW Series

Diameter		Diameter Code	Lead		LEAD CODE	Left Hand Available	Outside Diameter (for reference)		Root Diameter (for reference)		Efficiency %*
inches	mm		inches	mm			inches	mm	inches	mm	
1/2	13	050	0.050	1.27	0050		0.495	12.57	0.433	11.00	29
			0.079	2.00	0079		0.473	12.01	0.355	9.02	41
			0.098	2.50	0098		0.500	12.70	0.383	9.73	46
			0.100	2.54	0100	•	0.490	12.45	0.364	9.25	46
			0.125	3.18	0125		0.500	12.70	0.374	9.50	51
			0.157	4.00	0157		0.500	12.70	0.384	9.75	58
			0.160	4.06	0160		0.500	12.70	0.388	9.86	67
			0.1667	4.23	0167		0.500	12.70	0.384	9.75	58
			0.197	5.00	0197		0.500	12.70	0.365	9.27	62
			0.200	5.08	0200	•	0.492	12.50	0.366	9.30	63
			0.250	6.35	0250		0.500	12.70	0.382	9.70	67
			0.333	8.46	0333	•	0.497	12.62	0.362	9.19	73
			0.394	10.00	0394		0.497	12.62	0.362	9.19	76
			0.400	10.16	0400		0.497	12.62	0.364	9.25	76
			0.500	12.70	0500		0.488	12.40	0.352	8.94	79
			0.630	16.00	0630		0.500	12.70	0.374	9.50	80
			0.750	19.05	0750		0.525	13.34	0.399	10.13	83
			0.800	20.32	0800		0.500	12.70	0.370	9.40	83
			0.984	25.00	0984		0.500	12.70	0.369	9.37	84
1.000	25.40	1000	•	0.490	12.45	0.372	9.45	84			
1.500	38.10	1500		0.490	12.45	0.374	9.50	85			
2.000	50.80	2000		0.488	12.40	0.378	9.60	87			
5/8	16	062	0.100	2.54	0100		0.615	15.62	0.498	12.65	40
			0.125	3.18	0125	•	0.625	15.88	0.470	11.94	45
			0.200	5.08	0200		0.625	15.88	0.495	12.57	53
			0.250	6.35	0250		0.625	15.88	0.469	11.91	63
			0.315	8.00	0315		0.627	15.93	0.493	12.52	68
			0.410	10.41	0410	•	0.625	15.88	0.481	12.22	72
			0.500	12.70	0500	•	0.625	15.88	0.478	12.14	76
			0.630	16.00	0630		0.625	15.88	0.491	12.47	78
			1.000	25.40	1000		0.625	15.88	0.481	12.22	83
			1.500	38.10	1500		0.625	15.88	0.499	12.67	85
			1.575	40.00	1575	•	0.625	15.88	0.499	12.67	86
			2.000	50.80	2000	•	0.625	15.88	0.499	12.67	86

Shaded areas have been translated from their designed inch or mm dimension to an equivalent mm or inch dimension.

* Listed efficiencies are theoretical values based on Kerkote® TFE coated lead-screw
 ** Listed efficiencies for Micro screws are theoretical values based on non-coated lead-screws

BFW Nut Series - General Purpose Backlash

Lead Screw Compatibility: BFW Series

Diameter		Diameter Code	Lead		LEAD CODE	Left Hand Available	Outside Diameter (for reference)		Root Diameter (for reference)		Efficiency %*
inches	mm		inches	mm			inches	mm	inches	mm	
3/4	19	075	0.0625	1.59	0063		0.750	19.05	0.671	17.04	25
			0.098	2.50	0098		0.742	18.85	0.626	15.90	35
			0.100	2.54	0100	•	0.746	18.95	0.624	15.85	35
			0.1667	4.23	0167		0.727	18.47	0.645	16.38	47
			0.197	5.00	0197		0.745	18.92	0.624	15.85	51
			0.200	5.08	0200		0.741	18.82	0.632	16.05	52
			0.250	6.35	0250		0.731	18.57	0.639	16.23	57
			0.276	7.00	0276		0.750	19.05	0.624	15.85	59
			0.333	8.46	0333		0.750	19.05	0.624	15.85	64
			0.394	10.00	0394		0.745	18.92	0.619	15.72	67
			0.500	12.70	0500		0.744	18.90	0.624	15.85	73
			0.551	14.00	0551		0.750	19.05	0.624	15.85	73
			0.591	15.00	0591		0.749	19.02	0.623	15.82	74
			0.709	18.00	0709		0.780	19.81	0.650	16.51	77
			0.748	19.00	0748		0.672	17.07	0.547	13.89	80
			0.787	20.00	0787		0.780	19.81	0.648	16.46	78
			0.800	20.32	0800		0.750	19.05	0.618	15.70	79
			0.945	24.00	0945	•	0.734	18.64	0.633	16.08	80
			1.000	25.40	1000	•	0.743	18.87	0.619	15.72	81
			1.500	38.10	1500		0.712	18.08	0.590	14.99	84
1.969	50.00	1969	•	0.751	19.08	0.620	15.75	84			
2.000	50.80	2000	•	0.742	18.85	0.611	15.52	84			
2.400	60.96	2400	•	0.750	19.05	0.620	15.75	84			
3.622	92.00	3622	•	0.750	19.05	0.634	16.10	87			
7/8	22	087	0.200	5.08	0200	•	0.870	22.10	0.742	18.85	48
			0.236	6.00	0236		0.848	21.54	0.773	19.63	52
			0.250	6.35	0250		0.875	22.23	0.749	19.02	53
			0.394	10.00	0394		0.875	22.23	0.741	18.82	65
			0.500	12.70	0500		0.862	21.89	0.744	18.90	69
			0.630	16.00	0630		0.875	22.23	0.741	18.82	73
			0.667	16.94	0667		0.871	22.12	0.745	18.92	74
			0.787	20.00	0787		0.875	22.23	0.741	18.82	78
			0.945	24.00	0945		0.875	22.23	0.741	18.82	79
			1.000	25.40	1000		0.871	22.12	0.742	18.85	80
15/16	24	093	0.050	1.27	0050	LH Only	0.938	23.83	0.874	22.20	17
			2.000	50.80	2000		0.927	23.55	0.815	20.70	85
			3.000	76.20	3000	•	0.939	23.85	0.803	20.40	86

Shaded areas have been translated from their designed inch or mm dimension to an equivalent mm or inch dimension.

* Listed efficiencies are theoretical values based on Kerkote® TFE coated lead-screw

** Listed efficiencies for Micro screws are theoretical values based on non-coated lead-screws

■ Material & Teflon TFE Coating Options

Materials		Teflon TFE Coatings	
Kerkite® Composite Polymer Nuts	<p>In addition to the Kerk® self-lubricating acetal nut material, we offer a variety of custom compounded Kerkite composite polymers. Kerkite polymers are a family of high performance materials that offer exceptional wear properties with the cost and design advantages afforded through injection molding. Kerkite polymers offer a variety of mechanical, thermal and electrical properties and are compatible with many chemicals and environmental conditions. Each member of the Kerkite family is compounded with lubricants, reinforcements and thermoplastic polymers formulated to provide optimum performance in its target conditions and applications.</p>	Kerkote® TFE Coating	<p>Soft coating that is a long-term, maintenance-free, dry lubricant, optimized for softer plastics like acetals and nylons, with or without mechanical reinforcement. Lubrication to the nut/screw interface occurs by the nut picking up Kerkote® TFE particles from the coating as well as from the migration of the internal lubricant within the plastic nut. The transfer of TFE to the nut continues throughout the operating life of the assembly as long as the nut periodically travels over areas with Kerkote® TFE coating. The lubricant, although solid, also has some "spreading" ability as in fluid lubricants. Kerkote® TFE coated screws provide the maximum level of self-lubrication and should not be additionally lubricated or used in environments where oils or other lubricant contamination is possible.</p>
Special Materials	<p>Kerk® has rolled screws in many materials, including 316 stainless, 400 series stainless, precipitate hardening materials, carbon steel, aluminum, and titanium. Kerk® nuts have been produced in many alternative plastics including PEEK, polyester, Torlon®, Vespel®, PVDF, UHMW, Ertalyte®, customer-supplied specialty materials, and metal nuts made from bronze, brass, and stainless steel. If the material can be molded, machined, ground, or rolled, we can likely process it.</p>	Black Ice® TFE Coating	<p>Hard coating that is long term, maintenance-free and is exceptionally durable in all types of environments, with virtually any type of polymer nut. Black Ice® TFE coating remains on the screw, offering a low friction surface upon which the nut travels. Rather than acting as a dry lubricant, Black Ice® TFE is an anti-friction coating whose surface properties displace the metal to which it is applied. Though it is not intended for use with metal or glass fiber reinforced nuts, Black Ice® TFE is bonded securely to the screw's surface and can withstand abrasion from contamination, rigid polymer systems, fluid impingement and wash down applications. Black Ice® TFE can be used in more aggressive environment conditions, or anywhere reduced friction and a permanent coating is desired. Not intended to be used with additional lubricants.</p>

Note: There are certain applications where external lubrication may be desired. These include the use of nut materials such as glass reinforced plastic or metal. Greases, when used properly can provide unique capabilities and Haydon Kerk Motion Solutions does offer a selection of greases developed specifically for these applications. Please contact a sales engineer for assistance selecting the best lubricant for your requirements.