



A single unit that axially moves a component to an insertion position and then rotates it

In certain applications, it is required to have both rotary and linear motion. Such an application, for example, is in the robotic picking and placing of components where it may be required to axially move a component to an insertion position and then rotate the component to screw it in place. Another type of application requiring a shaft, which may selectively rotate and/or reciprocate, is in the precise control of laparoscopic and other such medical instruments.

In either type of application, it is frequently required that the linear motion be locked while rotary motion takes place. Conventional motor arrangements are often complicated and heavy, a substantial disadvantage for robotics applications. A problem with motors having linear motion is that the motors frequently provide inadequate output shaft support when heavy side loads are imposed on the output shafts.

The Haydon™ line of dual motion actuators provides independent linear and rotary motion from a compact package. The actuators are based on unique, patented designs and incorporate proven motor technology. These units simplify product development by replacing what would otherwise be far more bulky and complex mechanisms. Another feature of this design is to provide an electric motor in which linear and rotary motions are controllable independently of one another.

A limitless number of operating parameters are offered allowing each device to be custom manufactured according to customer specific application requirements. For a rotary/linear motor, it is desirable that the linear and rotary motions be controllable independently of one another. These devices can be run using a standard two axis stepper motor driver. Performance can be enhanced using chopper and/or microstepping drives.

For linear actuator data for the dual motion actuators please see the 35000 Series (Size 14) and 43000 Series (Size 17) hybrid linear actuators sections of this catalog. The curves for the rotary portion of the motors appear in the pages that follow.

Part Number Construction: Dual Motion Actuators

LR	35	K	H	4	J	05	910
Prefix	Series number designation	Rotary Step Angle	Linear Step Angle	Coils	Code ID Resolution Travel/Step	Voltage	Suffix: Stroke
LR = Linear/Rotary	35 = 35000 Available Series: 35000 43000 (Series numbers represent width ² of motor body)	H = 1.8° K = 0.9° M = 1.8° P = 0.9° Double Stack	H = 1.8° K = 0.9° M = 1.8° P = 0.9° Double Stack	4 = Bipolar (4 wire) 6 = Unipolar (6 wire)	(Example: J = travels .00048-in per step) <i>(Refer to travel /step chart found on each Series product page.)</i>	(Example: 05 = 5 VDC; 12 = 12 VDC) Custom V available	Example: -910 = 1-in (26 mm) -XXX = Special or custom (Special part numbers for custom screw lengths and design options will require an issued 3 digit suffix number. Please contact our sales or applications engineering department for assistance.)

EXAMPLE:

LR35KH4AB-05-910 = Dual motion, 35000 Series (Size 14, 1.5-in, 35 mm sq.), 0.9° rotary, 1.8° linear, bipolar coils, .00048-in (0.0121 mm), 5 Volts DC, 1-in (26 mm) stroke

35000 Series (Size 14) Dual Motion Actuators



HaydonKerk Motion Solutions™ • www.HaydonKerk.com • Phone: 800.243.2715 • International: 203.756.7441

Dimensional Drawings

DUAL MOTION ACTUATOR
LINEAR & ROTARY MOTION

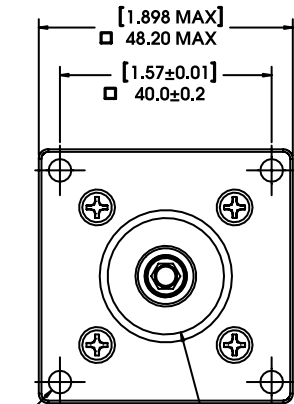

Standard strokes available:
1" (26 mm), 2" (51 mm) and
4" (102 mm). Customized strokes
available to 6" (152 mm)

STROKE	DIM. "A"	SUFFIX	M4x0.7 thread
0.50 (12.7)	3.9 (99.3)	- 905	- 805
1.00 (25.4)	4.409 (112.0)	- 910	- 810
2.00 (50.8)	5.409 (137.4)	- 920	- 820
4.00 (101.6)	7.409 (188.2)	- 940	- 840

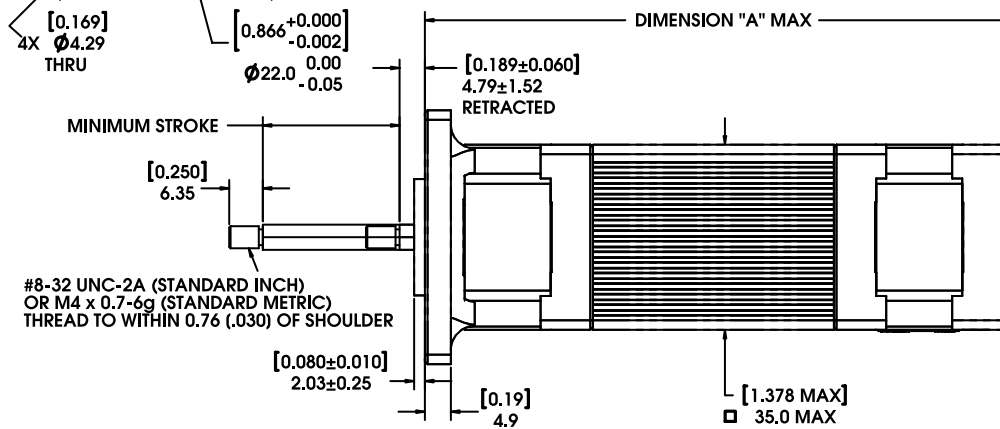

Technical Specification

Linear Travel / Step inches	mm	Order Code I.D.
0.000098*	0.0025	AA
0.00012	0.0030*	N
0.00019*	0.005	AB
0.00024	0.0060*	K
0.00039*	0.01	AC
0.00048	0.0121*	J
0.00078*	0.02	AD
0.00157*	0.04	AE

*Values truncated

Standard motors are Class B rated for maximum temperature of 130°C.

35000 Series Size 14 • Rotary Function • Bipolar • 100% Duty Cycle

Torque curves for 35000 Series Linear Actuators. See FORCE/SPEED curves for 35000 Series Linear Actuator on pages 68 and 69.

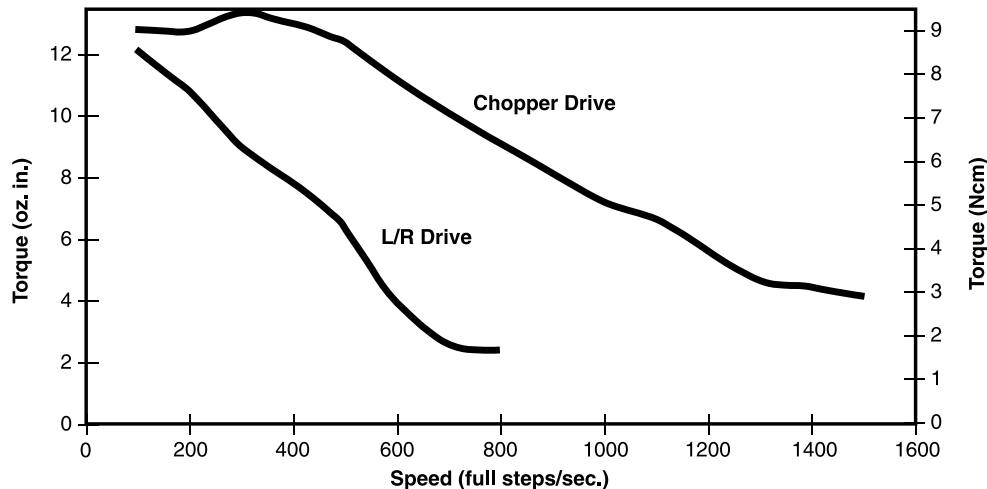

NOTE: All chopper drive curves were created with a 5 volt motor and a 40 volt power supply.

Ramping can increase the performance of a motor either by increasing the top speed or getting a heavier load accelerated up to speed faster. Also, deceleration can be used to stop the motor without overshoot.

With L/R drives peak force and speeds are reduced, using a unipolar drive will yield a further 30% force reduction.

Technical Specification

Linear Travel / Step		Order Code I.D.
inches	mm	
0.000078*	0.00198*	V
0.00012	0.0030*	N
0.000156259	0.0039*	P
0.0003125	0.0079*	A
0.0004167	0.0105*	S
0.00048	0.0121*	J
0.0005	0.0127	3
0.000625	0.0158*	B
0.00078*	0.02	AD
0.0008333	0.0211*	T
0.00096	0.0243*	Q
0.001	0.0245	1
0.00125	0.0317*	C
0.00192	0.0487*	R
0.002	0.0508	2

*Values truncated

Standard motors are Class B rated for maximum temperature of 130°C.

Dimensional Drawings

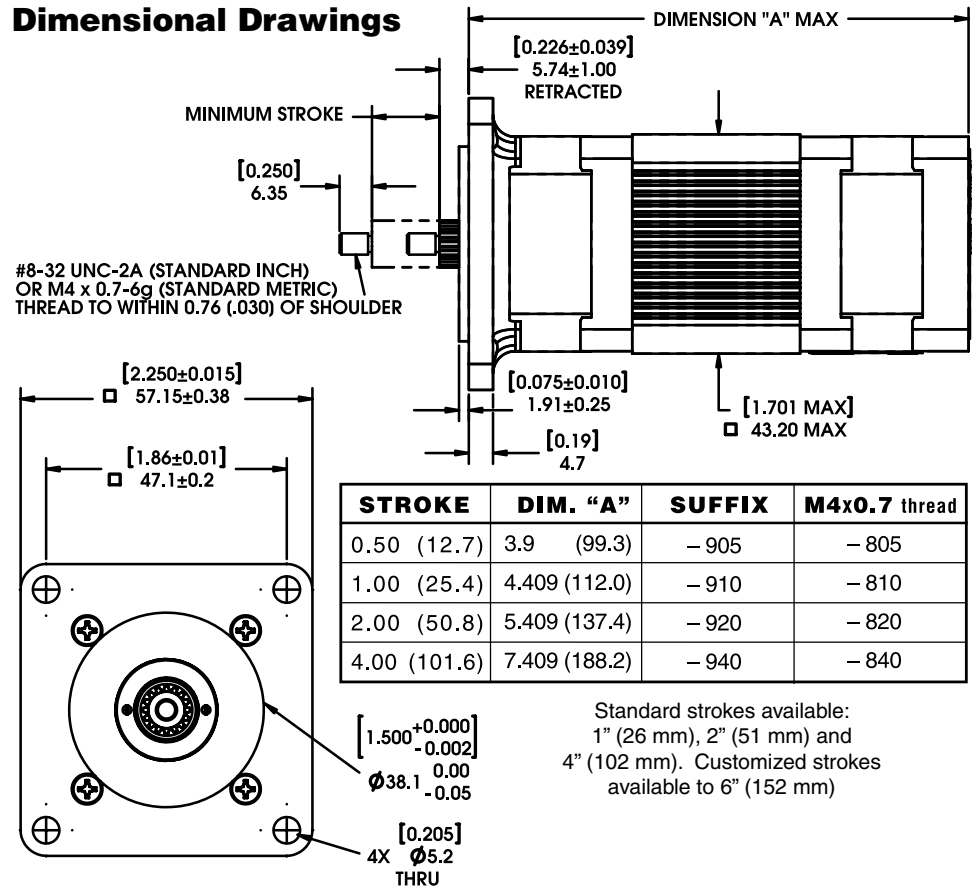

DUAL MOTION ACTUATOR
LINEAR & ROTARY MOTION

43000 Series Size 17 • Rotary Function • Bipolar • 100% Duty Cycle

Torque curves for 43000 Series Linear Actuators. See FORCE/SPEED curves for 43000 Series Linear Actuator on pages 77 and 78.

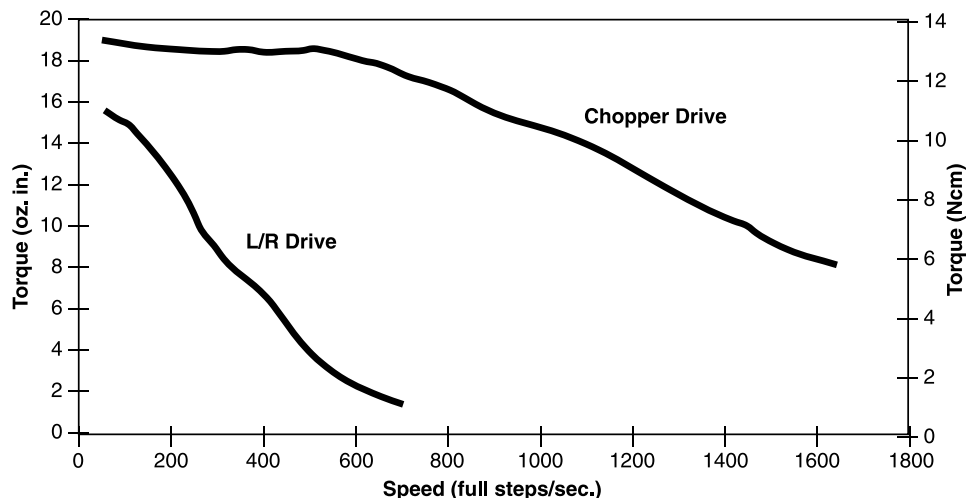

NOTE: All chopper drive curves were created with a 5 volt motor and a 40 volt power supply.

Ramping can increase the performance of a motor either by increasing the top speed or getting a heavier load accelerated up to speed faster. Also, deceleration can be used to stop the motor without overshoot.

With L/R drives peak force and speeds are reduced, using a unipolar drive will yield a further 30% force reduction.